

MITSUBISHI DIESEL ENGINE

S16R

For EPA Certified Engine

OPERATION & MAINTENANCE MANUAL

Issued: December 2021

Pub. No. 290Y1-40220

Revision: 4

CAUTION

- Read this Operation & Maintenance Manual, and conduct the engine operation, inspection and maintenance only after sufficiently understanding the description.
- Please keep this Operation & Maintenance Manual with related manuals at a suitable place for quick reference when needed.



**MITSUBISHI HEAVY INDUSTRIES
ENGINE & TURBOCHARGER**

Contact Us for MHJET Engine Parts

According to the contents of the inquiry, we may share personal information including your name, address, telephone number, e-mail address and contents of the inquiry with our group companies. In this case, MHI take responsibility for managing personal information and will not use such information for purposes other than responding to your inquiry.

<http://www.mhiet.co.jp/en/products/contact/index.html>



Request & Inquiry About Maintenance

According to the contents of the inquiry, we may share personal information including your name, address, telephone number, e-mail address and contents of the inquiry with our group companies. In this case, MHI take responsibility for managing personal information and will not use such information for purposes other than responding to your inquiry.

<http://www.mhiet.co.jp/en/products/engine/service/maintenance/consulting/index.html>



-
- Company names or product names described in this Operation and Maintenance Manual are trademarks or registered trademarks of their respective owners in general.

FOREWORD

This Operation & Maintenance Manual describes information and basic points required to use the Mitsubishi Diesel Engine (hereinafter called the "engine") correctly and effectively.

Please read this manual before using the engine.

In addition, operation, inspection and maintenance of the engine must be limited to the persons who understand the contents of this manual sufficiently.

■ California, U.S.A.- Proposition 65 Warning Statement

 **WARNING:** Breathing diesel engine exhaust exposes you to chemicals known to the State of California to cause cancer and birth defects or other reproductive harm.

- Always start and operate the engine in a well-ventilated area.
- If in an enclosed area, vent the exhaust to the outside.
- Do not modify or tamper with the exhaust system.
- Do not idle the engine except as necessary.

For more information go to www.P65warnings.ca.gov/diesel.

IMPORTANT INFORMATION

Intended Purpose and Use

This engine is a general purpose engine, which is suitable for the following purposes in an industrial power generator:

Continuous use engine:

It can be used as the main engine of a power generator, whose base load is kept constant by, for an example, combination with commercial power supply.

Or, it can be used in a power generator which is used in place of commercial power supply and the load generally fluctuates throughout a day.

Emergency use engine:

It can be used for an emergency power generator which supplies electricity in case of power failure of the main or commercial power supply.

However, its operation is regulated in terms of the annual operating time.

Please check the ["Rating Definition" \(→ Page 120\)](#).

Do not use this engine for other purposes and applications other than those above-mentioned.

General

- This engine must be operated, inspected and maintained only by qualified persons who have thorough knowledge of engines and their dangers, and also have received risk avoidance training.
- Be sure to read and understand this manual before operating, inspecting, and maintaining the engine. Working with insufficient understanding could cause personal injury or damage to the devices due to unexpected operation of them.
- Inadequate operation or maintenance will cause unexpected damage to the device due to accumulated engine damage if not cause immediate failure. Carefully perform engine operation and maintenance.
- Be sure to obey the applicable laws and regulations of the national government and other local municipalities.
- When disposing this engine, follow the method defined by the national government or other local municipalities.
- When discarding fuel, engine oil, or coolant, follow the method defined by the national government or other local municipalities.
- The devices covered by the recycle law and those for which recycling requirements are stipulated shall be disposed in accordance with the corresponding laws and regulations.
- Install an hour meter on the engine so that you can find the exact engine operating time, thereby performing the specified maintenance at the appropriate time in accordance the Scheduled Maintenance as described herein.

Important Tips for Safety of Work

- To avoid a potential risk, you must thoroughly understand the functions of this engine.
- All involved personnel should actively participate, recognize their roles, and organize themselves and their work to ensure a safe environment.
- To prevent injury, fatal accident or damage to this engine, you must observe the cautions, compliance rules and normal directions of use described in this manual while giving the highest priority to safety. If you do not obey:
 - (a) it could result in death in the worst case.
 - (b) it could damage your health.
 - (c) it may cause damage to this engine or the devices.
- Since there are quite a lot of things you cannot do, or you must not do, it is impossible to indicate every caution in this manual or warning labels. As such, it is extremely important to follow instructions in this manual and also to take general safety measures when operating, inspecting, and maintaining the engine.
- WARNING in this manual indicates a risk that cannot be eliminated by design countermeasures or protection equipment evaluated by risk analysis.
- Descriptions about devices and facilities outside the scope of our supply are included in this manual. For the devices and equipment outside the scope of our supply, you must refer to the related manual and the supplier's instruction manual and observe the contents of description.
- Electrical instruments must be inspected or maintained by a person who has received education and training for handling and avoiding risks about the electrical instruments on the machine, in addition to general knowledge needed for electric construction work.

To the User Company

The user company must obey the following points and ensure safety management thoroughly.

General

- When modifying this engine, changing the specifications, and disassembling it, contact your MHIET dealer "[CONTACT LIST](#)" (→ [Page 10](#)). If the customer modifies the engine or changes the specifications, it could become impossible to ensure safety.
- Mitsubishi Heavy Industries Engine & Turbocharger, Ltd. (MHIET) cannot foresee all potential dangers of the engine, potential dangers resulting from human error and other causes, or a danger caused by a specific environment in which the engine is used.
- For the devices and facilities outside the scope of our supply, provide the corresponding manuals as "Usage Information" to the operators and let them obey the descriptions. MHIET will not bear a responsibility for damage or injury caused by the devices and facilities outside the scope of our supply.
- In some countries or regions, this engine cannot be used depending on the laws, regulations and installation environment. When transferring this engine to a third party, check the regional conditions of them and contact your MHIET dealer "[CONTACT LIST](#)" (→ [Page 10](#)).

Important Tips for Managing Safety of Work

- You must prepare a "Safety Manual", which describes your management criteria and operation rules. The supervisor must have the operators understand the "Safety Manual" preliminarily.
In addition, keep the manual at hand so the operator can read it whenever necessary.
- In order to prevent a disaster, the accident prevention measures must be suitable for the functions and specifications of this engine.
- The accident prevention activities must be as the occupational safety and health management system planned and performed organizationally and continuously. This occupational safety and health management system must include the following points:
 - (a) Proper location of this engine
 - (b) Instructions concerning maintenance and usage of the operators' personal protective equipment
 - (c) Organization of the operation management system such as preparation of operation standards, clarification of the operation command system, etc.
 - (d) Education and training of the operators
- Important purposes of the safety measures are to prevent personal injuries, protect the environment, and protect the engine. Always consider environmental protection.
- Mitsubishi Heavy Industries Engine & Turbocharger, Ltd. (MHIET) shall accept no responsibility for loss or injury resulting from not observing instructions in this manual, or not paying attention to commonly required precautions when operating, inspecting or maintaining this engine.

About This Manual

- This manual is intended for native speakers of the language in which the manual is written. If the operator of this engine is not a native speaker of the language used in this manual, the owner of the engine is requested to provide thorough safety guidance to the operator. Also prepare and affix warning labels written in the native language of the operators.
- MHIET possesses the copyright of this manual. All rights reserved. No part of this manual, including illustrations and technical descriptions, may be photocopied, translated, or reproduced, in whole or in part, in any electronic medium or machine readable form without prior written consent from MHIET.
- Illustrations in this manual may differ from the engine you have purchased. Covers can be omitted from illustrations to provide a better view of the inside.
- The contents of this manual are subject to change without any notice.
- When transferring this engine to a third party, make sure to attach this manual.
- Keep this manual in the usual place so that it can be used any time.
- If you need more information or if you have any questions, contact your MHIET dealer ["CONTACT LIST"](#) (→ Page 10).

WARRANTY PROVISIONS

1. Mitsubishi Heavy Industries Engine & Turbocharger, Ltd. (hereinafter referred to as MHIET) shall make a repair or replacement of a failure or damage at no charge, only when the said failure or damage occurs during the warranty period (refer to the individual contract) of this engine, and MHIET admits that its cause arises from the material, a problem of production, or a problem concerning our construction work within the scope of the contract specifications. The above-mentioned warranty period of this engine is not updated or prolonged by the said repair.
2. The above-mentioned warranty is the only one provided by MHIET concerning this engine.
No new contracts or warranties arise from this manual.
MHIET will not bear a responsibility for any loss (including, but not limited to direct loss, indirect loss, lost profits, operating losses, down time loss, etc.) caused by any reason, regardless of whether the warranty period is expired or not.
3. The warranty coverage is effective for the original purchaser only. Those to whom ownership is later transferred are not provided with the warranty.
4. We may deny the warranty coverage regardless of the warranty period if fault or damage has been caused to the engine by any reason mentioned below:
 - Fault or damage caused by operation or maintenance deviated from the instructions or cautions described in this manual
 - Fault or damage caused by being repaired or modified by other than us/MHIET dealer, or by illegal act
 - Fault or damage caused by abuse, misuse, incorrect operation or misapplication
 - Fault or damage caused by operation or maintenance beyond the specification limit
 - Fault or damage caused by use of spare parts, optional parts or consumables (including engine oil, LLC and fuel) that MHIET do not recommend
 - Operation with BDF which blending rate exceeds the required specification in Chapter 4 FUEL. (The warranty for any material or workmanship failure is subject to the deliberation of Mitsubishi Heavy Industries Engine & Turbocharger, Ltd.)
 - Fault or damage caused by a natural disaster (earthquake, typhoon, flood, seismic sea waves, volcanic eruption, etc.) fire, war, terrorism, or other abnormal operational conditions which MHIET cannot bear responsibility
 - Fault or damage caused by the location of this engine (for example, electromagnetic environment stress)
 - Fault or damage caused by resale or relocation
 - Fault or damage caused by consumption or age deterioration
 - Fault or damage caused by other reasons which MHIET cannot bear responsibility

EMISSION WARRANTY

The following warranty applies to the engines that have been certified to the emission regulation of the U.S. Environmental Protection Agency.

Mitsubishi Heavy Industries Engine & Turbocharger, Ltd. warrants to the ultimate purchaser and each subsequent purchaser that **the new non-road, stationary and emergency stationary engine**, including all parts of its emission-control system, meets two conditions:

- (1) It is designed, built, and equipped so it conforms at the time of sale to the ultimate purchaser with applicable regulation of the U.S. Environmental Protection Agency. If the vehicle in which the engine is installed is registered in the state of California, a separate California emission regulation also applies.
- (2) It is free from defects in materials and workmanship that may keep it from meeting these requirements.

Warranty Period

The emission warranty period is shown below.

However, if Mitsubishi Heavy Industries Engine & Turbocharger, Ltd.'s standard warranty period is longer than the emission warranty period, the emission warranty period extends to same as Mitsubishi Heavy Industries Engine & Turbocharger, Ltd.'s standard warranty period.

Below warranty period shall begin on the date **the new non-road, stationary and emergency stationary engine** is delivered to the ultimate purchaser.

If your engine is certified as...	And its maximum power is...	And its rated speed is...	Then its warranty period is... (whichever comes first.)	
			hours	years
Variable speed or constant speed	kW <19	Any speed	1500	2
Constant speed	19 ≤kW ≤37	3000 rpm or morer	1500	2
Constant speed	19 ≤kW ≤37	Less than 3000 rpm	3000	5
Variable speed	19 ≤kW ≤37	Any speed	3000	5
Variable speed or constant speed	37 ≤kW	Any speed	3000	5

Warranty Parts

Mitsubishi Heavy Industries Engine & Turbocharger, Ltd. warrants the parts which will increase the emission of pollutants when they become defective.

The followings are examples.

I All the engine parts relating to the systems below are included in the exhaust-gas related components:

1. Air-induction system
2. Fuel system
3. Ignition system
4. Exhaust gas recirculation systems

II The parts below are also included in the exhaust-gas related components:

1. After-treatment devices
2. Crankcase ventilation valves
3. Sensors
4. Electronic control units

III The parts below also included in the evaporative emission gas related components:

1. Fuel tank
2. Fuel cap
3. Fuel Line
4. Fuel Line Fittings
5. Clamps*
6. Pressure Relief Valves*
7. Control Valves*
8. Control Solenoids*
9. Electric Controls*
10. Vacuum Control Diaphragms*
11. Control Cables*
12. Control Linkages*
13. Purge Valves
14. Vapor Hoses
15. Liquid/Vapor Separator
16. Carbon canister
17. Canister Mounting Brackets
18. Carburetor Purge Port Connector

*Parts related to evaporation-emission-gas control system

Owner's Responsibility

*The owner of the engine is responsible for the performance of the required maintenance listed in this operation manual.

*In accordance with **40 CFR 89.1007**, Mitsubishi Heavy Industries Engine & Turbocharger, Ltd. makes no warranties if the operator caused the problem through improper maintenance or use.

CONTACT LIST

■ Europe

Netherland Mitsubishi Turbocharger and Engine Europe B.V. (MTEE) Damsluisweg 2, 1332 EC, Almere the Netherlands
TEL 31-36-5388-311 FAX 31-36-5388-200

■ North America

USA Mitsubishi Turbocharger and Engine America, Inc. (MTEA) Two Pierce Place, 11th Floor, Itasca, IL 60143 U.S.A.
TEL 1-630-268-0750 FAX 1-630-268-9293

■ South America

Brasil MHI Sul Americana Distribuidora de Motores Ltda. (MSA) Avenida Paulista, 1274-8°. Conj. 23, Sala C, Cep 01310-100, São Paulo, SP, Brasil
TEL 55-11-3515-7890 FAX 55-11-3515-7899

■ Asia

Singapore Mitsubishi Heavy Industries Engine System Asia Pte. Ltd. (MHIES-A) No.3, Tuas Avenue 12, Singapore 639024 Republic of Singapore
TEL 65-6862-2202 FAX 65-6862-5728

Vietnam MHI Engine System Vietnam Co., Ltd. (MHIES-V) 39 Dai Lo Huu Nghi, Vietnam-Singapore Industrial Park, Thuan An, District, Binh Duong Province Socialist Republic of Vietnam
TEL 84-650-3769251 FAX 84-650-3769262

Philippines MHI Engine System Philippines, Inc. (MHIES-P) Warehouse 4C. Sunblest Compound, KM23 West Service Road, Barangay Cupang, Muntinlupa City, Metro Manila Philippines
TEL 63-2-775-0209 FAX 63-2-775-0310

Indonesia PT. MHI Engine System Indonesia (MHIES-I) #302 Bld. Cilandak Commercial Estate P.O. Box 7510 CCE, Cilandak, Jakarta, Indonesia
TEL 62-21-7890-191 FAX 62-21-7890-279

UAE MHI Engine System Middle East FZE (MHIES-ME) Q4-44, Sharjah Airport International Free Zone (SAIF ZONE) P.O. Box 121801, Sharjah, UAE
TEL 971-6-548-9295 FAX 971-6-548-9294

■ China

China Mitsubishi Heavy Industries (Shanghai) Co., Ltd. (MHISH) 22nd floor, Office Tower 1, Raffles City Changning, No.1133 Changning Road, Changning District, Shanghai, 200051, China
TEL 86-21-6236-9799 FAX 86-21-6841-5222

MODEL NAME

In this manual, different models of the same series are described. Please check the model name and other details with the nameplate on this engine, and fill in "[SPECIFICATIONS - CHECK](#)" (→ [Page 12](#)).

■ Location of Nameplate

The nameplate is located on the lateral side of the engine, and indicates the following information:

- Serial number
- Manufactured date
- Model name
- Rated output
- Rated speed

<Engine Top View>

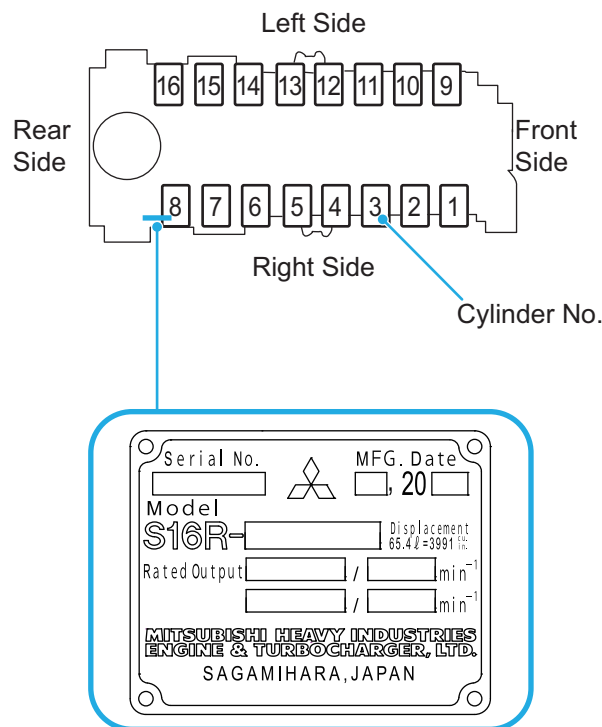

*Above illustration shows S16R nameplate.

Fig. 1 Location of Nameplate

EMISSION CONTROL APPROVAL LABEL

The emission control approval label is attached on the model obtained a certificate of conformity to EPA or CARB regulations of USA.

When handling the label, you have to take care that the label will not get dirty or peeled off. Otherwise, the label may become impossible to prove the exhaust gas performance, and result in a violation of the laws and regulations.

In case that the label gets dirty or peeled off, the label must be stored as it is, and you must immediately contact your MHIET dealer "[CONTACT LIST](#)" (→ [Page 10](#)).

■ Location of Emission Control Approval Label

The emission control approval label is attached on the location below.

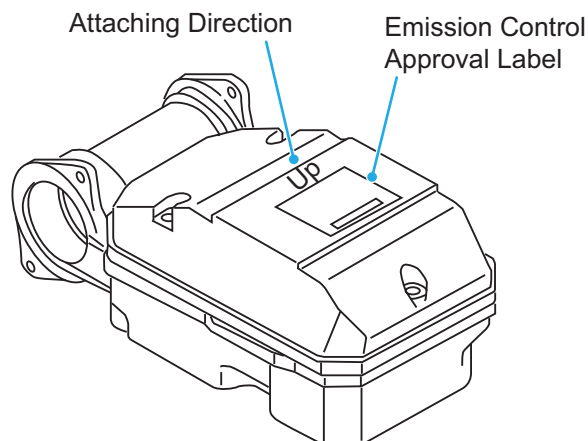

Fig. 2 Attaching location of Emission Control Approval Label

SPECIFICATIONS - CHECK

Main Specifications

Table 1 Main Specifications

Engine model	S16R
Type	Water-cooled, 4-cycle stroke, turbocharged diesel engine
No. of cylinders - Arrangement	16-V
Cylinder bore x stroke	ø170 × 180 mm [6.69 × 7.09 in.]
Total displacement	65.37 L [3989.72 cu in.]
Combustion system	Direct injection system
Compression ratio	13.5 : 1, 14.0 : 1, 14.5 : 1, 15.0 : 1
Firing order	1 - 9 - 6 - 14 - 2 - 10 - 4 - 12 - 8 - 16 - 3 - 11 - 7 - 15 - 5 - 13
Direction of rotation	Counterclockwise as viewed from flywheel side
Damper	Double damper, damper with spacer
Fuel injection pump	Mitsubishi PS8 type
Fuel injection nozzle	Hole type
Fuel injection starting pressure	34.3 MPa {349.76 kgf/cm ² } [4974.80 psi]
Fuel filter	Paper element type
Lubricating method	Forced lubrication (pressure feed by oil pump)
Oil filter	Paper element type
Oil cooler	Water-cooled, multi-plate type
Cooling method	Forced water cooling

Detailed Specifications

The detailed specifications vary depending on your devices. Refer to the specification sheet prepared by the generator supplier, and fill in below.

- Mark into of the corresponding item.
- If there is not an item to be selected, enter into or a blank directly.

Specifications of Engine Body

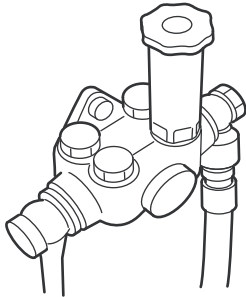
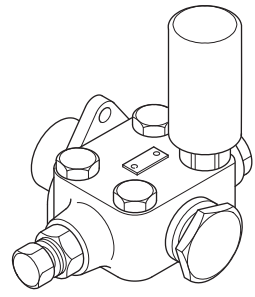
- **Model Name**
 - **Serial Number**
 - **Manufacturing Date**
 - **Dimensions (L x W x H)** mm x mm x mm
 - **Dry Weight** kg
 - **Purpose and Intended Use** Continuous use engine Emergency use engine
 - **Rated Output** kW
 - **Rated Speed** min⁻¹
 - **Generator Frequency** Hz
 - **Installation Situation** Stationary Cubicle (bonnet type)
 - **Starting System** Self Starter Motor Starting Air Direct Admission Starting
 Air Motor Starting
 - **Fuel** Diesel fuel
 - **Priming Pump Type** Type A (with locking mechanism) Type B (without locking mechanism)
- 

- **Governor** Mechanical/hydraulic type Electric type
 - **Oil Pan** Standard type Large type
 - **Engine Oil Capacity** L (Oil pan capacity) L (Engine total)
 - **Engine Oil Grade** Grade
 - **Coolant Capacity** L

Additional Equipment of Generator

- **Fuel System**
 - Fuel day tank
 - Water separator
- **Lubrication System**
 - Oil tank
 - Oil level regulator
 - Priming pump
 - Mist separator
- **Cooling System**
 - Expansion tank
 - Metal fan Resin fan
 - Radiator
 - Reserve tank
 - Heat exchanger
 - Water heater
- **Air Intake System**
 - Air cleaner
 - Silencer, Pre-cleaner
 - Air heater
- **Exhaust System**
 - Flue piping, External smoke equipment
 - Muffler, Silencer
- **Air Starter System**
 - Air tank
 - Air compressor
 - Air filter
 - Air motor
- **Electrical System**
 - Control panel, Operation panel, Instrument panel
 - Battery, Battery switch
- **Protection Devices**
 - Oil pressure switch
 - Oil filter alarm switch
 - Thermo switch
 - Rotation detection pickup

Protection Devices Added during Manufacturing the Generator

Please read first

Please compile the information about the protection devices added during manufacturing the generator and attach it on this page.

DEFINITION OF INTENDED PERSONS

We have defined and classified the persons related to this engine for the safety as follows:

■ "User Company or Supervisor":

Means a person, who maintains and manages this engine, conducts safety management for operators, prevents emergency situation (fire, etc.), and takes actions in the event of emergency to minimize damage.

The user company or supervisor prepares the "Safety Manual", and then performs periodic safety guidance to the operators and management of the safety tools and jigs accordingly.

■ "Operator":

Means a person, who has sufficient knowledge about this engine, and the technique of operation, inspection and maintenance.

The operator is allowed to perform a simple troubleshooting of this engine and scheduled maintenance in addition to operation works. The operator is allowed to bring this engine to an emergency stop, when he/she has found critical situation.

Before working, the operator must read the "Safety Manual" and this manual thoroughly to understand the special features of this engine and all the details of works sufficiently.

■ "Customers":

Means the user company, supervisor and operator mentioned above.

■ "Service Personnel or MHIET Dealer":

Means a person who is certified by our service personnel or us, and who gives guidance and performs the commissioning test as a site manager of installation, a test run and others of this engine, and after installation and commissioning test, also gives operating guidance to the customers, operating instructions, maintenance, overhaul and other works.

■ "Installation Contractor or generator Supplier":

Means a person to whom this engine is supplied by MHIET, and who manufactures and sells the generator.

This manual is intended for use by the user company, supervisor and operator.

For other service documents, refer to ["STRUCTURE OF SERVICE DOCUMENTS" \(→ Page 17\)](#).

STRUCTURE OF SERVICE DOCUMENTS

The service documents concerning this engine is structured as follows.

Please use the required service documents in accordance with your situation.

To acquire the service documents, contact your MHIET dealer "[CONTACT LIST](#)" (→ [Page 10](#)).

Please use this engine referring to the completion book of the generator in addition to them.

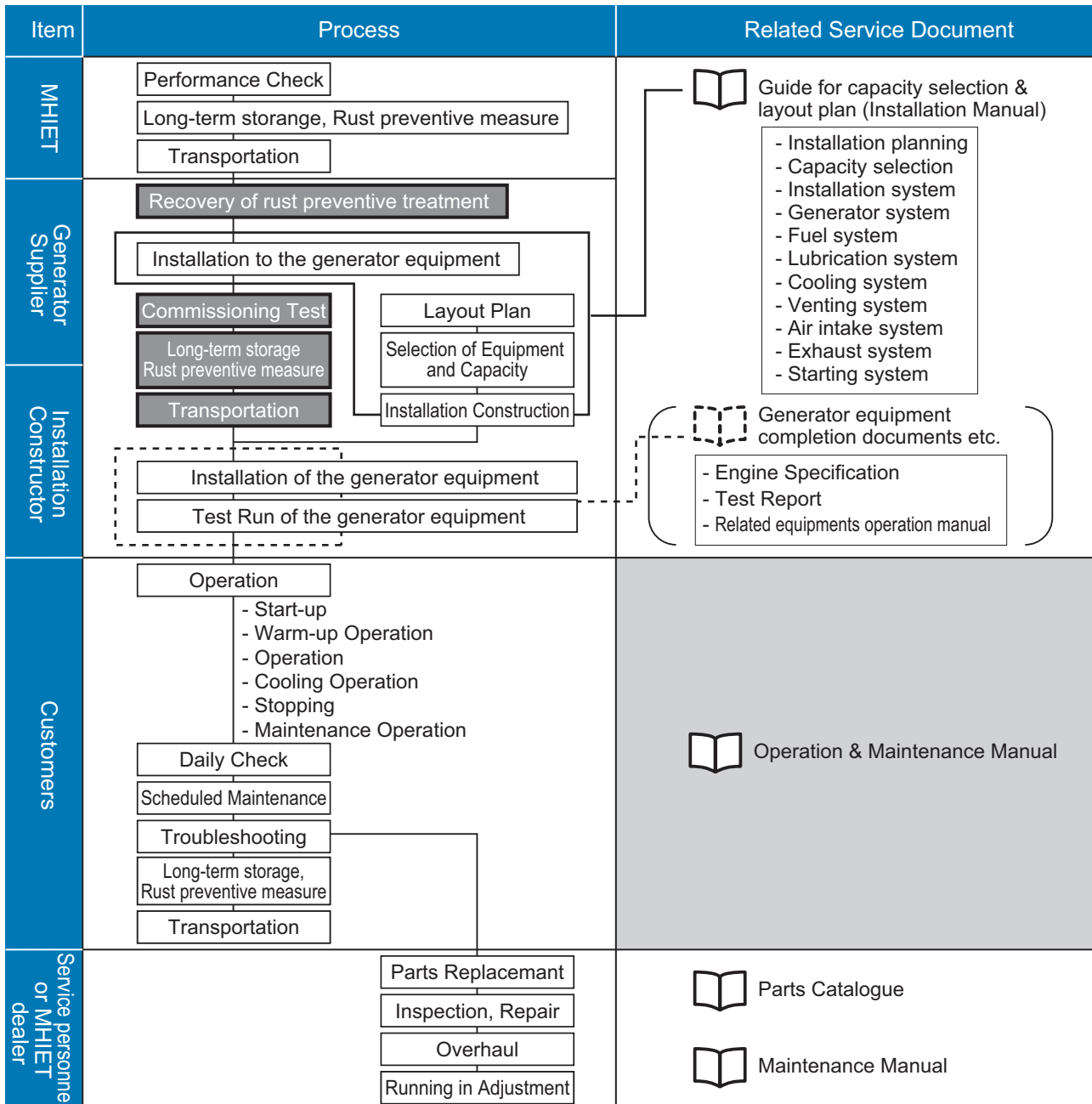

 : No documents available. To be prepared later.

 : Confirm to the equipment supplier.

Fig. 1 Structure of Service Documents

STRUCTURE OF THIS MANUAL

This manual is constructed as follows:

1 SAFETY.....	<u>29</u>
2 ENGINE - OUTLINE.....	<u>76</u>
3 OPERATION.....	<u>88</u>
4 FUEL.....	<u>104</u>
5 ENGINE OIL.....	<u>110</u>
6 COOLANT.....	<u>112</u>
7 SCHEDULED MAINTENANCE.....	<u>118</u>
8 INSPECTION AND MAINTENANCE.....	<u>124</u>
9 LONG-TERM STORAGE.....	<u>172</u>
10 TRANSPORTATION.....	<u>176</u>
11 TROUBLESHOOTING.....	<u>179</u>
12 AFTER-SALES SERVICE.....	<u>194</u>
13 DISPOSAL.....	<u>195</u>
14 APPENDIX.....	<u>198</u>

LIST OF MODELS

The following models are covered in this manual.

Check the model name.

For the “models conforming to the exhaust gas standards”, see corresponding items.

Table 1 List of Models (1/2)

Model name	Exhaust gas regulations	intended use	Supercharging method	Cooling method	
S16R	Y1PTA	Conformed to EPA exhaust gas Tier 1 standards	Generator	Turbocharging	Aftercooler
	Y1PTA-1	Conformed to EPA exhaust gas Tier 1 standards	Generator	Turbocharging	Aftercooler
	Y1PTA-2	Conformed to EPA exhaust gas Tier 1 standards	Generator	Turbocharging	Aftercooler
	Y1PTA-3	Conformed to EPA exhaust gas Tier 1 standards	Generator	Turbocharging	Aftercooler
	Y1PTA-4	Conformed to EPA exhaust gas Tier 1 standards	Generator	Turbocharging	Aftercooler
	Y1PTAA2	Conformed to EPA exhaust gas Tier 1 standards	Generator	Turbocharging	Air-to-air intercooler
	Y1PTAA2-1	Conformed to EPA exhaust gas Tier 1 standards	Generator	Turbocharging	Air-to-air intercooler
	Y1PTAA2-3	Conformed to EPA exhaust gas Tier 1 standards	Generator	Turbocharging	Air-to-air intercooler

Table 2 List of Models (2/2)

Model name		Exhaust gas regulations	intended use	Supercharging method	Cooling method
S16R	Y2PTAW	Conformed to EPA exhaust gas Tier 2 standards	Generator	Turbocharging	Dualline cooling system (Jacket cooling, air cooling)
	Y2PTAW-1	Conformed to EPA exhaust gas Tier 2 standards	Generator	Turbocharging	Dualline cooling system (Jacket cooling, air cooling)
	Y2PTAW2	Conformed to EPA exhaust gas Tier 2 standards	Generator	Turbocharging	Dualline cooling system (Jacket cooling, air cooling)
	Y2PTAW2-1	Conformed to EPA exhaust gas Tier 2 standards	Generator	Turbocharging	Dualline cooling system (Jacket cooling, air cooling)

UNIT OF MEASUREMENT

In this manual, the SI System (International Unit System) is basically used for the units of measurement. The conversion rates between the SI system and other conventional systems are given below.

[Pressure] 1 MPa = 10.197 kgf/cm²

[Torque] 1 N·m = 0.10197 kgf·m

[Force] 1 N = 0.10197kgf

[Horsepower] 1 kW = 1.341 HP = 1.3596 PS

[Pressure (meter of mercury)] 1 kPa = 0.75 cmHg

[Pressure (meter of water)] 1 kPa = 10.197 cmH₂O (cmAq)

[Rotating speed] 1 min⁻¹ = 1 rpm

[Kinetic viscosity] 1 mm²/s = 1 cSt

ABBREVIATIONS AND STANDARDS

- API = American Petroleum Institute
- ASTM = ASTM International
- ISO = International Organization for Standardization
- CARB = California Air Resources Board
- EPA = United States Environmental Protection Agency
- JIS = Japanese Industrial Standards
- LLC = Long Life Coolant
- MHI = Mitsubishi Heavy Industries, Ltd.
- MHIET = Mitsubishi Heavy Industries Engine & Turbocharger, Ltd.
- OSHA = Occupational Safety and Health Administration
- SAE = Society of Automotive Engineers
- SDS = Safety Data Sheet

CONTENTS

FOREWORD	3	UNIT OF MEASUREMENT	21
IMPORTANT INFORMATION	4	ABBREVIATIONS AND STANDARDS	21
Intended Purpose and Use	4		
General	4		
Important Tips for Safety of Work	5		
To the User Company	5		
General	5		
Important Tips for Managing Safety of Work	6		
About This Manual	6		
WARRANTY PROVISIONS	7		
EMISSION WARRANTY	8		
CONTACT LIST	10		
MODEL NAME	11		
EMISSION CONTROL APPROVAL LABEL	11		
SPECIFICATIONS - CHECK	12		
Main Specifications	12		
Detailed Specifications	13		
Specifications of Engine Body	13		
Additional Equipment of Generator	14		
Protection Devices Added during Manufacturing the Generator	15		
DEFINITION OF INTENDED PERSONS	16		
STRUCTURE OF SERVICE DOCUMENTS	17		
STRUCTURE OF THIS MANUAL	18		
LIST OF MODELS	19		
		1	SAFETY
			General Information 29
			Warnings 29
			Types and Meanings of Warning Terms 29
			Warning Labels 30
			Matters to Be Obeyed and Matters Prohibited 32
			Safety Cautions 32
			Preparation for Emergencies 32
			Precautions for Covers 33
			Precautions for Fire Sources 33
			Precautions Regarding the Environment 33
			Precautions for Personal Protective Equipment 33
			Precautions for Protection Devices 34
			Precautions for Battery 34
			Precautions for Warning Labels 35
			Other Precautions 35
			Precautions for Auxiliary Facilities of the Generator 35
			OPERATION 36
			FUEL 42
			ENGINE OIL 44
			COOLANT 45
			SCHEDULED MAINTENANCE 45
			INSPECTION AND MAINTENANCE 46
			LONG-TERM STORAGE 55
			TRANSPORTATION 56
			TROUBLESHOOTING 57
			DISPOSAL 58
			Protection Devices 60
			Protection Devices on the Engine 60

Lockout/Tagout	62
Lockout	62
Tagout	62
Zero Energy State	63
How to Set the Engine to Zero Energy State	63
Working Procedure in Dangerous Areas... ..	63
Works in Dangerous Areas	63
Body Protection	64
Clothing	64
Personal Protective Equipment	64
Product-specific Precautions	65
Use of Chemicals	65
Surface Temperature	65
Precautions on Additional Equipment	65
Water Heater	65
Develop the Action Procedure to Obey in the Event of Emergency	66
Keep Everyone Informed about the Emergency Stop Procedure	66
Measures in the Event of Emergency	66
Emergency Stop Procedure	66
Emergency Stopping Devices Installed during Manufacturing the Generator	67
Measures in the Event of Personal Injuries Resulting from This Engine	68
Measures in the Event of Property Damaging Disasters	68
Measures in the Event of Environmental Disaster	69
Measures in the Event of a Fire Disaster Resulting from This Engine	69
Measures in the Event of an Earthquake Disaster	70
Occupational Health and Safety Management	71
Operation & Maintenance Manual - Understand and Obey	71
Education and Training for Safety	71
Dangerous and Hazardous Chemicals	72
Noise	73
Vibration	74
To Maintain Cleanliness and Tidiness	74
Risk of Fire	75
Communication with MHIET	75

2	ENGINE - OUTLINE
	Names of Parts
	S16R-Y1PTA, S16R-Y1PTA-1, S16R-Y1PTA-2, S16R-Y1PTA-3, S16R-Y1PTA-4
	S16R-Y1PTAA2, S16R-Y1PTAA2-1, S16R-Y1PTAA2-3
	S16R-Y2PTAW, S16R-Y2PTAW-1, S16R-Y2PTAW2, S16R-Y2PTAW2-1
	Protection System - Location
	S16R-Y1PTA, S16R-Y1PTA-1, S16R-Y1PTA-2, S16R-Y1PTA-3, S16R-Y1PTA-4
	S16R-Y1PTAA2, S16R-Y1PTAA2-1, S16R-Y1PTAA2-3
	S16R-Y2PTAW, S16R-Y2PTAW-1, S16R-Y2PTAW2, S16R-Y2PTAW2-1
	Starting and Stopping Devices Installed during Manufacturing the Generator
3	OPERATION
	Operation - Outline
	Daily Check
	Operational Environment - Check
	Engine Exterior - Check
	Pre-operation Check
	Fuel Tank Oil Level - Check
	Fuel Control Link - Check
	Engine Oil Level - Check
	Coolant Level - Check
	Battery - Check
	Pre-cleaner - Check for Clogging
	Air Cleaner - Check for Clogging
	Damper Temperature - Check
	Manual Turning Gear - Check
	Air Direct Admission Starting - Check
	Air Motor Starting - Check
	Engine Start-up
	Self Starter Motor Starting
	Air Direct Admission Starting
	Air Motor Starting
	Warm-up Operation
	Operation
	Checking during Operation
	Cooling Operation
	Stopping

Checking after Stopping.....	103		
Maintenance Operation.....	103		
4 FUEL			
Fuel.....	104		
Diesel Fuel (Emission Control Approved Model)	104		
Diesel Fuel.....	105		
Fuel - Handling.....	106		
Fuel - Refill.....	106		
Fuel Quality Standard	107		
5 ENGINE OIL			
Engine Oil	110		
Engine Oil Grade	110		
Engine Oil Viscosity	111		
Handling Engine Oil	111		
6 COOLANT			
Water to Be Used.....	112		
LLC to Be Used.....	113		
Coolant (LLC) - Handling	113		
Maintenance of LLC.....	114		
LLC Concentration in Coolant - Check ...	114		
Replacement Period	114		
Coolant - Mix.....	114		
LLC Concentration (Genuine LLC)	114		
LLC Concentration in Coolant - Measure	115		
Tool - Adjust.....	115		
Measurement.....	116		
7 SCHEDULED MAINTENANCE			
How to Use the Scheduled Maintenance	118		
Category of Scheduled Maintenance Chart	119		
Rating Definition.....	120		
Scheduled Maintenance for EPA Compliant Generator Use Diesel Engine ..	122		
		8 INSPECTION AND MAINTENANCE	
		Inspection and Maintenance - General Information	124
		Precautions for General Inspection and Maintenance	125
		Inspection and Maintenance - Prepare ...	126
		Inspection and Maintenance - Prepare (with Engine Switched ON)	126
		Inspection and Maintenance - Prepare (with Engine Switched OFF).....	127
		Engine Body - Check	127
		Belt - Check.....	127
		Belt Tension (Alternator) - Adjust	129
		Damper - Check	132
		Damper Temperature - Check.....	132
		Fuel System - Check.....	133
		Fuel tank - Check and Service	134
		Fuel System - Bleed Air.....	134
		Water Separator - Check and Service....	138
		Gauze Filter - Clean	139
		Fuel Filter - Replace	140
		Fuel Control Link - Check.....	142
		Fuel Pipe - Check.....	144
		Engine Oil System - Check	146
		Engine Oil - Change	147
		Oil Filter - Replace.....	151
		Bypass Oil Filter - Replace	153
		Governor Oil Filter - Replace (Hydraulic Governor Spec).....	153
		Oil Pipe - Check	155
		Cooling System - Check	155
		Corresponding Equipment - Location.....	156
		Coolant - Change	156
		Cooling System - Bleed Air	162
		Radiator Fins - Check and Clean (Radiator Spec)	163
		Resin Fan Inspection (Specifications with Resin Fan)	164
		Intake and Exhaust Systems - Check ...	165
		Turbocharger - Check	165
		Exhaust Muffler - Drain Water	166
		Pre-cleaner - Check and Service	166
		Air Cleaner - Check and Service	168

Electrical System - Check	168		
Battery - Check	168		
Starter - Check (Self Starter Motor Starting)	169		
Alternator - Check	169		
Air Direct Admission Starting, Air Motor Starting - Check	170		
Air Strainer - Drain Water and Clean	170		
Starting Air Tank - Check and Service (Air Direct Admission Starting, Air Motor Starting)	171		
Starting Air Motor - Check (Air Motor Starting)	171		
9 LONG-TERM STORAGE			
Storing Engine in Inoperable Condition ..	172		
Storage - Prepare (Rust-preventive Measure)	172		
Storage	174		
Maintenance during Storage	174		
Restart after Storing	174		
Storing Engine in Operable Condition ...	175		
10 TRANSPORTATION			
Precautions on Transportation	176		
Engine - Lift	176		
11 TROUBLESHOOTING			
Precautions on Troubleshooting	179		
How to Troubleshoot	180		
Troubleshooting	181		
Starter Does Not Crank or Cranks Slowly, Resulting in Starting Failure	181		
Starter Cranks, but Engine Does Not Start	182		
Output Shortage	183		
Exhaust Smoke is White or Blue	185		
Exhaust Smoke is Black or Dark Grey	186		
Excessive Fuel Consumption	188		
Excessive Engine Oil Consumption	189		
Overheating	190		
Engine Oil Pressure Drop	191		
Engine Stops	192		
During Normal Operation, Thermo Switch Activated	193		
		12 AFTER-SALES SERVICE	
		Supply of Performance Parts for Repair ...	194
		Supply Period	194
		Parts That Reached the Supply Period ...	194
		When Requesting Repair	194
		Inquiry Counter	194
		13 DISPOSAL	
		Disposal Precautions	195
		Wastes Produced during Inspection and Maintenance	197
		Engine Body - Disposal	197
		14 APPENDIX	
		Engine Oil	198
		Engine Oil Quality Standards	199
		Service Limit for Engine Oil Properties ...	200
		Service Limits for Engine Oil	201
		Engine Oil Service Limits for Emergency Use	202
		Coolant	203
		Requirements for LLC	203
		LLC Quality Standard	203
		Necessity of LLC	207
		Characteristics of LLC Additives	207
		Examples of Abnormalities Caused by LLC (Amine Type)	207
		REVISION HISTORY	

List of Illustrations

Fig. 1	Location of Nameplate.....	11	Fig. 6-5	Tool - Adjust 3.....	116
Fig. 2	Attaching location of Emission Control Approval Label11		Fig. 6-6	Tool - Adjust 4.....	116
Fig. 1	Structure of Service Documents.....	17	Fig. 6-7	Tool - Adjust 5.....	116
Fig. 1-1	Warning Labels and Their Locations (Examples)	31	Fig. 6-8	Tool - Adjust 6.....	116
Fig. 1-2	Oil Pressure Switch	61	Fig. 6-9	LLC Concentration Measurement 1	116
Fig. 1-3	Thermo Switch.....	61	Fig. 6-10	LLC Concentration Measurement 2	116
Fig. 1-4	Oil Filter Alarm Switch	61	Fig. 6-11	LLC Concentration Measurement 3	117
Fig. 1-5	Rotation Detection Pickup	61	Fig. 6-12	LLC Concentration Measurement 4	117
Fig. 1-6	Lockout/Tagout (Example)	62	Fig. 6-13	LLC Concentration Measurement 5	117
Fig. 1-7	Clothing	64	Fig. 6-14	LLC Concentration Measurement 6	117
Fig. 1-8	Personal Protective Equipment	64	Fig. 8-1	Belt Tension - Adjust (V-belt)	128
Fig. 1-9	Emergency Stop Procedure	66	Fig. 8-2	Shape of V-belt	128
Fig. 1-10	Measures in the Event of Personal Injury ...	68	Fig. 8-3	Belt Tension - Adjust (Ribbed Belt).....	128
Fig. 1-11	Measures in the Event of Property Damaging Disasters	68	Fig. 8-4	Shape of Ribbed Belt	128
Fig. 1-12	Measures in the Event of Environmental Disaster	69	Fig. 8-5	Belt Cover - Remove.....	129
Fig. 1-13	Measures in the Event of a Fire Disaster.....	69	Fig. 8-6	Belt Tension - Adjust (Retaining Bolt) ...	129
Fig. 1-14	Measures in the Event of an Earthquake Disaster.....	70	Fig. 8-7	Belt Tension - Adjust (Lock Nut)	129
Fig. 1-15	Operation & Maintenance Manual - Understand and Obey	71	Fig. 8-8	Belt Tension - Adjust (Turn Buckle)	129
Fig. 1-16	Education and Training for Safety	71	Fig. 8-9	Belt Tension - Adjust (Lock Nut)	130
Fig. 1-17	Hazardous Chemical Substances	72	Fig. 8-10	Belt Tension - Adjust (Retaining Bolt) ...	130
Fig. 1-18	Noise	73	Fig. 8-11	Belt Cover - Install.....	130
Fig. 1-19	Vibration	74	Fig. 8-12	Front cover - Install	130
Fig. 1-20	To maintain cleanliness and tidiness.....	74	Fig. 8-13	Damper - Check.....	132
Fig. 1-21	Fire Hazard.....	75	Fig. 8-14	Thermo Label - Stick.....	133
Fig. 1-22	Communication with MHIET	75	Fig. 8-15	Priming Pump	135
Fig. 3-1	Pre-cleaner - Check for Clogging	94	Fig. 8-16	Priming Pump - Operation <A-type>....	135
Fig. 3-2	Manual Turning Gear - Check	95	Fig. 8-17	Priming Pump - Operation <A-type>....	135
Fig. 3-3	Air Motor Muffler	98	Fig. 8-18	Priming Pump - Operation <A-type>....	135
Fig. 4-1	ULSD Label	105	Fig. 8-19	Priming Pump - Operation <A-type>....	135
Fig. 5-1	Ambient Temperature and Engine Oil Viscosity	111	Fig. 8-20	Priming Pump - Operation <A-type>....	136
Fig. 6-1	Freezing Temperature of GLASSY.....	115	Fig. 8-21	Priming Pump - Operation <B-type>....	136
Fig. 6-2	Freezing Temperature of PG GLASSY ...	115	Fig. 8-22	Fuel Filter - Bleed Air (1).....	136
Fig. 6-3	Tool - Adjust 1	115	Fig. 8-23	Fuel Filter - Bleed Air (2).....	136
Fig. 6-4	Tool - Adjust 2	115	Fig. 8-24	Fuel Injection Pump - Bleed Air 1	137
			Fig. 8-25	Fuel Injection Pump - Bleed Air 2	137
			Fig. 8-26	Fuel Injection Pump - Bleed Air 3	137
			Fig. 8-27	Banjo Bolt - Remove	139
			Fig. 8-28	Gauze Filter - Remove	139
			Fig. 8-29	Hose Joint	140
			Fig. 8-30	Banjo Bolt - Install	140
			Fig. 8-31	Around Fuel Filter - Clean.....	141

Fig. 8-32	Container to Receive Fuel	141	Fig. 8-72	Case - Install	154
Fig. 8-33	Fuel Filter - Remove	141	Fig. 8-73	Oil Pipe - Install.....	154
Fig. 8-34	Fuel Filter Installing Surface - Clean	141	Fig. 8-74	Drain Plug - Install.....	154
Fig. 8-35	Fuel Filter Gasket	141	Fig. 8-75	Air Vent Plug - Remove	154
Fig. 8-36	Fuel Filter - Install	142	Fig. 8-76	Air Vent Plug - Install	154
Fig. 8-37	Fuel Filter Installing Surface - Check....	142	Fig. 8-77	Clip Attaching Direction.....	155
Fig. 8-38	Fuel Control Link - Check	143	Fig. 8-78	Oil Pipe - Check.....	155
Fig. 8-39	Manual Stop Lever - Operate	143	Fig. 8-79	<S16R-Y1PTA - Right-Side View>	156
Fig. 8-40	Manual Stop Lever - Check.....	143	Fig. 8-80	<S16R-Y1PTA - Left-Side View>.....	156
Fig. 8-41	Ball Joint - Check.....	143	Fig. 8-81	Coolant Drain Cock on Engine Body ...	156
Fig. 8-42	Ball Joint - Remove	144	Fig. 8-82	Coolant Drain Cock on Water Pump....	156
Fig. 8-43	Ball Joint and Washer - Remove	144	Fig. 8-83	Container to Receive Coolant	157
Fig. 8-44	Ball Joint - Fix	144	Fig. 8-84	Coolant Drain Cock on Water Pump....	157
Fig. 8-45	Clamp and Seat - Check	144	Fig. 8-85	Radiator Cap - Pressure Release (With Lever)	157
Fig. 8-46	High Pressure Fuel Injection Pipe Clamp - Location	145	Fig. 8-86	Radiator Cap - Pressure Release (Without Lever)	157
Fig. 8-47	High Pressure Fuel Injection Pipe - Check	146	Fig. 8-87	Coolant Drain Cock on Engine Body ...	157
Fig. 8-48	Clip Attaching Direction	146	Fig. 8-88	Coolant Drain Cock on Water Pump....	157
Fig. 8-49	Low Pressure Fuel Pipe - Check	146	Fig. 8-89	Coolant Drain Cock on Engine Body ...	158
Fig. 8-50	<S16R-Y1PTA - Right-Side View>	147	Fig. 8-90	Coolant Drain Cock on Water Pump....	158
Fig. 8-51	<S16R-Y1PTA - Left-Side View>	147	Fig. 8-91	Coolant Drain Cock on Water Pump....	158
Fig. 8-52	Oil Filler Cap - Remove	148	Fig. 8-92	Container to Receive Tap Water.....	159
Fig. 8-53	Rocker Cover - Remove	148	Fig. 8-93	Coolant Drain Cock on Engine Body ...	159
Fig. 8-54	Engine Oil - Apply (Valve Mechanism)....	148	Fig. 8-94	Coolant Drain Cock on Water Pump....	159
Fig. 8-55	Engine Oil - Apply (Camshaft Oil Bath) ...	149	Fig. 8-95	Coolant Drain Cock on Engine Body ...	159
Fig. 8-56	Rocker Cover - Install	149	Fig. 8-96	Coolant Drain Cock on Water Pump....	159
Fig. 8-57	Engine Oil Level - Check	149	Fig. 8-97	Coolant Drain Cock on Water Pump....	160
Fig. 8-58	Oil Level Gauge.....	150	Fig. 8-98	Container to Receive Tap Water.....	160
Fig. 8-59	Oil Filler Cap - Install	150	Fig. 8-99	Coolant Drain Cock on Engine Body ...	160
Fig. 8-60	Engine - Adjust after Oil Change	150	Fig. 8-100	Coolant Drain Cock on Water Pump....	160
Fig. 8-61	Around Oil Filter - Clean	151	Fig. 8-101	Coolant Drain Cock on Engine Body ...	161
Fig. 8-62	Container to Receive Engine Oil	152	Fig. 8-102	Coolant Drain Cock on Water Pump....	161
Fig. 8-63	Oil Filter - Remove.....	152	Fig. 8-103	Coolant Drain Cock on Engine Body ...	161
Fig. 8-64	Oil Filter Installing Surface - Clean	152	Fig. 8-104	Coolant Drain Cock on Water Pump....	161
Fig. 8-65	Oil Filter Gasket.....	152	Fig. 8-105	After Coolant Change - Adjust	162
Fig. 8-66	Oil Filter - Install.....	152	Fig. 8-106	Radiator Fin	163
Fig. 8-67	Engine Oil - Drain	153	Fig. 8-107	Radiator Fin - Clean.....	164
Fig. 8-68	Oil Pipe - Remove	153	Fig. 8-108	Blade Mounting Portion.....	165
Fig. 8-69	Center Bolt - Remove	153	Fig. 8-109	Turbocharger - Check	166
Fig. 8-70	Element - Pull Out	153	Fig. 8-110	Pre-cleaner - Check for Clogging.....	166
Fig. 8-71	Element - Install.....	154	Fig. 8-111	Pre-cleaner - Remove	167

Fig. 8-112 Pre-cleaner - Clean 1 167

Fig. 8-113 Pre-cleaner - Clean 2 167

Fig. 8-114 Pre-cleaner - Clean 3 167

Fig. 8-115 Pre-cleaner - Install 167

Fig. 8-116 Starter - Check
(Self Starter Motor Starting)..... 169

Fig. 8-117 Alternator - Check..... 169

Fig. 8-118 Drain Plug - Remove 170

Fig. 8-119 Cap and Filter - Remove 170

Fig. 9-1 Rocker Cover - Remove 174

Fig. 9-2 Engine Oil - Apply (Valve Mechanism)... 175

Fig. 9-3 Rocker Cover - Install 175

Fig. 9-4 Restart after Storing 175

Fig. 10-1 Engine's Center of Gravity..... 178

Fig. 13-1 Engine Body - Disposal 197

Table 8-1 Type of Belt (V-belt) 128

Table 8-2 Type of Belt (Ribbed Belt)..... 128

Table 8-3 Ribbed Belt Tensile Force..... 131

Table 8-4 Limit Temperature of Damper 132

Table 8-5 Types of Thermo Labels 133

Table 8-6 Corresponding Equipment 147

Table 8-7 Corresponding Equipment - Location .. 156

Table 11-1 Starter Does Not Crank or Cranks
Slowly, Resulting in Starting Failure 181

Table 11-2 Starter Cranks, but Engine Does Not
Start 182

Table 11-3 Output Shortage (1/2) 183

Table 11-4 Output Shortage (2/2) 184

Table 11-5 Exhaust Smoke is White or Blue..... 185

Table 11-6 Exhaust Smoke is Black or Dark Grey
(1/2)..... 186

Table 11-7 Exhaust Smoke is Black or Dark Grey
(2/2)..... 187

Table 11-8 Excessive Fuel Consumption..... 188

Table 11-9 Excessive Engine Oil Consumption 189

Table 11-10 Overheating 190

Table 11-11 Engine Oil Pressure Drop 191

Table 11-12 Engine Stops..... 192

Table 11-13 During Normal Operation, Thermo
Switch Activated..... 193

Table 14-1 Engine Oil Quality Standards 199

Table 14-2 Engine Oil Properties 201

Table 14-3 Engine Oil Service Limits for
Emergency use 202

Table 14-4 LLC Specifications (1/3) 204

Table 14-5 LLC Specifications (2/3)..... 205

Table 14-6 LLC Specifications (3/3)..... 206

List of Tables

Table 1 Main Specifications..... 12

Table 1 List of Models (1/2)..... 19

Table 2 List of Models (2/2)..... 20

Table 1-1 Types and Meanings of Warning Terms... 29

Table 1-2 Meanings of Symbols 30

Table 3-1 Limit Temperature of Damper..... 94

Table 3-2 Checking During Operation 102

Table 4-1 Fuel Properties Table
(Emission Control Approved Model)..... 105

Table 4-2 Fuel Properties Limit Table..... 105

Table 4-3 Fuel Specifications 105

Table 4-4 Fuel Properties Table (1/2)..... 107

Table 4-5 Fuel Properties Table (2/2)..... 108

Table 6-1 Water Quality Standard 112

Table 6-2 LLC Concentration..... 114

Table 6-3 Scale Conversion Table 117

Table 7-1 MHIET Generator Use Diesel Engine
Rating Definition (1/2)..... 120

Table 7-2 MHIET Generator Use Diesel Engine
Rating Definition (2/2)..... 121

Table 7-3 Maintenance Schedule (1/2)..... 122

Table 7-4 Maintenance Schedule (2/2)..... 123

1 SAFETY

This chapter describes the required safety instructions for handling the engine.

General Information

The safety instructions given here provide operators with guidelines for preventing personal injury.

In order to operate this engine according to your own Occupational Safety and Health Management System, not only the information for safety, operation, inspection and maintenance work described in this manual but also use them in combination with the regular safety education and training.

Warnings

In order to call the attention to the operator's risks, the following two options are reserved in this engine.

- Warning descriptions in this Operation & Maintenance Manual
- Warning labels on the engine and the devices

Read carefully all the safety-related warnings described in this Operation & Maintenance Manual. Before operating the engine, make sure of the locations and contents of all the warning labels affixed to the engine and the devices.

In order to ensure safety and prevent damage to the machine, the categories (DANGER, WARNING, CAUTION, and Note) explained in "[Types and Meanings of Warning Terms](#)" (→ [Page 29](#)) and their text are described in this Operation & Maintenance Manual.

Understand and obey the details of warnings for each operation.

In addition to "[Matters to Be Obeyed and Matters Prohibited](#)" (→ [Page 32](#)), these warnings present important information for each operation.



Types and Meanings of Warning Terms

■ Explanation of Presentation

"Warning labels" and "warning texts" in this Operation and Maintenance Manual warn you of the dangerous situations expected during operation in addition to the "warning terms" indicated with the categories mentioned below.

Disregarding the content of the warnings can result in accidents corresponding to the "warning" in the warning text. In extreme case, it to lead to a fatal accident, or damage to important parts of machinery and attached equipment, and can lead to environment damage outside the factory.



Table 1-1 Types and Meanings of Warning Terms

Types of warning terms	Meaning
 DANGER	Indicates an immediately hazardous situation which, if not avoided, will result in death or serious injury, serious failure or environmental destruction.
 WARNING	Indicates a potentially hazardous situation which, if not avoided, will result in death or serious injury, serious failure or environmental destruction.
 CAUTION	Indicates a potentially hazardous situation which, if not avoided, could result in minor or moderate injury.
Note	Indicates particularly a caution or information to be emphasized.

■ Meanings of Symbols

Cautions and presentation of danger are expressed using the following three kinds of symbols.

Table 1-2 Meanings of Symbols

Symbol	Meaning
 (Prohibition)	Indicates prohibition of a dangerous action.
 (General Instruction)	Indicates an operating instruction. In order to avoid a danger, it is necessary to take this action.
 (General Caution)	Indicates warning for a dangerous place and action, as well as a possibility that danger may occur due to carelessness, or negligence of safety duties.

Warning Labels

WARNING



Make sure that all warning/caution labels are legible. Clean or replace the warning/caution labels when the description and/or illustration are not clear to read.

- * Unreadable warning labels cannot be noticed and they may cause to personal injury, environmental pollution, and damage to engine.
- * For cleaning the warning labels, use a cloth, water and soap. Do not use cleaning solvents, gasoline or other chemicals to prevent damage to the print or peeling off of the label.
- * If any engine part on which a warning label is attached is replaced with a new one, purchase a new identical warning label from your MHIET dealer and attach it to the new part.

■ Precautions Concerning Handling

- (a) Keep in mind to understand the meanings of the warning labels thoroughly to conduct work on the engine more safely without causing any faults.
- (b) Never operate the engine until you understand the meanings of the warning labels thoroughly.
- (c) Always obey the detailed descriptions of the warning labels and the warning texts described in this Operation & Maintenance Manual to work on accordingly.
- (d) Do not tear or damage warning labels, nor wipe them with solvent.
- (e) Do not paint the warning labels when repainting the engine.
- (f) In case a warning label affixed to the engine becomes unreadable, damaged or peeled off, purchase a new label from your MHIET dealer "[CONTACT LIST](#)" (→ [Page 10](#)) and replace it.
- (g) After replacing an old part bearing a warning label with a new part, affix a new warning label in the same way as before.

■ Warning Labels and Their Locations (Examples)

Examples of locations of the warning labels are indicated on the next page.

Before using the engine, check the locations of the warning labels, since they differ according to the specifications of the devices and the construction work carried out by the generator suppliers.

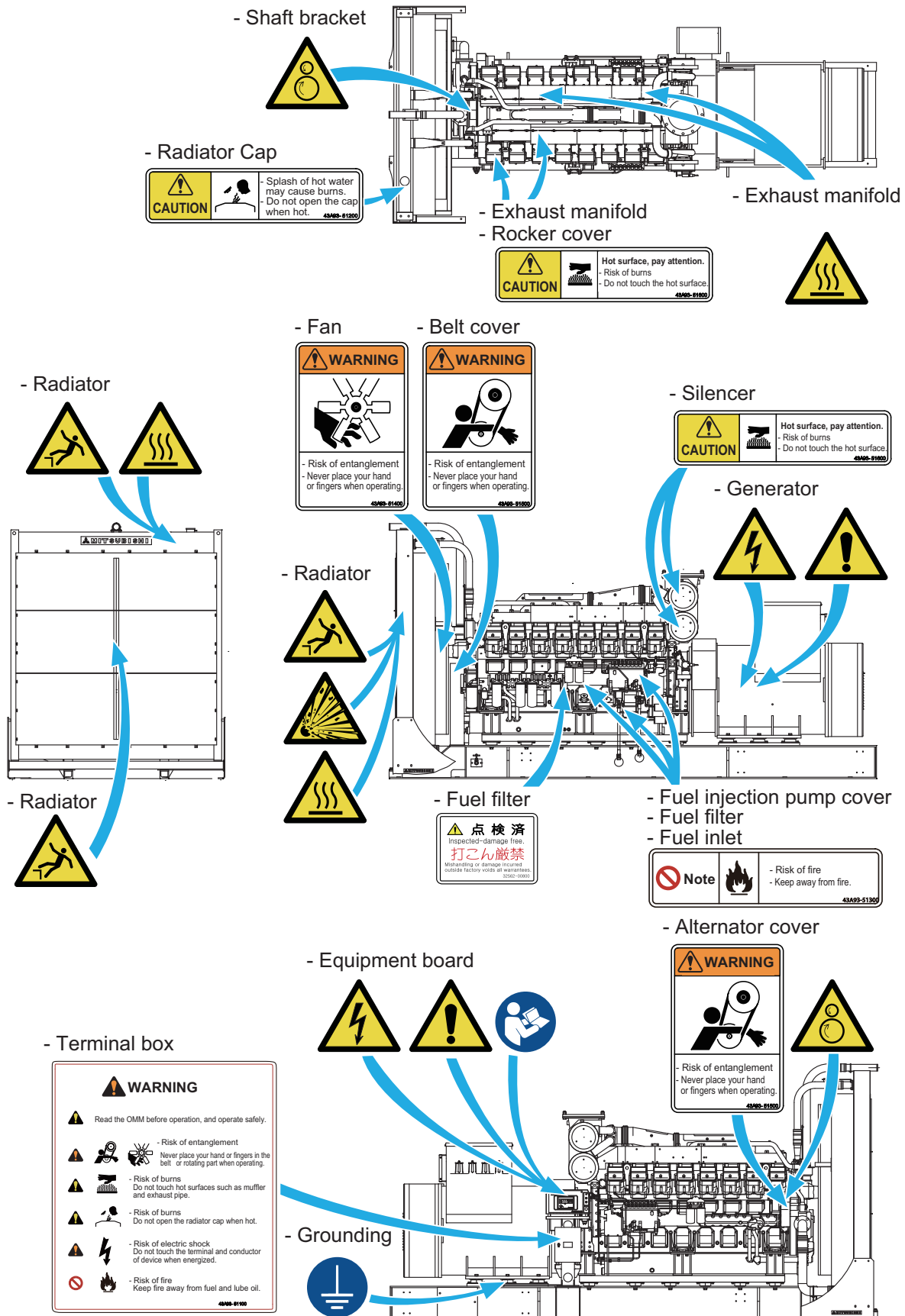

Fig. 1-1 Warning Labels and Their Locations (Examples)

Matters to Be Obeyed and Matters Prohibited

The matters to be obeyed and matters prohibited as described herein are intended to be guidelines for preventing personal injuries, accidents causing property damages, and environmental pollution. If these matters to be obeyed and matters prohibited are not obeyed, a serious injury to the operator, damage to the engine or environmental pollution could occur. Before handling the engine, be sure to understand the described details.

Safety Cautions

⚠ CAUTION



Do not operate the engine if you are not feeling well.

- * Operating the engine with reduced attentiveness could cause improper operation that could result in accidents or damage to the devices.



Be sure to obey the safety rules established at the workplace when operating, inspecting or maintaining the engine.

- * Operating the engine with reduced attentiveness could cause improper operation that could result in accidents or damage to the devices.

Preparation for Emergencies

⚠ WARNING



Prepare fire-fighting equipments and fire extinguishers. If you are obliged to prepare fire extinguishers by various laws and regulations, be sure to place them.

- * In case of a fire, delay in fire suppression will result in expansion of damage.
- * To extinguish engine fire, it is recommended to use an ABC dry-powder fire extinguisher which has the effect of suppressing of both of oil and electrical fires.

To extinguish the oil fire or an electrical fire, use an extinguisher suitable for the type of fire.

- * If you try to use water to extinguish the oil fire, the fire will get worse.
- * To extinguish engine fire, it is recommended to use an ABC dry-powder fire extinguisher which has the effect of suppressing of both of oil and electrical fires.

Prepare first-aid kits and first aid tools.

- * Otherwise, in case of personal injury, first aid treatment can be delayed, which may cause death in the worst case.

Prepare an emergency action plan in the event of emergency (fire, accidents, etc.) including emergency contact points and means of communication.

- * Delay in action will result in expansion of damage.

Precautions for Covers

WARNING

 **Do not attempt to open the side cover of the crankcase before the engine surface cools down to room temperature.**

* Opening the cover when the engine is hot allows fresh air to flow into the crankcase, which could cause oil mist to ignite and explode.

Do not remove the heat shields (laggings) from the intake and exhaust systems.

* If you touch it, you could get burned by heat.
* If any of these heat shields (laggings) have been removed to perform inspection and maintenance, be sure to install them after the work is completed.

 **When the engine is coupled to driven equipment, be sure to provide protective covers over the driving parts such as the connecting belts and couplings that are exposed.**

* Otherwise, belts and devices could fly apart and result in a serious personal injury.

Before starting the engine, make sure the protective covers of the engine are correctly installed.

* If you are caught in rotating parts, you could be seriously injured.

Precautions for Fire Sources

WARNING

 **Do not use flames near the engine.**

* They could cause a fire.

When working with flammable substances such as fuel, engine oil, coolant (LLC), grease, rust preventive oil, anti-corrosive agent, etc., use explosion-proof lighting equipment without fire.

* Otherwise, they could catch fire and cause an explosion.

Precautions Regarding the Environment

WARNING

 **Do not operate the engine in a poorly ventilated place.**

* Otherwise, it could cause carbon monoxide intoxication and lead to death at the worst.

 **Clean the engine and the surrounding area to remove dust, dirt and other foreign substances.**

* Otherwise, foreign objects could be caught in the engine, which could cause a fire or failure.

Precautions for Personal Protective Equipment

WARNING

 **When draining oil or replacing oil filters, be sure to wear working gloves.**

* Hot engine oil and parts could cause burns.

When working by using compressed air, wear protective glasses.

* Not wearing or not properly wearing personal protective equipment may result in serious personal injury.

Wear suitable personal protective equipment according to the workplace or the kind of work.

- **When operating, inspecting or maintaining the engine, wear a hard hat, a face shield, safety shoes, a dust mask, gloves, ear plugs and other personal protective equipment as needed.**

* Not wearing or not properly wearing personal protective equipment may result in serious personal injury.

CAUTION

 **Always wear ear plugs when entering the machine room (engine room).**

* Otherwise, noise could cause a hearing loss.

Precautions for Protection Devices

WARNING



Do not remove any circuits of the protection device.

* Otherwise, the protection device could not work in the event of an abnormality, which could cause personal injury or damage to the devices.



If a protection device activates, inspect the cause of the abnormality.

* If the cause cannot be determined, contact your MHIET dealer.

Precautions for Battery

WARNING



Do not use the battery when the battery fluid level is below the "LOWER LEVEL" mark.

- * Otherwise, degradation of the inner metal parts or lowering of the battery fluid level will be accelerated, which could cause an explosion or a fire.
- * Replace the battery with a new one.

Do not short the battery terminals with a tool or other metal objects.

- * A short circuit may cause explosion, fire, electric shock or fusing of the terminals.



When working with the battery, obey the manufacturer's operation manual or SDS.

- * If you accidentally swallow battery fluid, rinse your mouth with plenty of water and then drink lots of water, and seek immediate medical attention.

Remove water or debris on the top of the battery.

- * Otherwise, a short circuit may occur, which could cause a fire.

When disconnecting battery terminals, always remove the negative (-) terminal first. When connecting the battery, always connect the positive (+) terminal first.

- * Otherwise, a short circuit may occur, which could cause an electric shock or fusing of the terminals.

Charge the battery in a well-ventilated area.

- * Charging the battery in a poor ventilated area could let hydrogen gas accumulate, which could cause a fire.

Precautions for Warning Labels

WARNING



Make sure that all warning/caution labels are legible. Clean or replace the warning/caution labels when the description and/or illustration are not clear to read.

- * Unreadable warning labels cannot be noticed and they may cause to personal injury, environmental pollution, and damage to engine.
- * For cleaning the warning labels, use a cloth, water and soap. Do not use cleaning solvents, gasoline or other chemicals to prevent damage to the print or peeling off of the label.
- * If any engine part on which a warning label is attached is replaced with a new one, purchase a new identical warning label from your MHIET dealer and attach it to the new part.

Other Precautions

WARNING



Never cut the seal of the fuel control link.

- * If you cut the seal, damage to the engine or deterioration in the exhaust gas properties could occur.
- * In case that the seal is cut, warranty will become invalid.

Never peel off the label at the fuel inlet or other labels that are not allowed to remove.

- * Doing so may be against the law or regulations.

Precautions for Auxiliary Facilities of the Generator

■ Water Heater

WARNING



Do not touch the water heater even after stopping of the engine.

- * Even after stopping, water heater is at high temperature and touching it may cause burns.



For the generator with a water heater, connect the wiring of the water heater correctly.

- * Otherwise, flue explosion may occur, which could cause serious personal injury or damage to the devices.

For the generator with a water heater, always set the water heater switch to "ON".

- * If you start up the engine when the water heater switch is "OFF", incomplete combustion may occur, which could result in flue explosion or deterioration in the exhaust gas properties.

OPERATION

■ Daily Check

<Operational Environment - Check>

⚠ WARNING



Do not operate in an environment below the lower limit of the ambient temperature specified in the specifications sheet.

- * Otherwise, flue explosion may occur, which could cause serious personal injury or damage to the devices.
- * When operating in an environment below the lower limit of the ambient temperature, it is necessary to install an additional water heater.

Do not operate in an environment above the upper limit of the ambient temperature specified in the specifications sheet.

- * A violation of the law related to the devices could result.
- * Damage to the engine due to overheat or worsen exhaust values will result.
- * When operating in an environment above the upper limit of the ambient temperature, it is necessary to reexamine the operating conditions and operating time.

Keep away from fire, when working with flammable substances such as fuel, engine oil, coolant (LLC), grease, rust preventive oil and anti-corrosive agent.

- * They could cause a fire.

Do not place flammable substances such as fuel and engine oil around the engine.

- * They could cause a fire.



Make sure that there is no water (especially, seawater or rain water) seeped in the air intake and exhaust ports.

- * Piston scuffing (contact of the piston with the cylinder inner wall) and damage to the devices could result.

Make sure that no foreign particles get into the air inlet.

- * They could cause damage to the turbocharger and lead to serious problems in the engine.

⚠ WARNING



Make sure that there is no contamination of water into the fuel, engine oil, air inlet and exhaust systems and combustion chambers.

- * Flue explosion, deterioration in the exhaust gas properties or damage to the devices could result.

Make sure that there is no clogging in the air cleaner or pre-cleaner.

- * Otherwise, the engine stopping device will work to stop the engine suddenly and cause deterioration in the exhaust gas properties.

Make sure that there is no clogging in the air cleaner element or pre-cleaner element.

- * The thermal load could increase excessively and will cause piston scuffing.

Before maintaining electrical components, place the battery switch to the OFF position or disconnect the battery negative (-) terminal.

- * Electric shock could result when electricity flows through the circuit.

Be sure to operate the engine in an environment of appropriate humidity.

- * High humidity, inrush of rain water, or water condensation in the combustion chamber may cause falling off of valves or water hammering and lead to damage to the devices.

⚠ CAUTION



Before starting the engine, check that there are no bolts, nuts, tools, etc. around the rotating parts.

- * When the rotating parts work, the above objects can fly and cause personal injury or damage to the surrounding.
- * Entanglement in rotating parts could cause machine damage.

Check that the terminals and connectors of the electrical system are connected correctly.

- * Otherwise, starting failure or overrun due to inability to stop the engine could occur.

<Engine Exterior - Check>

⚠ WARNING

Make sure that any accumulation of flammables, fuel leaks, engine oil leaks, moisture, etc. are not found around the hot parts of the engine (exhaust manifold) and the battery.

* They could cause a fire.

Make sure that a coolant leak from any part of the engine is not found.

* Coolant will flow out.

Make sure that the open/close conditions of the valves, plugs and cocks on each line are normal.

* Otherwise, the engine may seize.

Make sure that the open/close condition of the coolant drain cock on the water pump is normal.

* Otherwise, insufficient cooling could occur and it could cause serious damage to the devices.

Make sure that the engine oil leak from any part of the engine is not found.

* If engine oil gets in your eyes, it will cause pain and lead to sight loss at the worst.

⚠ CAUTION

Before starting the engine, check the battery and cable terminals for corrosion. In addition, check the connections for looseness.

* Defective contact or short circuit could cause damage to the devices.

■ Pre-operation Check

⚠ WARNING

Be sure to perform the pre-operation check and scheduled maintenance as instructed in this Operation & Maintenance Manual.

* Failure to perform the pre-operation check and scheduled maintenance may cause various engine problems and breakage to parts, which may result in serious accidents.

Before starting the engine, make sure the protective covers of the engine are correctly installed.

* If you are caught in rotating parts, you could be seriously injured.

<Fuel Tank Oil Level - Check>

⚠ WARNING

When discarding a waste cloth used to wipe off combustible material, put it into a lidded can and obey the Waste Management and Public Cleansing Act to handle it as a special industrial waste.

* It may cause a fire.

* It could lead to environmental pollution.

* If you violate rules, you may be subject to penalties.

Before handling fuel, remove static electricity.

* Otherwise, the fuel could be ignited.

* Ground the fuel tank.

⚠ CAUTION

Do not remove the strainer while filling the fuel tank.

* Otherwise, foreign particles could enter and cause damage to the fuel pump.

<Coolant Level - Check>

⚠ DANGER

Use the genuine LLC specified in this Operation & Maintenance Manual.

* Otherwise, the devices could be damaged.

Keep LLC to be the specified concentration.

- * If LLC concentration is low, it could cause corrosion of the radiator or heat exchanger.
- * If LLC concentration is high, it may cause damage to the devices or overheat due to the seized engine parts.

⚠ WARNING

Do not open the radiator cap or coolant tank cap while the engine is hot.

* Otherwise, you could get burns by steam or water splashing out.



Tighten the drain cock on the water pump properly.

* Insufficient tightening may cause a coolant leak.

When handling coolant (LLC), always wear suitable personal protective equipment such as rubber gloves and protective eyeglasses.

- * If LLC comes into contact with your eyes, it will result in sight loss at the worst.
- * If LLC comes into contact with your skin while the engine is hot, you could get burned by heat.

Maintain the coolant level properly.

* If the coolant level is low, overheat or cavitation in the engine could occur.

<Battery - Check>

⚠ WARNING

Do not short the battery terminals.

* Otherwise, sparks could occur and cause a fire or an explosion.

Do not touch battery terminal with a wet hand.

* There are possibilities to get an electric shock.



When checking and servicing the battery, wear suitable personal protective equipment such as protective eyeglasses, rubber gloves, working clothes with long sleeves and long trousers.

* If battery fluid comes into contact with your eyes or skin, it may result in sight loss or burns.

<Pre-cleaner - Check for Clogging>

⚠ WARNING

Make sure that the pre-cleaner is free from clogging.

* Insufficient intake air could result in loss of power, incomplete combustion, exhaust gas temperature rise, and overspeed of the turbocharger.

<Air Cleaner - Check for Clogging>

⚠ WARNING

Make sure that the air cleaner is free from clogging.

* Insufficient intake air could result in loss of power, incomplete combustion, exhaust gas temperature rise, and overspeed of the turbocharger.

<Damper Temperature - Check>

⚠ WARNING

Make sure that the damper temperature is within the permissible range (for continuous use: 90°C [194°F] or less; for emergency use: 100°C [212°F] or less).

* Degradation of silicone oil could result in a loss of damping and breakage of the crankshaft.

<Manual Turning Gear - Check>

⚠ DANGER

Before starting the engine, pull out the manual turning gear shaft.

* Starting the engine while the turning gear is engaged with the ring gear could result in serious personal injury or destruction of the engine.

⚠ WARNING

Make sure that the plate of the manual turning gear is securely engaged in the shaft groove.

* Otherwise, the devices could be damaged.

<Air Direct Admission Starting - Check>

Starting Air Tank - Check

⚠ WARNING**Be sure to drain water from the starting air tank.**

* Otherwise, water could enter the cylinders when starting the engine.

<Air Motor Starting - Check>

Starting Air Tank - Check

⚠ WARNING**Make sure that the air pressure in the starting air tank satisfies the specification.**

* If starting is attempted several times in a row, the air motor could get damaged.

⚠ CAUTION**Be sure to drain water from the starting air tank.**

* Otherwise, water could enter the air motor when starting the engine.

■ Engine Start-up

⚠ WARNING**Do not apply load to the engine at startup.**

* Otherwise, the devices could be damaged.

Do not use the starter continuously for 10 seconds or longer. In case that the engine does not start after three consecutive trials, contact your MHIET dealer.

* Otherwise, flue explosion due to the accumulation of unburnt fuel or burn-damage to the starter may occur.

While a warning sign such as "DO NOT OPERATE" is hanged out on the starting system, do not start the engine.

* Otherwise, serious personal injury, environmental pollution or damage to the devices could occur.

Do not start the engine with water inside its combustion chamber.

* Otherwise, water hammering could cause damage to the engine inner parts and a serious accident.

**Before starting the engine, make sure there is no one in the vicinity of the engine.**

* Otherwise, he/she may be caught in the rotating parts and get seriously injured or suffer noise-induced hearing loss.

■ Warm-up Operation

WARNING



Stay away from rotating parts during operation.

- * Otherwise you may get caught in the rotating parts and seriously injured.

Do not apply excessive load when the engine is cold.

- * Otherwise, it could cause a failure.
- * If the engine is driven at an idle speed in the low load range for a prolonged period of time, unburnt fuel may accumulate in the flue and explode.



Allowable minimum load during continuous operation: Operate with 30% or more of the rated output. Allowable continuous operation time with a load factor of 30% or less of the rated output: Limit the operation within one hour.

Operate with a load factor of 50% or more for 30 minutes or more after continuous operation with 30% or less of the rated output is conducted.

The following problems may occur when light load operation is conducted beyond the above allowable range:

- * Fuel and/or oil leak from the exhaust system
- * Carbon build-up on the cylinder head and exhaust pipe
- * Sulfuric acid corrosion
- * Dilution
- * Generation of blue-white smoke (mainly during low idle operation)

While the engine is warming up, check the connections for leak (fuel, engine oil, coolant and exhaust gas). If an abnormality is found, stop the engine immediately.

- * Otherwise, a fire or damage to the devices may occur.
- * It could lead to carbon monoxide intoxication or environmental pollution.

■ Operation

WARNING



Stay away from rotating parts during operation.

- * Otherwise you may get caught in the rotating parts and seriously injured.

Do not approach the engine side without care during operation.

- * Serious injury may result due to unexpected device operation.

Do not touch any part of the engine (other than the manual stop lever) during or immediately after operation and immediately after stopping.

- * If you touch, you could get burned by heat.
- * Before starting the inspection and maintenance work, make sure that the engine is cooled down.

Do not turn off the battery switch during operation.

- * Otherwise, the instruments will become inoperable, damage to the devices due to operation at low oil pressure may occur, the engine may be forcibly stopped by the solenoids, or the engine may become unable to stop.
- * It may also cause degradation of the diodes and transistors in the alternator.

Never turn the key to the "START" position during operation.

- * Otherwise, the starter could be damaged.

Do not remove the protective covers during operation.

- * If you are caught in rotating parts, you could be seriously injured.

Do not perform the inspection and maintenance work during operation.

- * Unexpected activation of the devices could cause serious personal injury or damage to the devices.

Do not clean the engine during operation.

- * Otherwise, water or cleaning solution could enter the engine, and will cause piston scuffing and damage to the devices.

Do not operate the engine at no load or low load for a prolonged period of time.

- * Otherwise, it could cause deterioration in the exhaust gas properties.

⚠ WARNING

Do not operate the engine at a load exceeding the specified value or for a prolonged period of time.

- * Otherwise, the main bearing or connecting rod bearing could seize.
- * The thermal load could increase excessively and will cause piston scuffing.
- * Otherwise, the crankshaft stress could become too large, and the crankshaft could crack or break.

Do not approach near the breather or breather gas.

- * The breather releases breather gas in the air. Contacting the breather gas may cause burns.



Ventilate the machine room (engine room) sufficiently.

- * Otherwise, deterioration in the exhaust gas properties and damage to the devices could occur due to insufficient air intake.

Allowable minimum load during continuous operation: Operate with 30% or more of the rated output. Allowable continuous operation time with a load factor of 30% or less of the rated output: Limit the operation within one hour.

Operate with a load factor of 50% or more for 30 minutes or more after continuous operation with 30% or less of the rated output is conducted.

The following problems may occur when light load operation is conducted beyond the above allowable range:

- * Fuel and/or oil leak from the exhaust system
- * Carbon build-up on the cylinder head and exhaust pipe
- * Sulfuric acid corrosion
- * Dilution
- * Generation of blue-white smoke (mainly during low idle operation)

<Checking during Operation>

⚠ WARNING

If an engine abnormality is observed during operation, stop the engine immediately.

- * Use of the engine without any remedy could cause serious personal injury or damage to the devices.
- * Investigate the cause of abnormality, correct the defect, then restart the engine.
- * If the cause of problem cannot be located, contact your MHIET dealer.

If overload symptoms such as black exhaust smoke is observed, reduce the load immediately and assure the proper output.

- * Overload could not only cause increase in fuel consumption but also lead to malfunction and environmental pollution (outbreak of the black smoke) due to carbon deposits.

Check exhaust pipes and pipe joints for exhaust gas leaks.

- * Otherwise, it may cause carbon monoxide intoxication and lead to death at the worst.
- * If an exhaust leak is found, contact your MHIET dealer.

If an abnormal engine oil pressure drop is observed, stop the engine immediately, and check the engine oil system to locate the cause.

- * Use of the engine without any remedy could cause seizure of the bearings and lead to serious damage to the devices.
- * If the cause of problem cannot be located, contact your MHIET dealer.

If a belt breaks, stop the engine immediately and replace the belt.

- * Use of the engine without any remedy could cause defective battery charge and cooling fault, and result in serious engine problems.

CAUTION**Keep the intake air temperature at the specified level.**

- * If the intake air temperature is higher than the specified level, the engine stopping device may work due to the increased exhaust temperature and stop the engine suddenly.
- * The thermal load could increase excessively and will cause piston scuffing.
- * If the intake air temperature cannot be kept at the specified level, reconsider the operating conditions and operating time.

Keep the engine oil and coolant temperatures at the specified level.

- * If the engine oil or coolant temperatures is increased, the engine stopping device may work due to the increased exhaust temperature and stop the engine suddenly.

■ Cooling Operation**WARNING****Except in a time of emergency, operate the engine at low idle for 5 to 6 minutes to cool down before stopping the engine.**

- * If the engine is stopped without cooling down, the devices could be damaged.

CAUTION**Do not stop the engine suddenly at high speed.**

- * It could cause damage to the devices due to degradation of the damper or stopped circulation of the engine oil to the turbocharger.

■ Stopping**WARNING****Do not restart the engine immediately after an abnormal stop.**

- * Investigate the cause of abnormality, correct the defect, then restart the engine.

Do not race the engine immediately before shutting it down.

- * Otherwise, the devices could be damaged.

FUEL**■ Fuel****WARNING****Do not refill the fuel tank more than the specified level.**

- * Otherwise, fuel will leak out and may cause a fire.

Do not mix and use fuels of different types and/or manufacturers.

- * Otherwise, damage to the fuel supply pump or deterioration in the exhaust gas properties may occur.

Do not use fuel after the recommended storage expiration date.

- * Otherwise, incomplete combustion may occur, which could result in flue explosion or deterioration in the exhaust gas properties.

**Use only the fuel that meets our fuel quality standards specified in this Operation & Maintenance Manual.**

- * Otherwise, damage to the fuel supply pump or deterioration in the exhaust gas properties may occur.
- * Using a fuel with low cetane number (lower than 45) may result in flue explosion.

Change the fuel remained in the tank or the pipelines over the period recommended by the manufacturer with new fuel.

- * Otherwise, deterioration in the components may cause clogged pipe lines, which could result in starting failure.

■ Diesel Fuel (Emission Control Approved Model)

⚠ WARNING

 **Do not mix any poor-quality fuel, water extracting agent, fuel additive, gasoline, kerosine, or alcohol-based fuel.**

* It could cause fuel filter clogging, sliding fault on the fuel lubricated part in fuel injector, and adverse effect to the engine, and will lead to an engine trouble.

 **Be sure to use Ultra-Low-Sulfur Diesel (ULSD) for the emission control approved model engine.**

* If not used, there is a risk that the engine cannot conform to the emission control regulation of Environmental Protection Agency (EPA) of United States.

■ Fuel - Handling

⚠ WARNING

 **Do not discard waste oil into sewerage, river, lake or other similar places.**

* Be sure to discard waste oil in accordance with the applicable laws and regulations.

Do not store fuel in a poorly ventilated place.

* Otherwise, vaporized fuel may build up, which could cause an explosion or a fire on exposure to a flame.

 **Before handling fuel, remove static electricity.**

* Otherwise, the fuel could be ignited.

* Ground the fuel tank.

When working with fuel, wear suitable personal protective equipment such as protective mask, protective eyeglasses, rubber gloves, working clothes with long sleeves and long trousers.

* If fuel comes into contact with your eyes, mouth or skin, it will cause irritation or disorders.

Do not breathe in vaporized fuel.

* Otherwise, it could be hazardous to your health.

When storing fuel in the container, close its cap tightly.

* Otherwise, vaporized fuel may build up, which could cause an explosion or a fire on exposure to a flame.

<Fuel - Refill>

⚠ WARNING

 **Be sure to drain water from fuel, and pay attention that coolant or other water will not get mixed with fuel.**

* Otherwise, rust could form on the plunger, which could interfere engine stopping or cause flue explosion, dilution, or water hammering.

⚠ CAUTION

 **Do not remove the strainer while filling the fuel tank.**

* Otherwise, foreign particles could enter and cause damage to the fuel pump.

 **When using fuel from a storage tank, leave it to sit for more than 24 hours so that dust and water can settle at the bottom. Then, use the upper clean fuel.**

* Otherwise, clogging of the filter may occur, which could cause decrease in the output power.

* Depending on the specification of the tank, prolonged sedimentation time may be required.

ENGINE OIL

■ Engine Oil

WARNING



Refer to the Engine Oil Properties table in this Operation & Maintenance Manual, and even if one item exceeds the limit, the engine oil must not be used.

* Otherwise, seizure of the sliding parts may occur, which could cause serious damage to the devices.



Use the genuine engine oil specified in this Operation & Maintenance Manual.

* Otherwise, seizure of bearings, breakage of a valve, sticking of a piston ring, seizure between a ring and a cylinder, premature wear of bearings and sliding parts may occur, which could shorten the service life of the engine.

Conduct analysis of the engine oil periodically and check to make sure that the engine oil does not show milky color.

* If the engine oil shows milky color, water may be mixed into the engine oil system due to coolant leak or a damaged cylinder liner O-ring. Use of the engine without any remedy could cause seizure of the crankshaft and lead to serious damage to the devices.

Keep the quantity and properties (viscosity) of the engine oil at the specified level.

* If the supply or kinematic viscosity of engine oil is too low, insufficient lubrication of the bearing could occur, which could cause seizure of the crankshaft.

* If kinematic viscosity of engine oil increases, fuel consumption will increase.

■ Handling Engine Oil

WARNING



Keep away from fire, when working with flammable substances such as engine oil.

* They may cause a fire.

Do not operate the engine with fuel or water mixed in the engine oil.

* Otherwise, viscosity of engine oil could decrease, which could cause seizure of the bearings or other serious accidents.

Do not store engine oil in a poorly ventilated place.

* Otherwise, vaporized engine oil may build up, which could cause an explosion or a fire on exposure to a flame.



Wipe off spilled flammable substances such as engine oil thoroughly with a waste cloth.

* They may cause a fire.

When discarding a waste cloth used to wipe off combustible material, put it into a lidded can and obey the Waste Management and Public Cleansing Act to handle it as a special industrial waste.

* It may cause a fire.

* It could lead to environmental pollution.

* If you violate rules, you may be subject to penalties.

When handling engine oil, obey the manufacturer's SDS.

* If engine oil gets in your eyes, it will cause pain and lead to sight loss at the worst.

Do not breathe in vaporized engine oil.

* Otherwise, it could be hazardous to your health.

When storing engine oil in the container, be sure to close the cap.

* Otherwise, vaporized engine oil may build up, which could cause an explosion or a fire on exposure to a flame.

COOLANT

■ Water to Be Used

⚠ WARNING



When you add water to coolant, use only the water that meets the water quality standard specified in this Operation & Maintenance Manual.

* Otherwise, premature corrosion or overheating in the engine parts may occur.

■ LLC to Be Used

⚠ DANGER



Use the genuine LLC specified in this Operation & Maintenance Manual.

* Otherwise, the devices could be damaged.

■ Coolant (LLC) - Handling

⚠ WARNING



Keep away from fire, when working with flammable substances such as coolant (LLC).

* They may cause a fire.



Wipe off spilled flammable substances such as coolant (LLC) thoroughly with a waste cloth.

* They may cause a fire.

When discarding a waste cloth used to wipe off combustible material, put it into a lidded can and obey the Waste Management and Public Cleansing Act to handle it as a special industrial waste.

* It may cause a fire.

* It could lead to environmental pollution.

* If you violate rules, you may be subject to penalties.

Use care not to let oil mixed with coolant.

* Otherwise, cooling failure could occur, which could cause overheating.

⚠ WARNING



When handling coolant (LLC), always wear suitable personal protective equipment such as rubber gloves and protective eyeglasses.

* If LLC comes into contact with your eyes, it will result in sight loss at the worst.

* If LLC comes into contact with your skin while the engine is hot, you could get burned by heat.

■ Maintenance of LLC

<Replacement Period>

⚠ DANGER



Do not use LLC after the recommended storage expiration date.

* Otherwise, the devices could be damaged.

■ LLC Concentration

⚠ DANGER



Keep LLC to be the specified concentration.

* If LLC concentration is low, it could cause corrosion of the radiator or heat exchanger.

* If LLC concentration is high, it may cause damage to the devices or overheat due to the seized engine parts.

SCHEDULED MAINTENANCE

⚠ WARNING



Do not take actions for items indicated as "Contact your MHIET dealer" in the measure column in the Scheduled Maintenance.

* Otherwise, serious accident, environmental pollution or damage to the devices may occur. Be sure to contact your MHIET dealer.



Be sure to perform the pre-operation check and scheduled maintenance as instructed in this Operation & Maintenance Manual.

* Failure to perform the pre-operation check and scheduled maintenance may cause various engine problems and breakage to parts, which may result in serious accidents.

INSPECTION AND MAINTENANCE

■ Precautions for General Inspection and Maintenance

⚠ DANGER



Before starting the engine, pull out the manual turning gear shaft.

- * Starting the engine while the turning gear is engaged with the ring gear could result in serious personal injury or destruction of the engine.

Before inspecting and maintaining the engine, read this Operation & Maintenance Manual thoroughly to understand the construction and the required work to service the corresponding part. In addition, conduct the work after fully studying the procedure.

- * In case of conducting the work without studying enough, an accident or damage due to wrong installation, or deterioration in the exhaust gas properties may occur.

⚠ WARNING



Do not make any modifications to the engine without our previous written agreement.

- * Otherwise, damage to the devices or significant environmental pollution may occur.
- * In such a case, the whole warranty will become invalid.

Do not work while standing on the engine.

- * Otherwise, you may slip and fall by accident, and get injured.
- * In addition, the devices or pipes may be damaged.

Do not disconnect the fuel or engine oil piping while the engine is operating or at high temperature.

- * Otherwise, fuel could come in contact with the engine, which could cause a fire.

Do not disconnect the pipes immediately after the engine is stopped.

- * Otherwise, you could get burned by hot engine oil or coolant splashing out.

⚠ WARNING



Do not touch any part of the engine (other than the manual stop lever) during or immediately after operation and immediately after stopping.

- * If you touch, you could get burned by heat.
- * Before starting the inspection and maintenance work, make sure that the engine is cooled down.



Only the genuine parts are recommended to use.

- * Using non-genuine parts could cause deterioration in the exhaust gas properties and damage to the devices.
- * Failures or damages caused by using non-genuine parts will be outside the scope of the warranty.

While washing the engine, pay attention that water or foreign particles will not enter the engine.

- * Otherwise, the devices could be damaged.

After washing the engine, blow off water around the terminals by using compressed air.

- * Otherwise, it may cause damage to the devices due to short circuit.

Before maintaining electrical components, place the battery switch to the OFF position or disconnect the battery negative (-) terminal.

- * Electric shock could result when electricity flows through the circuit.

Wipe off spilled flammable substances such as fuel, engine oil, coolant (LLC), grease, rust preventive oil and anti-corrosive agent.

- * They may cause a fire.

When discarding a waste cloth used to wipe off combustible material, put it into a lidded can and obey the Waste Management and Public Cleansing Act to handle it as a special industrial waste.

- * It may cause a fire.
- * It could lead to environmental pollution.
- * If you violate rules, you may be subject to penalties.

⚠ WARNING

Make sure that dripped oil, parts, tools or other things are not left on the floor around the engine. Always maintain cleanliness and tidiness.

- * Otherwise, a tumbling accident may occur.
- * Wear proper personal protective equipment for the work.

Watch your step during inspection and maintenance work.

- * Otherwise, a tumbling accident or a falling accident may occur while working on the floor panel or other high positions.
- * The floor could be extremely slippery due to spilt oil. Thoroughly wipe off oil on the floor and the sole of your shoes.
- * Install a stable scaffold as required.

Cover the disconnected pipes or joints and their openings properly so that dusts or other foreign objects will not enter into them.

- * Otherwise, the devices may be damaged.

The engine must be inspected and maintained only by qualified persons who have received a required training or on-site instructions, or done so under the mentorship of a person who have completed our training course.

- * Otherwise, serious personal injury or damage to the devices may occur.

When working on the upper part of the engine and other hard-to-reach places, use a stable work platform.

- * Do not stand on an old stool or parts box. Otherwise, it may result in personal injury. In addition, do not put any unnecessary objects on a work platform.

⚠ CAUTION

While inspecting and maintaining, do not put your hand in a gap between the connecting rod, crankshaft, timing gear or others and the crankcase.

- * Otherwise, you may be stuck and injured.

While operating the engine, stay away from the moving parts.

- * Otherwise, you may cut your hand by the rotating parts, or be caught in them and injured.

■ Inspection and Maintenance - Prepare

⚠ WARNING

Make sure that the tools to be used are not damaged.

- * Using a damaged tool or a wrong-size tool may cause personal injury or damage to the devices.

Check and calibrate measurement equipment periodically.

- * Using uncalibrated measurement equipment may cause damage to the devices or performance degradation of them.

<Inspection and Maintenance - Prepare (with Engine Switched OFF)>

⚠ WARNING

Be sure to lockout/tagout before starting inspection and maintenance work.

- * Unexpected startup of the engine could cause serious personal injury or damage to the devices.

Be sure to establish zero energy state before starting inspection and maintenance work.

- * Unexpected activation of the devices could cause serious personal injury or damage to the devices.

■ Engine Body - Check

<Belt -Check>

⚠ WARNING

Stay away from rotating parts during operation.

- * Otherwise you may get caught in the rotating parts and seriously injured.

⚠ CAUTION

Keep the belt for the crankshaft pulley or alternator free from oil and grease.

- * Otherwise, a slip could occur, which will shorten the service life of the belt.

⚠ CAUTION

Check each belt status (tension, damage and the like) of the crankshaft pulley or alternator.

* If the belt has been stretched, the battery cannot be charged and DC power supply will be lost.

<Belt Tension (Alternator) - Adjust>

⚠ WARNING

Stay away from rotating parts during operation.

* Otherwise you may get caught in the rotating parts and seriously injured.



Adjust the belt tension properly in accordance with the procedures recommended by MHIET.

* Otherwise, the service life of the alternator, bearing or belt could be shortened.
* After you replaced the belt with a new one, check the tension again after the initial stretch of the belt is settled.

⚠ CAUTION

Keep the belt for the crankshaft pulley or alternator free from oil and grease.

* Otherwise, a slip could occur, which will shorten the service life of the belt.

<Damper - Check>

⚠ WARNING

Install a protective cover which can dissipate heat.

* Otherwise, the damper could be enclosed and degenerated due to poor heat dissipation and ventilation, and which may cause breakage of the crankshaft.

■ Fuel System - Check**⚠ WARNING**

Keep away from fire, when working with flammable substances such as fuel.

* They may cause a fire.

If fuel leaks or splashes out from the high pressure injection pipe, do not touch the fuel.

* The fuel injection pipe delivers high pressure fuel. If the fuel contacts your skin, it goes into deep skin tissues and may result in gangrene.



Wipe off spilled flammable substances such as fuel thoroughly with a waste cloth.

* They may cause a fire.

When discarding a waste cloth used to wipe off combustible material, put it into a lidded can and obey the Waste Management and Public Cleansing Act to handle it as a special industrial waste.

* It may cause a fire.

* It could lead to environmental pollution.

* If you violate rules, you may be subject to penalties.

<Fuel Tank -Check and Service>

Fuel Tank - Clean

⚠ WARNING

Tighten the fuel supply valve to the engine firmly.

* Otherwise, fuel may leak out, which could cause a fire.

⚠ CAUTION

After cleaning the fuel tank, do not leave the used waste cloth in the fuel tank.

* Otherwise, it may cause damage to the devices in the fuel system.



When draining fuel through the drain cock, always use a container which can accept all the fuel in the tank.

* Otherwise, the drained fuel will overflow from the container and may run to outside of the facility.

* The fuel drained into the container shall be discarded in accordance with the local laws and regulations as well as the manufacturer's SDS.

Fuel Tank - Drain Water

CAUTION

! When draining water from the fuel tank, always use a container which is suitable for the water quantity.

- * Otherwise, the drained water will overflow from the container and may run to outside of the facility.
- * The water drained into the container is contaminated with fuel. Discard the water in accordance with the local laws and regulations as well as the manufacturer's SDS.

Drain water properly from the fuel tank.

- * If water, dust or other foreign particles are left, they may mix with fuel, which could cause low output power or damage to the devices in the fuel system.

< Fuel System - Bleed Air >

WARNING

! Bleed air sufficiently from the fuel system.

- * Otherwise, starting failure may occur.

After bleeding, tighten the priming pump firmly.

- * If the tightening torque is too weak, fuel leak may occur.
- * If the tightening torque is too strong, the priming pump could be damaged.

<Water Separator - Check and Service>

Water Separator - Drain Water

CAUTION

! When draining water from the water separator, always use a container which is suitable for the water quantity.

- * Otherwise, the drained water will overflow from the container and may run to outside of the facility.
- * The water drained into the container is contaminated with waste oil. Discard the water in accordance with the local laws and regulations as well as the manufacturer's SDS.

Drain water properly from the water separator.

- * If draining the water separator is insufficient, water may enter into the fuel system, which could cause damage to the devices.

Water Separator Element - Replace

WARNING

! Open the inlet valve of the water separator slowly to prevent fuel in the water separator from spilling out. Wrap a cloth around the water separator.

- * Otherwise, spilled fuel may be ignited, which could cause a fire.

CAUTION

! Tighten the cover and cock on the water separator appropriately.

- * If the tightening torque is too weak, fuel may leak, causing a fire or fuel flow-out, which could lead to environmental pollution.

<Gauze Filter - Clean>

WARNING

! Clean the gauze filter properly.

- * A clogged gauze filter may result in insufficient fuel supply, low power output, or engine stall during operation.

CAUTION

! When replacing the gauze filter, tighten the new one under the same condition as the old one was installed.

- * If the tightening torque is too weak, fuel may leak, causing a fire or fuel flow-out, which could lead to environmental pollution.

<Fuel Filter - Replace>

WARNING

⊘ Do not pour fuel into the fuel filter before installing it.

- * Otherwise, it may cause serious personal injury, environmental pollution due to fuel running to outside of the facility, or damage to the devices.
- * Follow the installation procedure described in this Operation & Maintenance Manual.

! Use a genuine fuel filter.

- * If a non-genuine filter is used, deterioration in the exhaust gas properties and damage to the devices could occur due to insufficient air intake.
- * Failures or damages caused by using non-genuine parts will be outside the scope of the warranty.

CAUTION

Do not use a fuel filter with a scratch or dent.

* Otherwise, damage to the filter or fuel leak may occur, which could cause a fire or environmental pollution due to fuel running to outside of the facility.

Do not use a filter wrench when installing the fuel filter.

* It may cause a dent or damage to the fuel filter.



If fuel spills out while removing the fuel filter, wipe off with a waste cloth.

* Otherwise, it may cause a fire or environmental pollution due to fuel running to outside of the facility.

* The waste cloth used to wipe off fuel shall be discarded in according with the local laws and regulations as well as the manufacturer's SDS.

Check the specification of the fuel filter when installing it.

* The fuel filter of which specification does not apply to the fuel may cause damage to the devices.

<Fuel Control Link - Check>

WARNING

Never cut the seal of the fuel control link.

* If you cut the seal, damage to the engine or deterioration in the exhaust gas properties could occur.

* In case that the seal is cut, warranty will become invalid.



Make sure there is no looseness or play at the fuel control link.

* Otherwise, the engine may overrun.

CAUTION

When checking the fuel control link, do not insert your finger into the moving parts.

* Otherwise, you may get injured.

<Fuel Pipe - Check>

WARNING

Check the clamp for the high pressure fuel injection pipe for looseness.

* If looseness or play is detected at the clamp for the high pressure fuel injection pipe, damage to the pipe may occur, which could cause a fire.

Install the clamp for the high pressure fuel injection pipe at the correct position.

* If it is installed at a wrong position, the pipe could be damaged, which could cause a fire.

■ Engine Oil System - Check

WARNING

Do not touch hot engine oil or parts.

* Otherwise, you could get burned.

Do not discard waste oil into sewerage, river, lake or other similar places.

* Be sure to discard waste oil in accordance with the applicable laws and regulations.

<Engine Oil - Change>

Engine Oil - Check

WARNING

Conduct analysis of the engine oil periodically and check to make sure that the engine oil does not show milky color.

* If the engine oil shows milky color, water may be mixed into the engine oil system due to coolant leak or a damaged cylinder liner O-ring. Use of the engine without any remedy could cause seizure of the crankshaft and lead to serious damage to the devices.

Engine Oil - Refill

⚠ WARNING

Be sure to install the oil filler cap after engine oil is refilled.

- * Otherwise, seizure due to insufficient oil or environmental pollution due to engine oil running out from the facility may occur.

Make sure that engine oil is not leaking from the oil pan. When checking the engine oil level, wear protective glasses to prevent engine oil from getting in your eyes.

- * If engine oil gets in your eyes, it will cause pain and lead to sight loss at the worst.

Refill engine oil enough to raise the level to within the specified range (between the highest line {H} and the lowest line {L}).

- * If the engine oil level exceeds the upper limit, the oil pan may crack or oil may splash out from the breather.
- * If the engine oil level is too low, seizure of the bearings could occur.

Keep the quantity and properties (viscosity) of the engine oil at the specified level.

- * If the supply or kinematic viscosity of engine oil is too low, insufficient lubrication of the bearing could occur, which could cause seizure of the crankshaft.
- * If kinematic viscosity of engine oil increases, fuel consumption will increase.

Engine Oil Level - Check

⚠ WARNING

Keep away from fire, when checking the engine oil level.

- * It may cause a fire.

<Oil Filter - Replace>

⚠ WARNING

When replacing the oil filter, do not pour the remaining engine oil in the old filter into the new filter.

- * Otherwise, foreign particles could enter the engine oil system, which could cause damage to the devices.



Before replacing the oil filter, make sure that the engine has cooled down to the normal temperature.

- * Otherwise, you could get burned by heat.

Use a genuine oil filter.

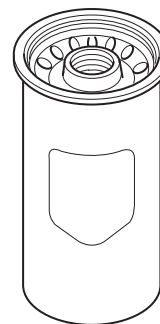

- * Using non-genuine parts could cause damage to the devices or degradation in the performance.
- * Failures or damages caused by using non-genuine parts will be outside the scope of the warranty.

If paint or other matter is adhering around the sealing surface, remove them before assembling.

- * If paint or other matter is stuck on the sealing surface, fuel could leak through the gap, which could cause a fire.

If engine oil spills out while removing the oil filter, wipe off with a waste cloth.

- * Otherwise, it may cause a fire or environmental pollution due to fuel running to outside of the facility.
- * The waste cloth used to wipe off engine oil shall be discarded in according with the local laws and regulations as well as the manufacturer's SDS.

⚠ CAUTION

Do not use the oil filter with a scratch or dent.

* Otherwise, damage to the filter or oil leak may occur, which could cause a fire or environmental pollution due to fuel running to outside of the facility.

Do not use a filter wrench when installing the oil filter.

* It may cause a dent or damage to the oil filter.



When replacing the oil filter, set the gasket into the groove properly.

* Otherwise, engine oil leak could occur, which could cause a fire or environmental pollution due to oil running to outside of the facility.

* Follow the replacing procedure described in this Operation & Maintenance Manual.

<Governor Oil Filter - Replace (Hydraulic Governor Spec)>

⚠ WARNING

Do not touch hot engine oil or parts.

* Otherwise, you could get burned.

■ Cooling System - Check

⚠ WARNING

Do not continue to operate the engine with engine oil mixed in coolant.

* Otherwise, cooling failure may occur, which could cause damage to the engine.

Do not open the radiator cap or coolant tank cap while the engine is hot.

* Otherwise, you could get burns by steam or water splashing out.



Tighten the drain cock on the water pump properly.

* Insufficient tightening may cause a coolant leak.

⚠ CAUTION

Follow the coolant draining procedure described in this Operation & Maintenance Manual.

* Draining in the incorrect procedure may cause burns or environmental pollution due to coolant running to outside of the facility.

When handling cleaning solution for washing the cooling system, obey the manufacturer's SDS.

* Improper wearing or using of personal protective equipment may cause personal injury.

<Cooling System - Clean>

⚠ CAUTION

When handling cleaning solution for washing the cooling system, obey the manufacturer's SDS.

* Improper wearing or using of personal protective equipment may cause personal injury.

<Cooling System - Bleed Air>

⚠ WARNING

Bleed air sufficiently from the cooling system.

* If air remains in the coolant, cooling performance may degrade, and seizure of the engine or piston scuffing may occur.

<Radiator Fins - Check and Clean (Radiator Specification)>

⚠ WARNING

When working by using compressed air, wear protective glasses.

* Not wearing or not properly wearing personal protective equipment may result in serious personal injury.

Check the radiator fins for holes and cracks.

* Otherwise, overheating, damage to the devices, or performance degradation may occur.

<Resin Fan Inspection (Specifications with Resin Fan)>

Blade Inspection

⚠ WARNING



Check that there are no flaws, cracks or discoloration on the surface of blades.

- * If you operate the engine with a defective blade, the blade may break.

Check that there is no play in the blade mounting portion.

- * If there is play in the blade mounting portion, the blades may be abnormally worn.

Check that there is no looseness in the blade mounting portion.

- * If there is looseness in the blade mounting portion, the blades may break.

Since replacing a blade requires balancing, do not replace a single blade by yourself.

- * When replacing a single blade, be sure to ask MHIET dealer.

Blade Cleaning

⚠ WARNING



When cleaning the blades, do not use acid and alkaline solutions.

- * There is a risk of blade deterioration.

Do not use a high-pressure washer to clean the blades.

- * There is a risk of blade deterioration.



Before operating the engine, make sure that the surfaces of blades have dried.

- * Operating the engine with the blades wet may cause deterioration of the blade.

■ Intake and Exhaust Systems - Check

<Turbocharger - Check>

⚠ WARNING



Before checking the turbocharger, make sure that the engine has cooled down to normal temperature. Before checking, make sure that the compressor wheel is not rotating.

- * Otherwise, you could get burned.
- * If you are caught in a rotating compressor wheel, you will suffer laceration.



Make sure that there is no intake air leak in the piping to the compressor of the turbocharger.

- * If there is intake air leak, insufficient boost pressure could occur, which could cause deterioration in the exhaust gas properties.

⚠ CAUTION



Check that the compressor or turbine of the turbocharger is not dirty.

- * If the compressor or turbine of the turbocharger is dirty, performance degradation of the turbocharger may occur, which could cause power reduction.

<Exhaust Muffler - Drain Water>

⚠ WARNING



Do not touch the exhaust muffler immediately after the engine is stopped.

- Make sure that the engine is cooled down to the normal temperature.
- * Otherwise, you could get burned.

<Pre-cleaner - Check and Service>

⚠ WARNING



Do not check, maintain or remove the pre-cleaner during operation.

- * Otherwise, dust or other foreign particles may enter the engine, which could accelerate wear of the parts or cause damage to the devices including the turbocharger.



Take care that parts will not fall down and get caught in the fuel control link.

- * If parts are caught in the fuel control rack, the engine will become out of control.

<Pre-cleaner - Check for Clogging

⚠ WARNING

Make sure that the pre-cleaner is free from clogging.

* Insufficient intake air could result in loss of power, incomplete combustion, exhaust gas temperature rise, and overspeed of the turbocharger.

<Air Cleaner - Check and Service>

Air Cleaner - Check for Clogging

⚠ WARNING

Make sure that the air cleaner is free from clogging.

* Insufficient intake air could result in loss of power, incomplete combustion, exhaust gas temperature rise, and overspeed of the turbocharger.

■ Electrical System - Check

<Battery - Check>

⚠ WARNING

Do not short the battery terminals.

* Otherwise, sparks could occur and cause a fire or an explosion.

Do not touch battery terminal with a wet hand.

* There are possibilities to get an electric shock.



When checking and servicing the battery, wear suitable personal protective equipment such as protective eyeglasses, rubber gloves, working clothes with long sleeves and long trousers.

* If battery fluid comes into contact with your eyes or skin, it may result in sight loss or burns.

<Starter - Check (Self Starter Motor Starting)>

⚠ CAUTION

Check that there is no damage to the pinion gear of the starter.

* Otherwise, a spark or damage to the devices could occur.

<Alternator - Check>

⚠ CAUTION

Do not touch the rotating part of the alternator.

* Otherwise, you may get caught in the rotating part and suffer an injury or damage to the devices could occur.

■ Air Direct Admission Starting, Air Motor Starting - Check

<Air Strainer - Drain Water and Clean>

⚠ WARNING

When working by using compressed air, wear protective glasses.

* Not wearing or not properly wearing personal protective equipment may result in serious personal injury.

⚠ CAUTION

Before draining or cleaning the starting air strainer, bleed air completely. In addition, check the pressure reduction with the pressure gauge.

* If high pressure air remains in the pipe, the drain valve may blow off, which could cause personal injury or damage to the devices.

<Starting Air Tank - Check and Service>

⚠ WARNING

Be sure to drain water from the starting air tank.

* Otherwise, water could enter the cylinders when starting the engine.

Make sure that the safety valve on the starting air tank is not malfunctioning.

* If the safety valve is out of order, improper operation could occur, which could result in explosion of the starting air tank.

⚠ CAUTION

Be sure to drain water from the starting air tank.

* Otherwise, water could enter the air motor when starting the engine.

LONG-TERM STORAGE

■ Storing Engine in Inoperable Condition

<Storage - Prepare (Rust-preventive Measure)>

⚠ WARNING

⊘ Keep away from fire, when working with flammable substances such as volatile corrosion inhibitor or rust preventive oil.

* They may cause a fire.

Keep away from fire, when working with flammable substances such as grease.

* They may cause a fire.

* When handling grease, obey the manufacturer's SDS.

! If the engine is stored for 3 month or longer (up to 1 year), apply rust-preventive measure properly.

* Otherwise, the internal engine parts and/or sliding parts may be rusted, which could cause damage to the devices.

* Follow the storage procedure described in this Operation & Maintenance Manual.

Use volatile corrosion inhibitor and rust preventive oil recommended by us.

* If a product other than the recommendation is used, the internal engine parts may be rusted due to insufficient anti-rust effect.

Use new (immediately after opened) desiccant.

* If you use a product which has been unused for a long time since its package was opened, moisture absorbency may be weakened, and may cause the internal engine parts and/or sliding parts to rust.

After stopping the engine, spray volatile corrosion inhibitor while cranking the engine for at least 2 times.

* Otherwise, anti-corrosive agent may accumulate and harden on the piston, which could block turning.

⚠ CAUTION

! When handling volatile corrosion inhibitor or rust preventive oil, wear personal protective equipment such as protective mask or protective glasses, and obey the manufacturer's SDS.

* If such products are breathed in or comes in contact with the skin, serious personal injury may occur.

When working with grease, wear suitable personal protective equipment such as protective eyeglasses, rubber gloves, working clothes with long sleeves and long trousers.

* If grease comes into contact with your eyes, it will cause irritations.

* When handling grease, obey the manufacturer's SDS.

<Maintenance during Storage>

⚠ WARNING

⊘ Do not short the battery terminals.

* Otherwise, sparks could occur and cause a fire or an explosion.

! When checking and servicing the battery, wear suitable personal protective equipment such as protective eyeglasses, rubber gloves, working clothes with long sleeves and long trousers.

* If battery fluid comes into contact with your eyes or skin, it may result in sight loss or burns.

TRANSPORTATION

■ Precautions on Transportation

WARNING



When transporting the engine on a truck, consider the engine weight, width and height to ensure safety. Abide by road traffic law, road vehicles act, vehicle restriction ordinance and other pertinent laws.

* Operation of the truck disregarding the laws and regulations may cause traffic accident or damage to the devices.

Be extremely careful when transporting the engine on rough roads.

* Otherwise, a traffic accident such as rollover or damage to the devices may occur.

■ Engine - Lift

WARNING



When lifting up the engine, do not allow the operators to stay under the engine.

* Otherwise, if the wire breaks, the engine may fall down, which could cause serious personal injury.



The engine must be lifted only by an operator who is qualified for a crane and slinging works and also well skilled.

* Otherwise, the engine may fall by an operation error, which could cause serious personal injury or damage to the devices.

To lift the engine, take the mass of the engine and that of water remained in the engine into account, and use wire ropes, shackles, and slings which are strong enough to support the weight.

* Otherwise, the engine may slip down, which could cause serious personnel injury or damage to the devices.

* Check the contract specifications for engine dry mass.

Use sling/hoisting tools in accordance with their instruction manual.

* Otherwise, the engine may slip down, which could cause serious personnel injury or damage to the devices.

Use the hangers of the engine only for lifting the engine unit.

* If you use them when the engine is assembled with the generator and additional devices, the hanger may not be able to endure the mass and may break. If the engine falls, serious personnel injury or damage to the devices will occur.

Before lifting the engine, drain fuel, engine oil and coolant.

* Otherwise, the hanger may not be able to endure the mass and break. If the engine falls, serious personnel injury or damage to the devices may occur.

Lift the slings while keeping the angle formed by the slings attached to the hangers within 60°.

* If the angle is too large, excessive weight will be imposed on the hanger, which could cause damage to the hanger.

TROUBLESHOOTING

■ Precautions on Troubleshooting

⚠ DANGER



Before inspecting and maintaining the engine, read this Operation & Maintenance Manual thoroughly to understand the construction and the required work to service the corresponding part. In addition, conduct the work after fully studying the procedure.

- * In case of conducting the work without studying enough, an accident or damage due to wrong installation, or deterioration in the exhaust gas properties may occur.

⚠ WARNING



Do not take actions for items indicated as "Contact your MHIET dealer" in the measure column in the Scheduled Maintenance.

- * Otherwise, serious accident, environmental pollution or damage to the devices may occur. Be sure to contact your MHIET dealer.

Do not disconnect the pipes immediately after the engine is stopped.

- * Otherwise, you could get burned by hot engine oil or coolant splashing out.



When lifting a part or tool, check its weight and lift it slowly.

- * If you lift it carelessly, you may hurt your back or get injured by dropping the part.

Make sure that dripped oil, parts, tools or other things are not left on the floor around the engine. Always maintain cleanliness and tidiness.

- * Otherwise, a tumbling accident may occur.
- * Wear proper personal protective equipment for the work.

Make sure that the tools to be used are not damaged.

- * Using a damaged tool or a wrong-size tool may cause personal injury or damage to the devices.

Check and calibrate measurement equipment periodically.

- * Using uncalibrated measurement equipment may cause damage to the devices or performance degradation of them.

⚠ WARNING



Watch your step during inspection and maintenance work.

- * Otherwise, a tumbling accident or a falling accident may occur while working on the floor panel or other high positions.
- * The floor could be extremely slippery due to spilt oil. Thoroughly wipe off oil on the floor and the sole of your shoes.
- * Install a stable scaffold as required.

Before maintaining electrical components, place the battery switch to the OFF position or disconnect the battery negative (-) terminal.

- * Electric shock could result when electricity flows through the circuit.

Cover the disconnected pipes or joints and their openings properly so that dusts or other foreign objects will not enter into them.

- * Otherwise, the devices could be damaged.

DISPOSAL

■ Disposal Precautions

<Fuel - Drain>

WARNING

 **Do not discard waste oil into sewerage, river, lake or other similar places.**

* Be sure to discard waste oil in accordance with the applicable laws and regulations.

Keep away from fire, when working with flammable substances such as fuel.

* They may cause a fire.

 **When working with fuel, wear suitable personal protective equipment such as protective mask, protective eyeglasses, rubber gloves, working clothes with long sleeves and long trousers.**

* If fuel comes into contact with your eyes, mouth or skin, it will cause irritation or disorders.

Wipe off spilled flammable substances such as fuel thoroughly with a waste cloth.

* They may cause a fire.

When discarding a waste cloth used to wipe off combustible material, put it into a lidded can and obey the Waste Management and Public Cleansing Act to handle it as a special industrial waste.

* It may cause a fire.

* It could lead to environmental pollution.

* If you violate rules, you may be subject to penalties.

<Engine Oil - Drain>

WARNING

 **Do not discard waste oil into sewerage, river, lake or other similar places.**

* Be sure to discard waste oil in accordance with the applicable laws and regulations.

Keep away from fire, when working with flammable substances such as engine oil.

* They may cause a fire.

 **When handling engine oil, obey the manufacturer's SDS.**

* If engine oil gets in your eyes, it will cause pain and lead to sight loss at the worst.

Wipe off spilled flammable substances such as engine oil thoroughly with a waste cloth.

* They may cause a fire.

When discarding a waste cloth used to wipe off combustible material, put it into a lidded can and obey the Waste Management and Public Cleansing Act to handle it as a special industrial waste.

* It may cause a fire.

* It could lead to environmental pollution.

* If you violate rules, you may be subject to penalties.

<Coolant (LLC) - Drain>

⚠ WARNING

 **Do not discard coolant (LLC) into sewerage, river, lake or other similar places.**

* Be sure to discard coolant (LLC) in accordance with the applicable laws and regulations.

Keep away from fire, when working with flammable substances such as coolant (LLC).

* They may cause a fire.

 **When handling coolant (LLC), always wear suitable personal protective equipment such as rubber gloves and protective eyeglasses.**

* If LLC comes into contact with your eyes, it will result in sight loss at the worst.

* If LLC comes into contact with your skin while the engine is hot, you could get burned by heat.

Wipe off spilled flammable substances such as coolant (LLC) thoroughly with a waste cloth.

* They may cause a fire.

When discarding a waste cloth used to wipe off combustible material, put it into a lidded can and obey the Waste Management and Public Cleansing Act to handle it as a special industrial waste.

* It may cause a fire.

* It could lead to environmental pollution.

* If you violate rules, you may be subject to penalties.

<Anti-corrosive Agent, Rust Preventive Oil, Rust-preventive Fuel - Drain>

⚠ WARNING

 **Do not discard waste oil into sewerage, river, lake or other similar places.**

* Be sure to discard waste oil in accordance with the applicable laws and regulations.

Keep away from fire, when working with flammable substances such as volatile corrosion inhibitor or rust preventive oil.

* They may cause a fire.

⚠ CAUTION

 **When handling volatile corrosion inhibitor or rust preventive oil, wear suitable personal protective equipment such as protective mask or protective glasses, and obey the manufacturer's SDS.**

* If such products are breathed in or comes in contact with the skin, serious personal injury may occur.

<Battery Fluid (Dilute Sulfuric Acid) - Drain>

⚠ WARNING

 **Do not discard battery fluid (dilute sulfuric acid) into sewerage, river, lake, or other similar places.**

* Be sure to discard battery fluid (dilute sulfuric acid) in accordance with the applicable laws and regulations.

Never use flames or allow sparks near the battery.

* An explosion due to catching flame or a fire may occur.

 **When checking and servicing the battery, wear suitable personal protective equipment such as protective eyeglasses, rubber gloves, working clothes with long sleeves and long trousers.**

* If battery fluid comes into contact with your eyes or skin, it may result in sight loss or burns.

<Engine Body - Disposal>

⚠ WARNING

In case that you have to discard the engine body, contact your MHIET dealer.

* You must deal with it as a special industrial waste in accordance with the laws and regulations of the national government and other local municipalities.

Asbestos, mercury, and heavy metal (lead) were used in the parts of the engines that were manufactured in 2005 or earlier. Therefore, when discarding them, obey the "Waste Management and Public Cleansing Act".

* If you violate rules, you may be subject to penalties.

⚠ CAUTION

While discarding the engine body, be sure to wear the appropriate personal protective equipment.

* Without wearing or not properly wearing personal protective equipment, serious personal injury may occur.

<Other Disposal>

⚠ WARNING

When discarding a waste cloth used to wipe off combustible materials such as fuel, the engine oil, and coolant (LLC), put it into a lidded can and obey the Waste Management and Public Cleansing Act to handle it as a special industrial waste.

* It may cause a fire.
* It could lead to environmental pollution.
* If you violate rules, you may be subject to penalties.

⚠ CAUTION

Lift and transport an engine or a heavy object such as tank filled with waste oil or fluid with a forklift only by the qualified operator.

* Otherwise, the heavy object may fall due to improper transportation, and the operator may get injured.
* And the waste oil or fluid leak may occur, which could cause environmental pollution.

Protection Devices**Protection Devices on the Engine**

On this engine, protection devices are incorporated in order to ensure the operators' safety and prevent personal injury and damage to the engine.

The protection devices incorporated in the engine will not function by themselves. Affix the information (types, location, functions, etc.) of the protection devices added at the time of the generator's production onto "[Protection Devices Added during Manufacturing the Generator](#)" (→ [Page 15](#)) as "Usage Information" for the operator. It is very important for ensuring safety to maintain these functions in order. Therefore, conduct the scheduled maintenance.

Note

- **The functional check of the protection devices must be conducted properly in conformity to the operation status of this engine. Schedule functional checks of the protection devices.**
- **Follow the working methods and procedures while taking advantage of the permanently-installed protection devices. Never deactivate the protection devices.**
- **The location of the protection devices varies depending on the specification of the engine. Refer to "[Protection System - Location](#)" (→ [Page 83](#)).**
- **Equipped or not equipped, type, setting value and figure of each protection device vary depending on the equipment and specifications. Check the protection devices of your engine at first.**

■ Oil Pressure Switch

The oil pressure switch will send a signal when the engine oil pressure has dropped and reached the specified pressure.

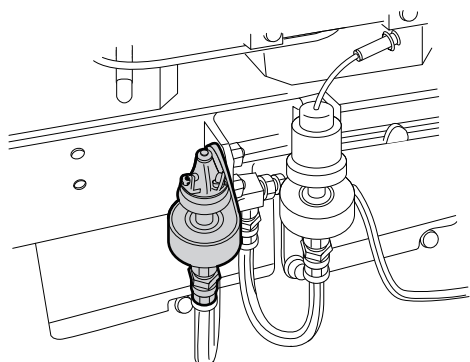

Fig. 1-2 Oil Pressure Switch

■ Thermo Switch

The thermo switch will send a signal when the engine coolant temperature becomes high and reaches the specified temperature.

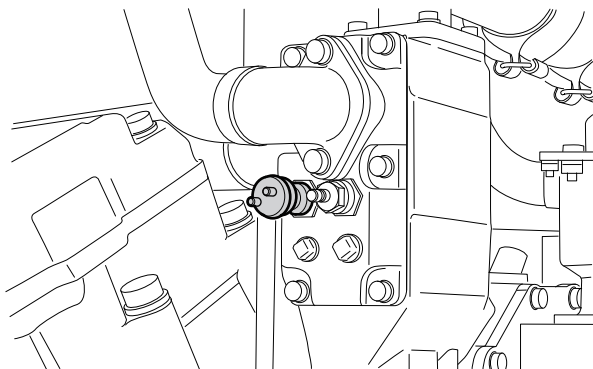

Fig. 1-3 Thermo Switch

■ Oil Filter Alarm Switch

The oil filter alarm switch will send a signal when the difference in pressure across the filter reaches the specified value due to clogged oil filter.

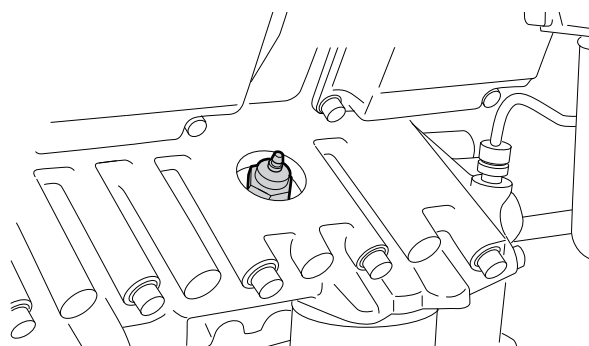

Fig. 1-4 Oil Filter Alarm Switch

■ Rotation Detection Pickup

The pickup will send a signal when the engine speed becomes high and reaches the specified engine speed.

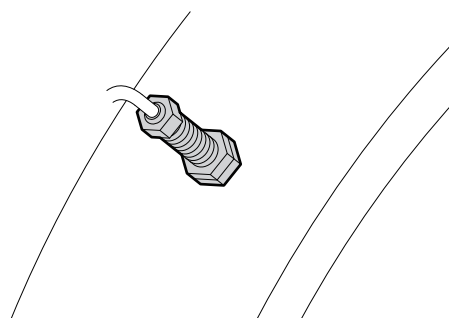

Fig. 1-5 Rotation Detection Pickup

Lockout/Tagout

Lockout/tagout is a measure to avoid other personnel to get injured by mistakenly switching ON the power source during the work conducted by multiple operators, and it is very effective for ensuring safety.

In Japan, the Ordinance on Industrial Safety and Health, Article 107 "Stoppage of Operation etc., in the Case of Cleaning, etc." requires to lockout/tagout.

Details of implementation and management of lockout/tagout are described in OSHA§1910.147 issued by the Occupational Safety and Health Administration. OSHA§1910.147 can be browsed at the Internet website of OSHA.

Note

- **The customer is required to prepare the tags.**
- **Prepare tags of the expected numbers of operators if multiple operators are to work in a dangerous area.**

Lockout

Lockout is intended for ensuring safety when the operators enter the dangerous area for maintenance work such as replacing parts.

- Shut off all the power source and set to Zero Energy State "[Zero Energy State](#)" (→ [Page 63](#)).
- Lock up the power source so that the other operators will not be able to switch on the power source.
- The operator in charge must hold the key so that other operators will not be able to open the lock.

Tagout

Tag-out is to attach a tag indicating a warning so that no one will not activate the control panel that was put in a stopped state.

Tags must include the name of the responsible person who supervise the work or the operator who attached the tag.

After completing the work, the operator shall fill in the work completion date and time and signature in the work management table and report it to the user company or supervisor.

The user company or supervisor must prepare a work management table in advance. If a work that requires tagouts arises, the user company or supervisor must record the working classification, person in charge, and tag number in a table, and keep the record.

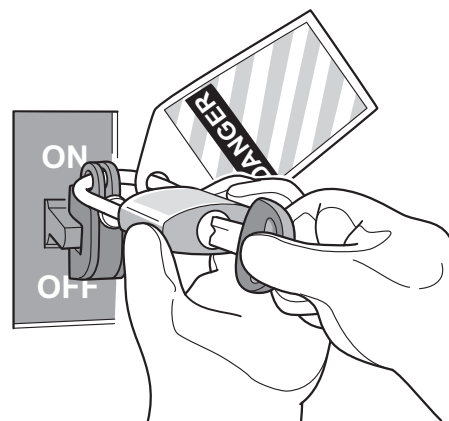

Fig. 1-6 Lockout/Tagout (Example)

Zero Energy State

"Zero Energy State" is to maintain the condition to inhibit unexpected energy releases or inputs during maintenance work. In other words, Zero Energy State is to prevent unexpected output or input of energy when the engine is not used, even if the potential energy is not zero.

Note

- **You must know how to set the engine to Zero Energy State.**
- **When setting the generator to Zero Energy State, refer to the corresponding manual of the generator.**

How to Set the Engine to Zero Energy State

- 1 **Operate the stop switch of the generator ["Starting and Stopping Devices Installed during Manufacturing the Generator"](#) (→ [Page 87](#)) to turn off the engine.**
- 2 **Make sure the engine has stopped.**
- 3 **Set the battery switch to "OFF", or disconnect the battery negative (-) terminal to isolate from main power source.**
- 4 **Disconnect the external equipment (set the relay of the generator "OFF", etc.).**

For engines with the air direct admission starting or air motor starting system, conduct the following operation in addition.

- 5 **Bleed air trapped in the air starter system (starting air tank, starting air compressor) to release the residual pressure.**

Working Procedure in Dangerous Areas

Works in Dangerous Areas

When you need to enter a dangerous area, for example, to fix a problem that has occurred during operation, follow the procedure below.

■ Works that Require Lockout/Tagout

Note

- **When you conduct a work which can not be done for a short time, for example, when replacing a part, conduct lockout/tagout for ensuring safety.**

- 1 **Operate the stop switch of the generator ["Starting and Stopping Devices Installed during Manufacturing the Generator"](#) (→ [Page 87](#)) to turn off the engine.**
- 2 **Lock the starting switch of the generator ["Starting and Stopping Devices Installed during Manufacturing the Generator"](#) (→ [Page 87](#)) with a key and hang a tag, as necessary.**

Note

- **Tags must be hanged, as necessary, by considering the number of the operators, difficulties to check the presence of each other, or the working times.**

- 3 **Conduct the works.**

After completing the works, restore the condition as follows.

- 1 **Inform the other operators that the works have been completed.**
- 2 **Remove the key and tag from the starting switch of the generator.**
- 3 **Check for any operators remaining in the dangerous area.**
- 4 **Inform the user company or supervisor that the works have been completed.**
- 5 **Start up the engine by the normal operation procedure.**

Body Protection

When working on this engine, obey the requirements below in order to protect the operator.

Clothing

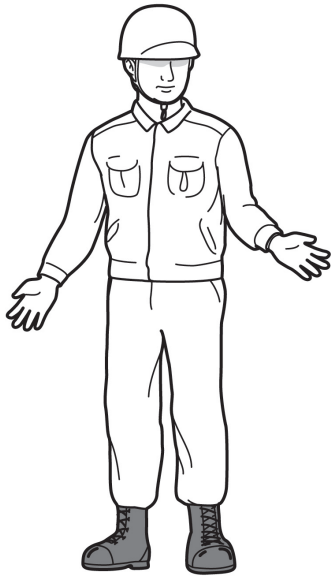

Fig. 1-7 Clothing

Be sure to wear the appropriate protective clothing to work.

- Wear tight clothing and fasten cuffs firmly.
- Proper work clothing is valuable protection against electrical shock.
- If you work while wearing a short sleeved shirt or short-pants, you may get injured when you come into contact with something.

Note

- **For handling fuel, the engine oil, coolant, and anti-corrosive agent, refer to SDS "[Dangerous and Hazardous Chemicals](#)" (→ [Page 72](#)).**

Personal Protective Equipment

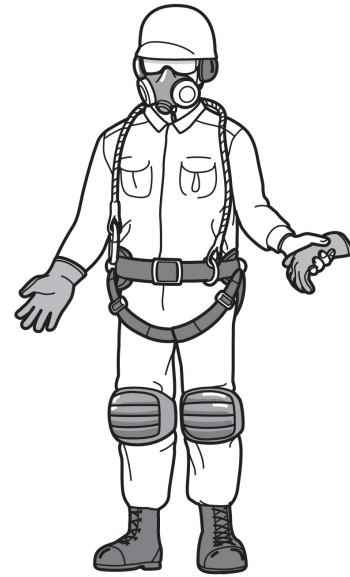

Fig. 1-8 Personal Protective Equipment

Note

- **Personal protective equipment vary depending on the working environment and works (operation, diagnosis, inspection and maintenance, and so on). Specify the rules, and wear the required personal protective equipment.**

<Personal protective equipment to be worn, in general>

- Working clothes
- Safety shoes
- Hard hat
- Protective glasses
- Protective mask (gas mask)

<Personal protective equipment to be added according to the working environment and works>

- Earplugs (hearing personal protective equipment)
- Plastic gloves (when handling the dangerous and toxic chemicals)
- Safety belt (when working at the high position)

Product-specific Precautions

Use of Chemicals

This engine uses fuel (diesel fuel), engine oil, coolant (LLC), grease, and anti-corrosive agent. If these come into contact with your eyes or skin, they may cause skin burns or abnormal sight (sight loss at the worst).

To prevent an accident, take measures given below.

- When handling, wear proper personal protective equipment.
(protective glasses, protective mask (gas mask), plastic gloves)
- Wear working clothes with long sleeves and trousers to protect the skin.

Surface Temperature

A surface of this engine during operation or immediately after operation is raised to high temperature (approx. 180°C [356°F]) by location, and therefore if you touch it, you could get burns. After making sure with the thermometer (thermo gun, etc.) that a surface of the engine is cooled down so that you can touch (approx. 40°C [104°F]), conduct the inspection and maintenance work.

Precautions on Additional Equipment

Water Heater

⚠ WARNING



Do not touch the water heater even after stopping of the engine.

- * Even after stopping, water heater is at high temperature and touching it may cause burns.



For the generator with a water heater, connect the wiring of the water heater correctly.

- * Otherwise, flue explosion may occur, which could cause serious personal injury or damage to the devices.

For the generator with a water heater, always set the water heater switch to "ON".

- * If you start up the engine when the water heater switch is "OFF", incomplete combustion may occur, which could result in flue explosion or deterioration in the exhaust gas properties.

For generators for emergency use with a water heater, be sure to follow the instructions below:

Note

- **The water heater is outside the scope of our supply. For the details, refer to the corresponding manual of the generator.**

- Always place the water heater switch in the ON position to maintain the cooling water temperature to the proper value (35°C [95°F] or more).
- If you had to set the water heater switch to "OFF" for inspection and maintenance, be sure to set the switch back to "ON" after completing the work.
Start up the engine only after the coolant temperature reaches the proper temperature (35°C [95°F] or more).

Develop the Action Procedure to Obey in the Event of Emergency

It is important to create the action procedure for emergency situations to rescue and assist the operators involved in an accident.

Examples of the items that should be included in the action procedure of emergency are shown below as a reference.

- (a) Appointment of a contact person as an assistant person for rescue work.
- (b) Include at least one rescue trained person in each work party.
- (c) Preparation of suitable tools and equipment required for rescue work

⚠ WARNING



Prepare first-aid kits and first aid tools.

* Otherwise, in case of personal injury, first aid treatment can be delayed, which may cause death in the worst case.

Prepare an emergency action plan in the event of emergency (fire, accidents, etc.) including emergency contact points and means of communication.

* Delay in action will result in expansion of damage.

Keep Everyone Informed about the Emergency Stop Procedure

Compile the information about the protection devices, fuel, engine oil, pipings of the cooling and inlet/exhaust system installed during manufacturing the generator and attach it on the next page.

Also ensure that their locations and function are instructed to, and understand by the operators in addition to the details of the "Safety Manual".

Measures in the Event of Emergency

Emergency Stop Procedure

Thoroughly understand the stopping procedure to be followed in the event of emergency.

- 1 **Use the emergency stopping devices of the generator "[Emergency Stopping Devices Installed during Manufacturing the Generator](#)" ([→ Page 67](#)).**
- 2 **If the engine does not stop, pull the manual stop lever of the engine in the stop direction, and hold the lever in this position.**

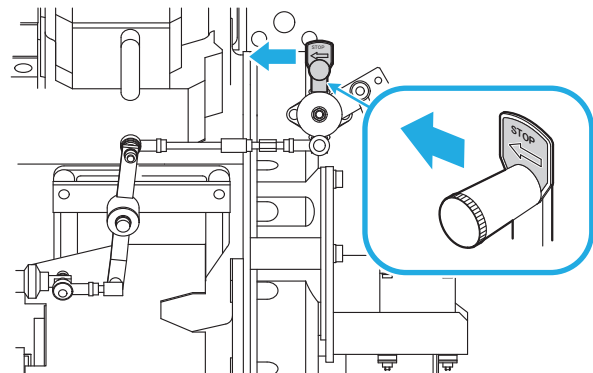

Fig. 1-9 Emergency Stop Procedure

Note

- **The location of the manual stop lever varies depending on the specification of the engine. Refer to "[Protection System - Location](#)" ([→ Page 83](#)).**

- 3 **After the engine has stopped completely, release the manual stop lever.**

⚠ WARNING



When stopping the engine by pulling the manual stop lever, keep pulling the lever until the engine stops completely.

* Otherwise, the engine may start again.

If the stop switch of the generator will not function and the engine will not stop by using the manual stop lever, shut off fuel supply.

* Otherwise, the extent of damage may increase.

Emergency Stopping Devices Installed during Manufacturing the Generator

Please read first

The user company must compile the information about the emergency stopping devices installed during manufacturing the generator and attach it here.

Measures in the Event of Personal Injuries Resulting from This Engine

In case a personal injury occurs unfortunately, act in accordance with the following.



Fig. 1-10 Measures in the Event of Personal Injury

- 1 **Check your surroundings and save human lives.**
- 2 **Call for emergency services of the following organizations.**
 - (a) Fire department
 - (b) Supervisory authorities
- 3 **After conducting the emergency measures, contact your MHIET dealer "CONTACT LIST" (→ Page 10) as soon as possible.**

Measures in the Event of Property Damaging Disasters

If the engine has been damaged due to a wrong handling during operation, act in accordance with the procedure shown below.



Fig. 1-11 Measures in the Event of Property Damaging Disasters

- 1 **Contact your MHIET dealer "CONTACT LIST" (→ Page 10) immediately.**

Note

- **If the engine has been damaged, exact damage situation cannot be judged only by visual check. Be sure to contact your MHIET dealer "CONTACT LIST" (→ Page 10), since their cooperation is essential for checking the damage situation.**
- 2 **In order to prevent the damage from spreading, stop the engine operation after the disaster occurred and follow the instruction by your MHIET dealer "CONTACT LIST" (→ Page 10).**

Measures in the Event of Environmental Disaster

If waste oil have been mistakenly discharged through drain ditches, act in accordance with the procedure shown below.

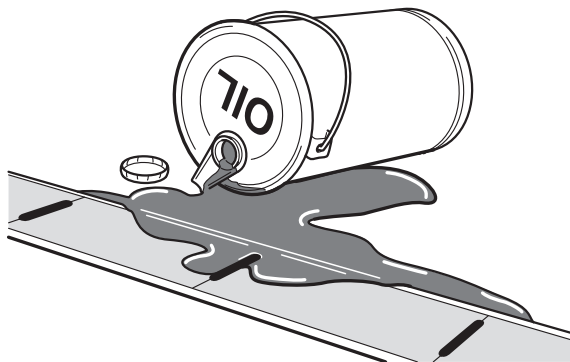

Fig. 1-12 Measures in the Event of Environmental Disaster

1 Call for emergency services of the following organizations.

- (a) Public agency, which performs local environment management
- (b) Fire department
- (c) Police department
- (d) Fishermen's union

2 Act as instructed by the public agency.

Measures in the Event of a Fire Disaster Resulting from This Engine

If a fire has occurred during operation, act in accordance with the following procedure.



Fig. 1-13 Measures in the Event of a Fire Disaster

- 1 **The operator who has found a fire must shout "fire!" to the other people around him immediately.**
- 2 **If there is any injured persons, take them to a safety place and perform proper emergency medical procedures.**
- 3 **Call the fire department.**
- 4 **Use a fire extinguisher which is suitable for the type of fire to extinguish the fire.**

⚠ WARNING



Prepare fire-fighting equipments and fire extinguishers. If you are obliged to prepare fire extinguishers by various laws and regulations, be sure to place them.

- * In case of a fire, delay in fire suppression will result in expansion of damage.
- * To extinguish engine fire, it is recommended to use an ABC dry-powder fire extinguisher which has the effect of suppressing of both of oil and electrical fires.

⚠ WARNING

! To extinguish the oil fire or an electrical fire, use an extinguisher suitable for the type of fire.

- * If you try to use water to extinguish the oil fire, the fire will get worse.
- * To extinguish engine fire, it is recommended to use an ABC dry-powder fire extinguisher which has the effect of suppressing of both of oil and electrical fires.

5 The user company or supervisor must contact the MHIET dealer "[CONTACT LIST](#)" (→ [Page 10](#)).

Note

- **Regardless of the size or cause of the accident, report the details to your MHIET dealer "[CONTACT LIST](#)" (→ [Page 10](#)).**
- **Place fire extinguishers at locations out of direct sunlight, with low humidity, kept out of rain, and conspicuous.**
- **Check the fire extinguishers for rust and deformation of the body once a year or more, and change the extinguishing agent approx. every 5 years.**
- **Escape from the scene immediately after extinguishing a fire with fire extinguishers including CO₂-agent.**

Measures in the Event of an Earthquake Disaster

If an earthquake has occurred during operation, act in accordance with the following procedure.

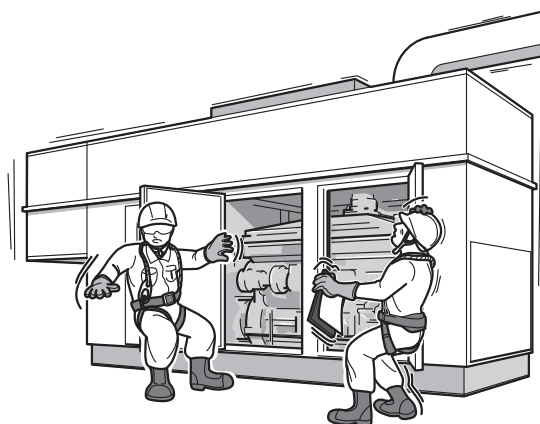

Fig. 1-14 Measures in the Event of an Earthquake Disaster

- 1 If there is any injured persons, take them to a safety place and perform proper emergency medical procedures.**
- 2 The user company or supervisor must lead all the operators to a safe place in accordance with the company rules.**
- 3 After confirming that there is not a possibility of earthquake recurrence, check the following points.**
 - (a) Damage to the engine
 - (b) Falling objects near and inside of the engine
 - (c) Condition of pipings and wirings
 - (d) Abnormality of electric power

Note

- **If any abnormalities are found, contact your MHIET dealer "[CONTACT LIST](#)" (→ [Page 10](#)).**

Occupational Health and Safety Management

The following is a summary of the Occupational Health and Safety Management that you have to conduct.

For the operations concerning this engine, develop the "Safety and Health Planning" on the basis of the "Guidelines for Occupational Safety and Health Management System" (ILO-OSH2001), and observe it to conduct them.

In addition to the requirements of the national government and other local municipalities as well as your original safety management rules, use this to prevent accident to a human casualties, property damage and environmental accident.

Operation & Maintenance Manual - Understand and Obey

Let the operators thoroughly understand the details described in this Operation & Maintenance Manual, and conduct the training to prevent risks at the actual engine.



Fig. 1-15 Operation & Maintenance Manual - Understand and Obey

Education and Training for Safety

Safety skills of the personnel can be improved by teaching as with skills of the other works. Be sure to include the points concerning safety in your education and training.

The safety measures for specific works can be instructed in our operation training of the engine, however these are not enough.

It is necessary for the customer to recognize potential risks and have a sense of alertness. In addition, you must improve your awareness of safety so as to respond sensitively to danger and conform the established procedure.

If awareness of safety is boosted, you can judge situations, and avoid dangerous actions and dangerous places by yourself, or exclude potential dangers so as to act behaviors to safeguard yourself.



Fig. 1-16 Education and Training for Safety

Dangerous and Hazardous Chemicals

Exposure to chemical substances causes or contributes to significant health problems such as heart disease, kidney and lung damage, infertility, cancer, burns and rashes.

Also, some chemical substances have a risk of causing fire, explosion, and other serious disasters if you make a mistake in handling.

When purchasing hazardous chemical substances, obtain SDS from the manufacturer and store them in the place where you can access as soon as they needed.



Fig. 1-17 Hazardous Chemical Substances

If you are in poor physical condition due to the use of hazardous chemical substances and you are going to see the doctor, give SDS to your doctor. In order to handle these hazardous chemical substances, information supply, education, and training to operators are required according to JIS Z 7253, ISO 11014.

Information supply, education and training to operators who handle chemical substances shall include the following:

- (a) Appropriate ventilation shall be provided in areas where hazardous materials are used.
- (b) Handling and storage of hazardous materials shall be in accordance with the manufacturer's recommended handling procedures.
- (c) Labels shall be affixed to the containers of hazardous materials and the handling shall be according to the manufacturer's instruction. Keep the chemicals away from hot places, sparks and flame. Store in a cool and dry condition.
- (d) Before handling hazardous materials, check the manufacturer's SDS, and follow the handling procedures.
- (e) When handling hazardous materials, get the operators to wear personal protective equipment in accordance with handling procedures of SDS prepared by the manufacturers.
- (f) If there is possibility of eye injuries due to hazardous material, the location of eye washer and how to use it shall be informed in advance.
- (g) Operators who handle hazardous materials should wash their hands before eating or drinking.

■ Disposal of Waste Oil, Waste Fluid, and Waste Materials

Chemical substances (such as solvents) used in machinery, and the cleaning cloths used to wipe off chemicals are subject to many restrictions at the time of their disposal in terms of environmental conservation.

Management is required according to national and local government and voluntary regulations by customers. ISO 14001 certified companies shall observe the procedure specified by the company.

■ Contents of SDS (Safety Data Sheet)

SDS contains detailed information on health and safety hazards, environmental impacts, safe handling methods, emergency response, etc.

Noise

In an environment at dangerous noise levels, the operators could suffer permanent auditory disorder. Therefore, noise is an important element for the health and safety management in the factory. Auditory disorder occurs by the following unsafe behaviors.

- Entering a dangerous area without wearing earplugs (hearing personal protective equipment).
- Staying in a dangerous area without earplugs (hearing personal protective equipment) or with improper personal protective equipment for a long time.

The noise level near the engine exceeds 85 dB during operation. Therefore, do not stay in a dangerous area without wearing earplugs (hearing personal protective equipment) for a long time. Preparation of facilities such as a cubicle (bonnet) is recommended.



Fig. 1-18 Noise

Note

- **For the noise level, refer to the factory test results statement held by the generator supplier.**

■ Noise Level during Operation

The actual measured value of the engine at maximum speed during operation is 115 dB.

Note

- **Measured at the point 1 m [39.37 in.] away from the engine.**
- **Wear earplugs (hearing personal protective equipment) during engine operation.**
- **This is a result which was measured in our factory. The actual noise level varies depending on the environment. (Ceiling height, size of the engine installation space, facilities of the generator)**

Vibration

- Some problematic vibrations may occur in association of business actions in the factory or workplace. In an engine, vibration occurs by the rotation.
- Vibration may shake buildings and cause damage to properties and personnel.

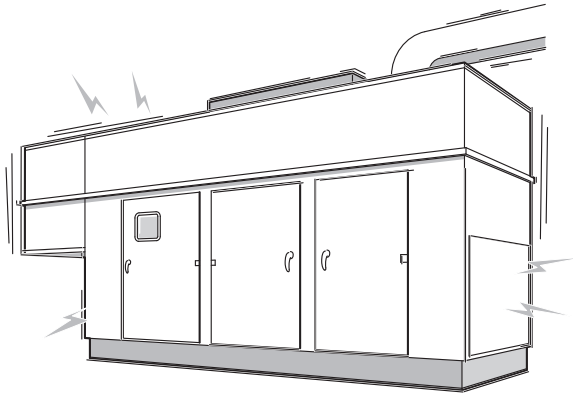

Fig. 1-19 Vibration

Note

- **For the vibration level, refer to the factory test results statement held by the generator supplier.**

To Maintain Cleanliness and Tidiness

If you do not keep the work place tidy and clean, you may stumble over an obstacle or fall over. Also, cleanliness and tidiness has a significant influence on the operations.

Sufficiently maintaining cleanliness and tidiness will increase the working efficiency and decrease the possibility of accidents.

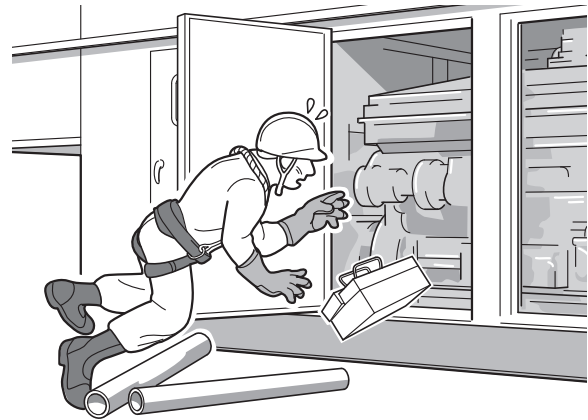

Fig. 1-20 To maintain cleanliness and tidiness

Risk of Fire

Although it is important to strive to prevent fire, training on a routine basis is necessary for fire prevention.

The following is general fire prevention measures.

- Do not leave combustible materials near the fire-using area.
- If you have to use fire, obtain permission from the user company or supervisor in advance.
- When conducting welding or gas cutting works, use an incombustible sheet, etc. to prevent a fire.
- When using fire, have a fire extinguisher handy.
- Cleanup after using fire.
- Install fire extinguishers and fire hydrants and perform periodic replacement.
- If the coating of electric wiring is damaged, repair or replace promptly.
- To prevent a fire due to deteriorated wiring, inspect the wiring for deterioration and replace as required.
- Take measures to prevent generation of static electricity.

In addition to above, always conduct the measures for fire prevention.



Fig. 1-21 Fire Hazard

Communication with MHIET

Please inform MHIET about the points you have noticed about safety when contracting and having the engine delivered, or while operating the engine. MHIET is willing to have sufficient communication with the customer.



Fig. 1-22 Communication with MHIET

Note

- **For the details described in this Operation & Maintenance Manual, if you want to have more detailed information or questions, contact your MHIET dealer "[CONTACT LIST](#)" ([→ Page 10](#))**
- **If you establish the protection measures, use this Operation & Maintenance Manual and warning labels on this engine and each device as "Usage Information".**

2 ENGINE - OUTLINE

This chapter describes the engine parts and the location of protection devices.

The descriptions are based on the standard data of an engine built as a unit, which may become altered depending on the specifications of your devices or the construction work made by the generator supplier.

Names of Parts

Refer to the pages corresponding your engine type.

- S16R-Y1PTA, S16R-Y1PTA-1, S16R-Y1PTA-2, S16R-Y1PTA-3, S16R-Y1PTA-4..... [77](#)
- S16R-Y1PTAA2, S16R-Y1PTAA2-1, S16R-Y1PTAA2-3..... [79](#)
- S16R-Y2PTAW, S16R-Y2PTAW-1, S16R-Y2PTAW2, S16R-Y2PTAW2-1..... [81](#)

S16R-Y1PTA, S16R-Y1PTA-1, S16R-Y1PTA-2, S16R-Y1PTA-3, S16R-Y1PTA-4

■ Engine Front View, Engine Rear View

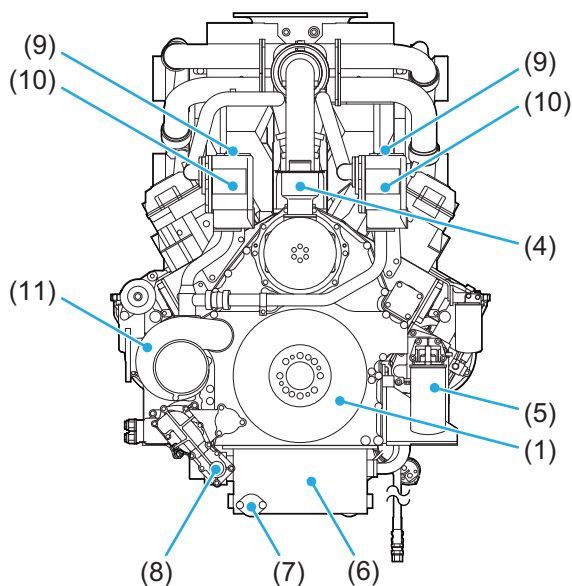

	No.	Name
Engine body	(1)	Damper
	(2)	Flywheel
Fuel system	(3)	Governor actuator
Lubrication system	(4)	Breather
	(5)	Bypass oil filter
	(6)	Oil pan
	(7)	Engine oil drain port
	(8)	Oil pump

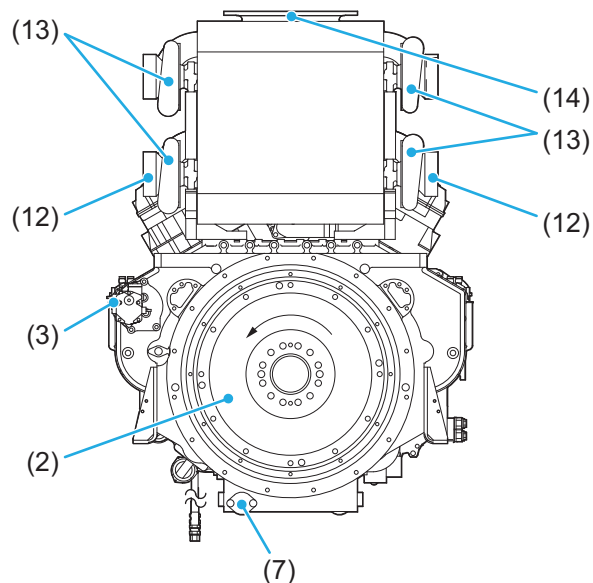

	No.	Name
Cooling system	(9)	Coolant outlet
	(10)	Thermostat case
	(11)	Water pump
Inlet and exhaust systems	(12)	Intake port
	(13)	Turbocharger
	(14)	Exhaust pipe Exhaust outlet

■ Right Side View

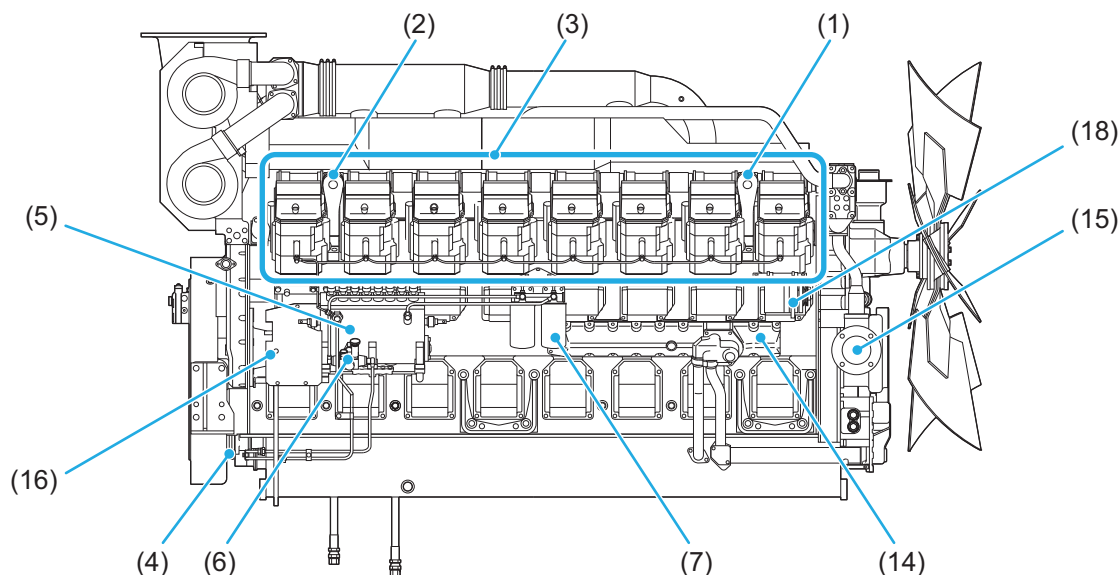

■ Left Side View

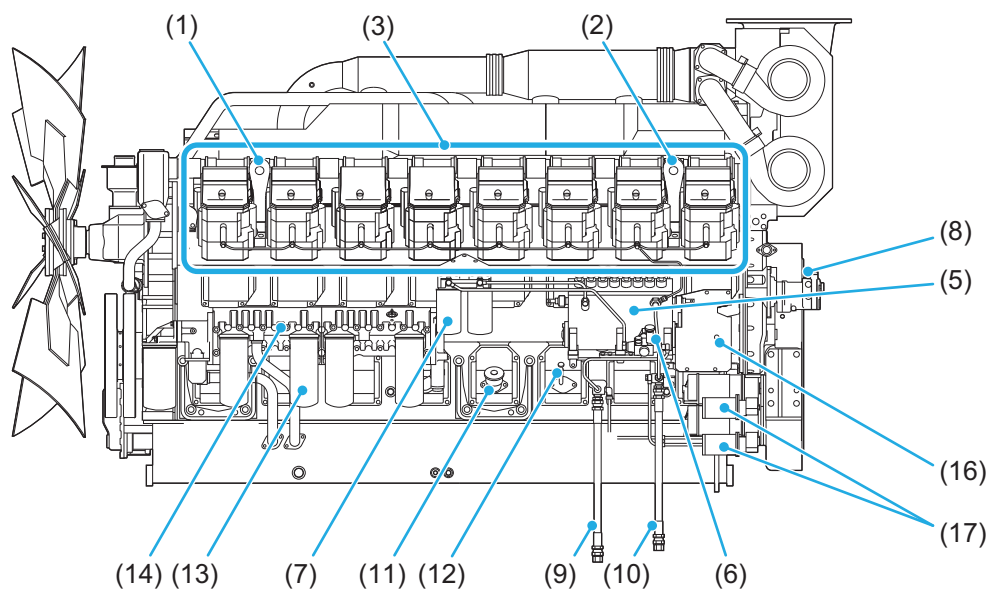

	No.	Name		No.	Name
Engine body	(1)	Front hanger	Lubrication system	(11)	Oil filler
	(2)	Rear hanger		(12)	Oil level gauge
	(3)	Cylinder head		(13)	Oil filter
	(4)	Manual turning gear		(14)	Oil cooler
Fuel system	(5)	Fuel injection pump	Cooling system	(15)	Coolant inlet
	(6)	Priming pump/ Fuel feed pump	Starting system	(16)	Coolant drain cock
	(7)	Fuel filter	Electrical system	(17)	Starter
	(8)	Fuel control link		(18)	Alternator
	(9)	Fuel inlet			
	(10)	Fuel return port			

S16R-Y1PTAA2, S16R-Y1PTAA2-1, S16R-Y1PTAA2-3

■ Engine Front View, Engine Rear View

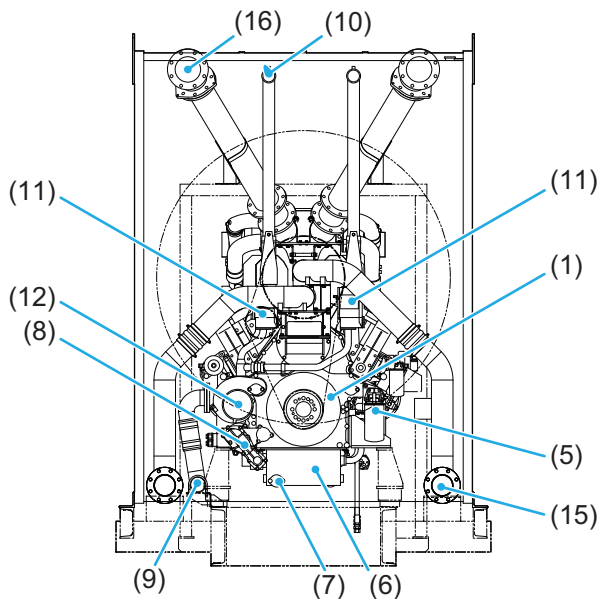

	No.	Name
Engine body	(1)	Damper
	(2)	Flywheel
Fuel system	(3)	Governor actuator
Lubrication system	(4)	Breather
	(5)	Bypass oil filter
	(6)	Oil pan
	(7)	Engine oil drain port
	(8)	Oil pump

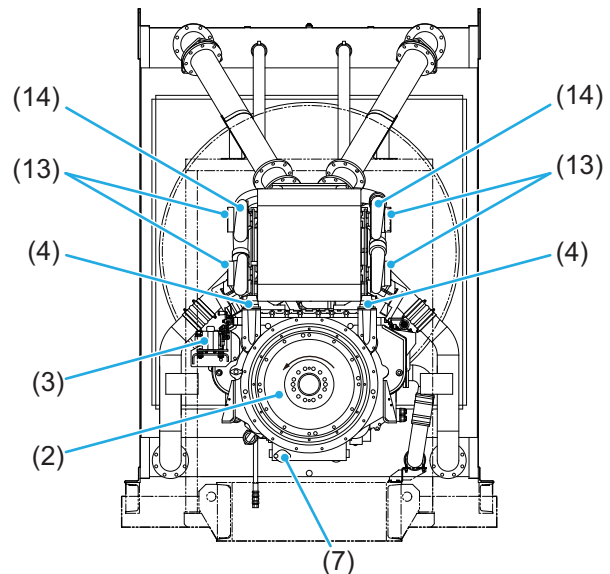

	No.	Name
Cooling system	(9)	Engine coolant inlet (from radiator)
	(10)	Engine coolant outlet (to radiator)
	(11)	Thermostat case
	(12)	Water pump
	(13)	Intake port
Inlet and exhaust systems	(14)	Turbocharger
	(15)	Intake port (from radiator)
	(16)	Air supply outlet (to radiator)

■ Right Side View

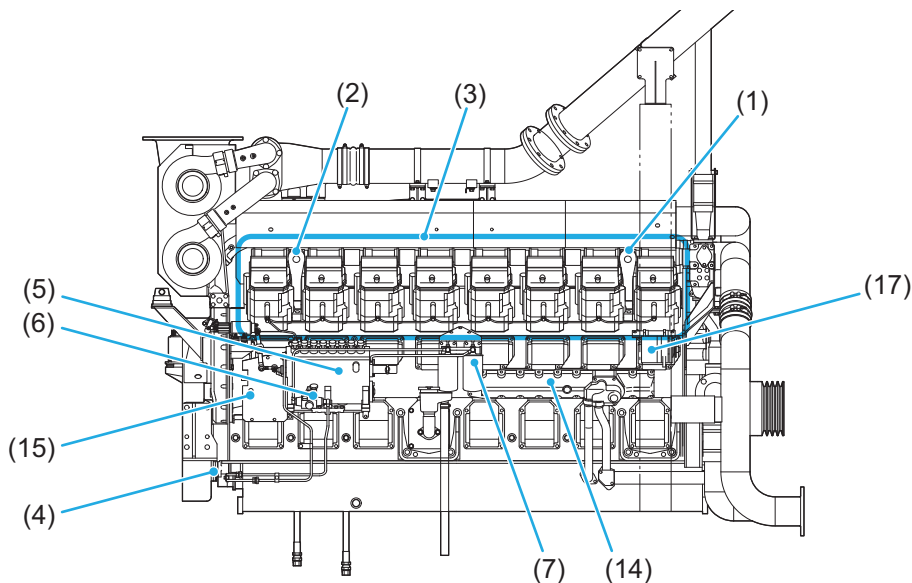

■ Left Side View

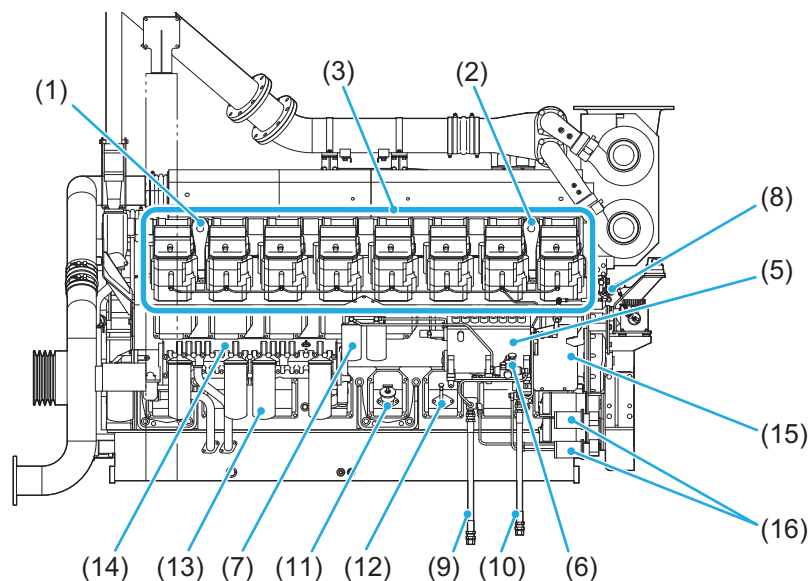

	No.	Name		No.	Name
Engine body	(1)	Front hanger	Lubrication system	(11)	Oil filler
	(2)	Rear hanger		(12)	Oil level gauge
	(3)	Cylinder head		(13)	Oil filter
	(4)	Manual turning gear		(14)	Oil cooler
Fuel system	(5)	Fuel injection pump	Cooling system	(15)	Coolant drain cock
	(6)	Priming pump/ Fuel feed pump	Starting system	(16)	Starter
	(7)	Fuel filter	Electrical system	(17)	Alternator
	(8)	Fuel control link			
	(9)	Fuel inlet			
	(10)	Fuel return port			

S16R-Y2PTAW, S16R-Y2PTAW-1, S16R-Y2PTAW2, S16R-Y2PTAW2-1

■ Engine Front View, Engine Rear View

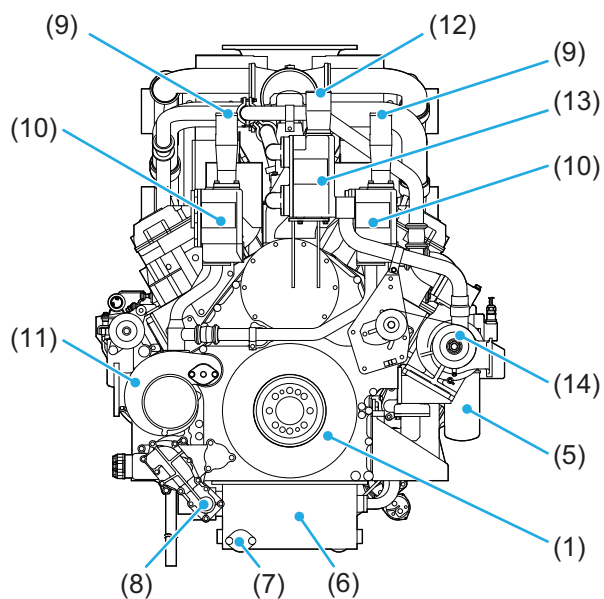

	No.	Name
Engine body	(1)	Damper
	(2)	Flywheel
Fuel system	(3)	Governor actuator
Lubrication system	(4)	Breather
	(5)	Bypass oil filter
	(6)	Oil pan
	(7)	Engine oil drain port
	(8)	Oil pump

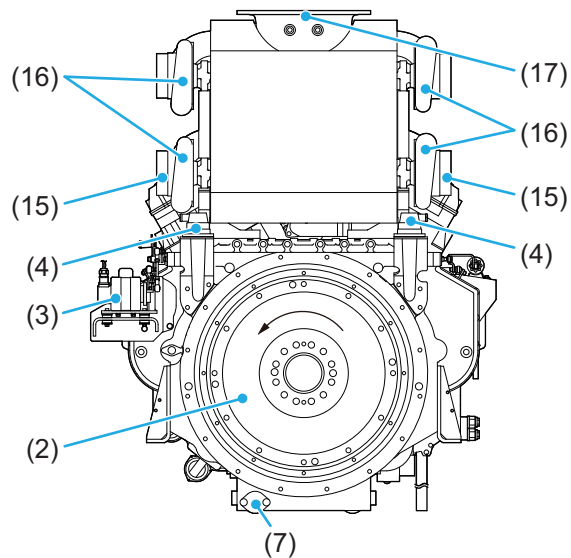

	No.	Name
Cooling system	(9)	Engine coolant outlet
	(10)	Thermostat case
	(11)	Water pump
	(12)	Air coolant outlet
	(13)	Thermostat case for air cooler
Inlet and exhaust system	(14)	Water pump for air cooler
	(15)	Intake port
Inlet and exhaust system	(16)	Turbocharger
	(17)	Exhaust outlet

■ Right Side View

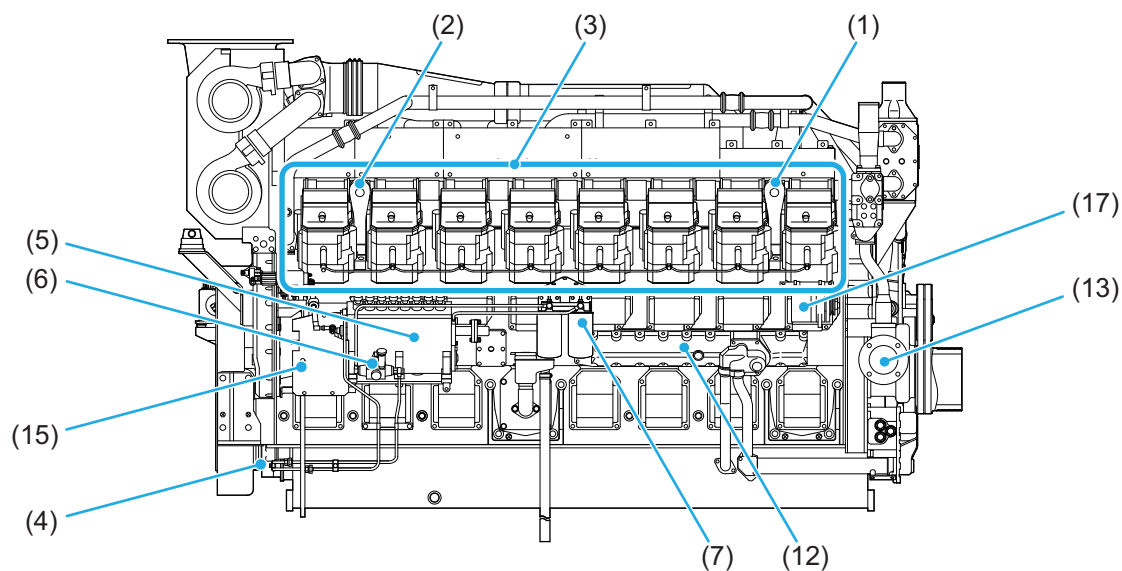

■ Left Side View

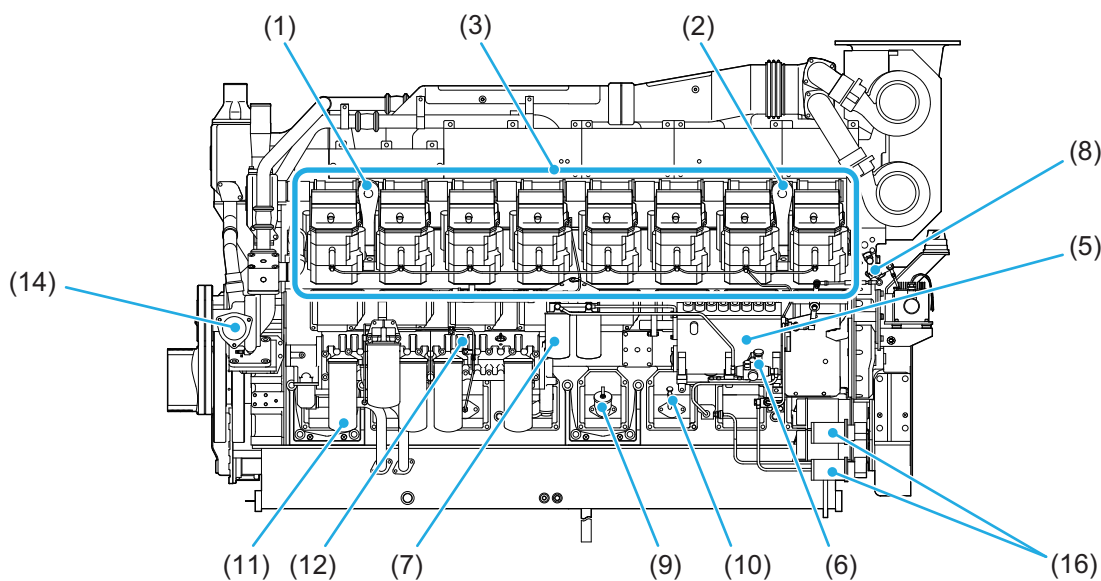

	No.	name
Engine body	(1)	Front hanger
	(2)	Rear hanger
	(3)	Cylinder head
	(4)	Manual turning gear
Fuel system	(5)	Fuel injection pump
	(6)	Priming pump/ Fuel feed pump
	(7)	Fuel filter
	(8)	Fuel control link

	No.	Name
Lubrication system	(9)	Oil filler
	(10)	Oil level gauge
	(11)	Oil filter
Cooling system	(12)	Oil cooler
	(13)	Engine coolant inlet
Starting system	(14)	Air cooler coolant inlet
	(15)	Coolant drain cock
Electric system	(16)	Starter
	(17)	Alternator

Protection System - Location

Refer to the pages corresponding your engine type.

- S16R-Y1PTA, S16R-Y1PTA-1, S16R-Y1PTA-2, S16R-Y1PTA-3, S16R-Y1PTA-4..... [84](#)
- S16R-Y1PTAA2, S16R-Y1PTAA2-1, S16R-Y1PTAA2-3..... [85](#)
- S16R-Y2PTAW, S16R-Y2PTAW-1, S16R-Y2PTAW2, S16R-Y2PTAW2-1..... [86](#)

S16R-Y1PTA, S16R-Y1PTA-1, S16R-Y1PTA-2, S16R-Y1PTA-3, S16R-Y1PTA-4

■ Right Side View

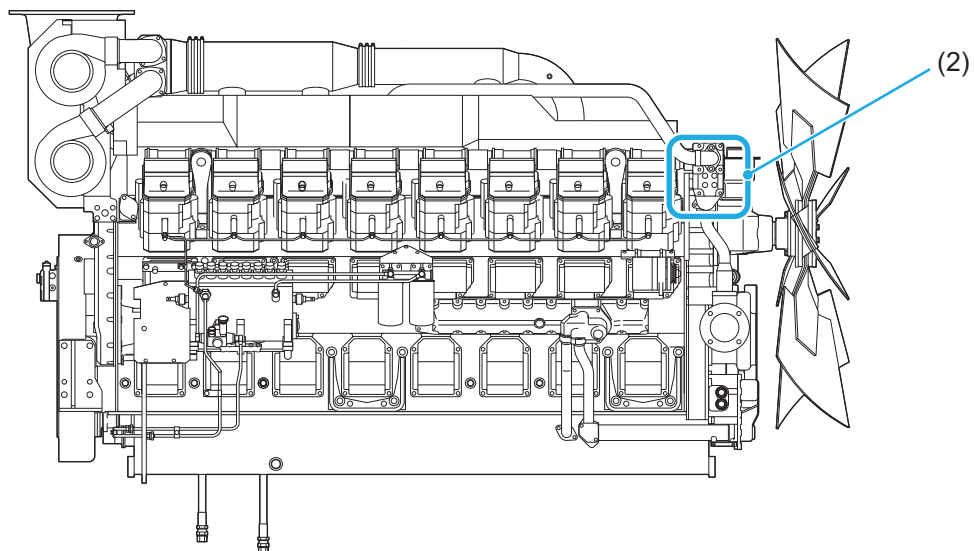

■ Left Side View

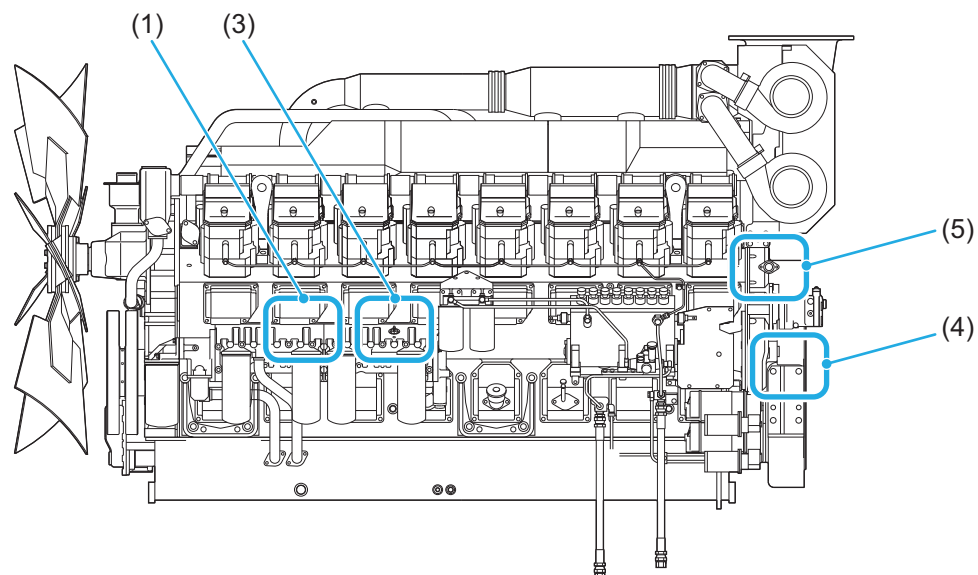

No.	Name
(1)	Oil pressure switch
(2)	Thermo switch
(3)	Oil filter alarm switch

No.	Name
(4)	Rotation detection pickup
(5)	Manual stop lever

S16R-Y1PTAA2, S16R-Y1PTAA2-1, S16R-Y1PTAA2-3

■ Right Side View

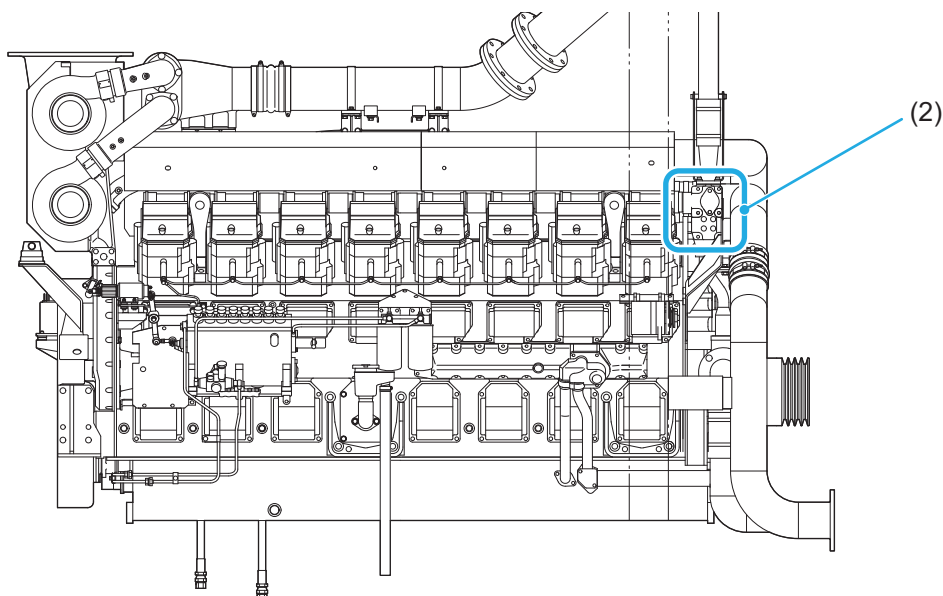

■ Left Side View

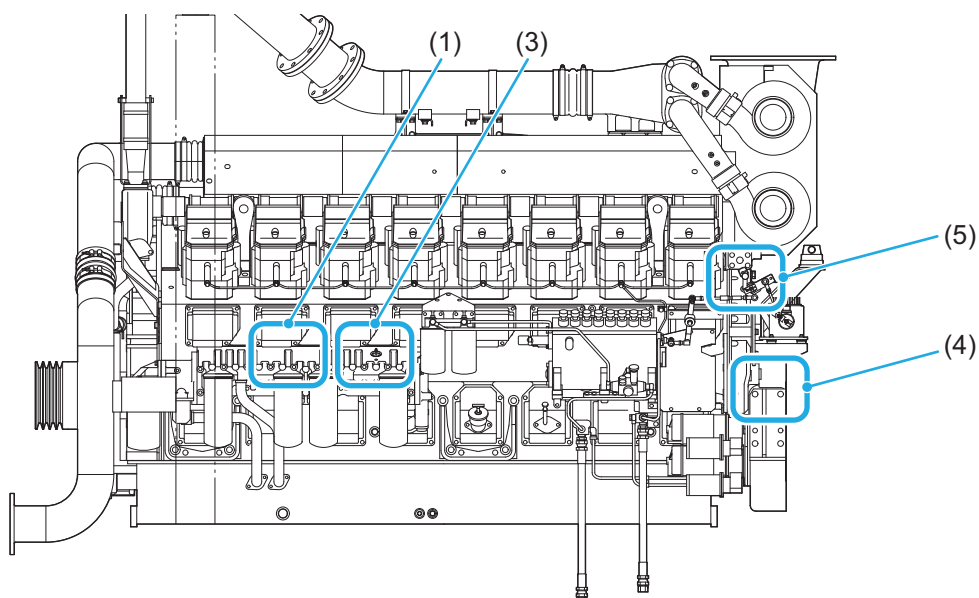

No.	Name
(1)	Oil pressure switch
(2)	Thermo switch
(3)	Oil filter alarm switch

No.	Name
(4)	Rotation detection pickup
(5)	Manual stop lever

S16R-Y2PTAW, S16R-Y2PTAW-1, S16R-Y2PTAW2, S16R-Y2PTAW2-1

■ Right Side View

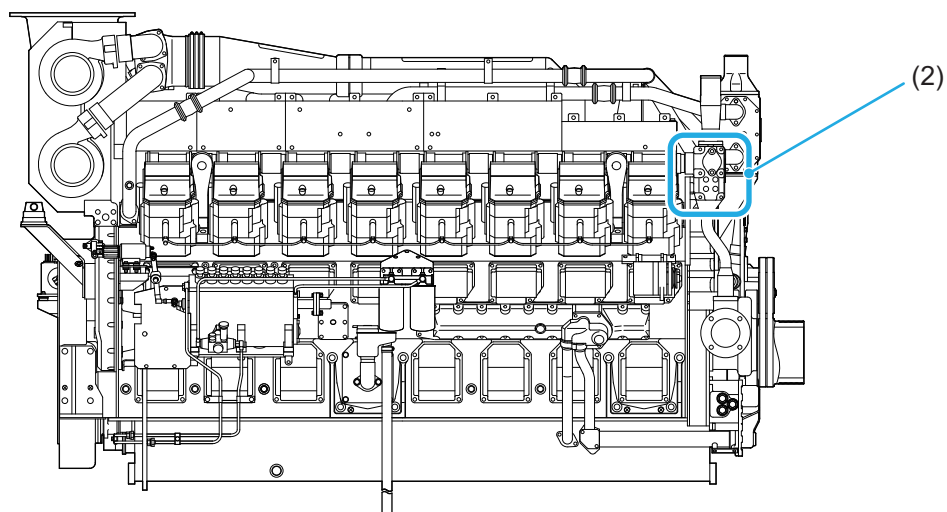

■ Left Side View

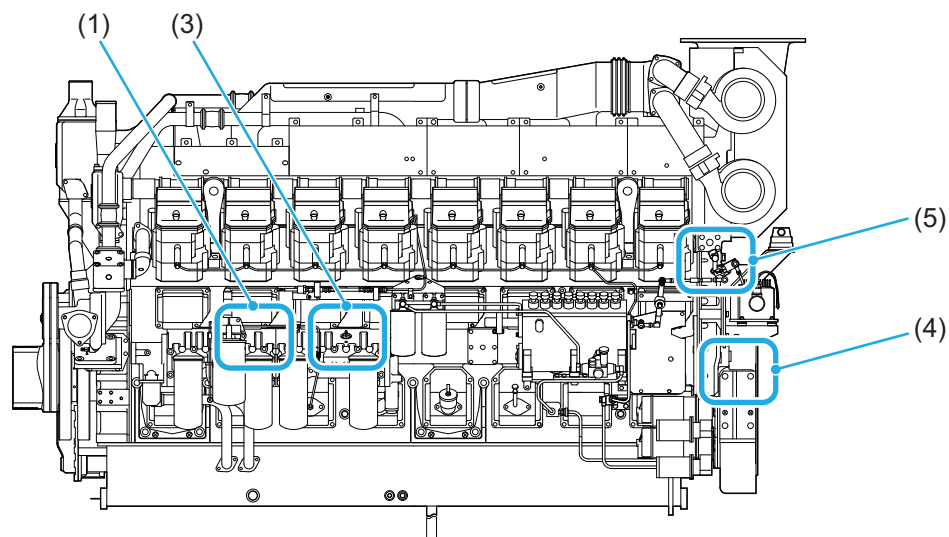

No.	Name
(1)	Oil pressure switch
(2)	Thermo switch
(3)	Oil filter alarm switch

No.	Name
(4)	Rotation detection pickup
(5)	Manual stop lever

Starting and Stopping Devices Installed during Manufacturing the Generator

Compile the information about the starting and stopping devices as well as operation panels installed during manufacturing the generator and attach it below.

Also ensure that their locations and function are instructed to, and understood by the operators in addition to the details of the "Safety Manual".

Please compile the information about the starting and stopping devices as well as operation panels installed during manufacturing the generator and attach it on this page.

3 OPERATION

This chapter describes the operation procedures.

Operation - Outline

The method of operation depends on the intended use and starting system of the engine.

Refer to "[SPECIFICATIONS - CHECK](#)" (→ [Page 12](#)), and check the intended use and starting system previously.

The flow of operation is as shown in the diagram below.

<Intended Use>

Continuous :Continuous Use Engine

Emergency :Emergency Use Engine

<Starting System>

Common :Common to All Starting Systems

Self starter :Self Starter Motor Starting

Air direct :Air Direct Admission Starting

Air motor :Air Motor Starting

1 Daily Check

Continuous **Emergency** **Common**

- Operational Environment - Check
- Engine Exterior - Check

2 Pre-operation Check

Continuous **Emergency**

- Fuel Tank Oil Level - Check **Common**
- Fuel Control Link - Check **Common**
- Engine Oil Level - Check **Common**
- Coolant Level - Check **Common**
- Battery - Check **Common**
- Pre-cleaner - Check for Clogging **Common**
- Air Cleaner - Check for Clogging **Common**
- Damper Temperature - Check **Common**
- Manual Turning Gear - Check **Common**
- Air Direct Admission Starting - Check **Air direct**
- Air Motor Starting - Check **Air motor**

3 Engine Start-up **Continuous** **Emergency**

- Self Starter Motor Starting **Self starter**
- Air Direct Admission Starting **Air direct**
- Air Motor Starting **Air motor**

4 Warm-up Operation

Continuous **Emergency** **Common**

5 Operation

Continuous **Emergency** **Common**

- Checking during Operation

6 Cooling Operation

Continuous **Emergency** **Common**

7 Stopping

Continuous **Emergency** **Common**

8 Checking after Stopping

Continuous **Emergency** **Common**

Maintenance Operation

Continuous **Emergency** **Common**

Daily Check

Check the following items everyday, even when the engine is not started.

Note

- **Devices and equipment outside the scope of our supply are included in the facility.**
For the details, refer to such a document as the specifications sheet prepared by the generator manufacturer.
- **For the devices and equipment outside the scope of our supply, refer the corresponding manual of the generator and the supplier's operation manual.**

Operational Environment - Check

⚠ WARNING



Do not operate in an environment below the lower limit of the ambient temperature specified in the specifications sheet.

- * Otherwise, flue explosion may occur, which could cause serious personal injury or damage to the devices.
- * When operating in an environment below the lower limit of the ambient temperature, it is necessary to install an additional water heater.

Do not operate in an environment above the upper limit of the ambient temperature specified in the specifications sheet.

- * A violation of the law related to the devices could result.
- * Damage to the engine due to overheat or worsen exhaust values will result.
- * When operating in an environment above the upper limit of the ambient temperature, it is necessary to reexamine the operating conditions and operating time.

Keep away from fire, when working with flammable substances such as fuel, engine oil, coolant (LLC), grease, rust preventive oil and anti-corrosive agent.

- * They could cause a fire.

Do not place flammable substances such as fuel and engine oil around the engine.

- * They could cause a fire.

⚠ WARNING



Make sure that there is no water (especially, seawater or rain water) seeped in the air intake and exhaust ports.

- * Piston scuffing (contact of the piston with the cylinder inner wall) and damage to the devices could result.

Make sure that no foreign particles get into the air inlet.

- * They could cause damage to the turbocharger and lead to serious problems in the engine.

Make sure that there is no contamination of water into the fuel, engine oil, air inlet and exhaust systems and combustion chambers.

- * Flue explosion, deterioration in the exhaust gas properties or damage to the devices could result.

Make sure that there is no clogging in the air cleaner or pre-cleaner.

- * Otherwise, the engine stopping device will work to stop the engine suddenly and cause deterioration in the exhaust gas properties.

Make sure that there is no clogging in the air cleaner element or pre-cleaner element.

- * The thermal load could increase excessively and will cause piston scuffing.

Before maintaining electrical components, place the battery switch to the OFF position or disconnect the battery negative (-) terminal.

- * Electric shock could result when electricity flows through the circuit.

Be sure to operate the engine in an environment of appropriate humidity.

- * High humidity, inrush of rain water, or water condensation in the combustion chamber may cause falling off of valves or water hammering and lead to damage to the devices.

⚠ CAUTION

Before starting the engine, check that there are no bolts, nuts, tools, etc. around the rotating parts.

* When the rotating parts work, the above objects can fly and cause personal injury or damage to the surrounding.

* Entanglement in rotating parts could cause machine damage.

Check that the terminals and connectors of the electrical system are connected correctly.

* Otherwise, starting failure or overrun due to inability to stop the engine could occur.

Note

- **Obey the environmental requirements such as ambient temperature and humidity specified in the contract specifications. Otherwise, overheat or overcooling may occur. In case of overheat or overcooling, contact your MHIET dealer "[CONTACT LIST](#)" (→ [Page 10](#)).**
- **Do not install the engine in the following places:**
 - **In a dusty place**
 - **In an atmosphere of inflammable gas**
 - **In a place where salt damage may occur**

Otherwise, a fire or damage to the devices may occur.
- **Operating the engine in an environment exposed to strong electromagnetic fields may cause uncontrollability or overrun of the engine due to the malfunction of the electronic governor. When operating the engine in an environment possibly exposed to strong electromagnetic fields, contact your MHIET dealer "[CONTACT LIST](#)" (→ [Page 10](#)).**

Make sure the following measures are taken.

- (a) Air intake port
 - Prevent inrush of water (especially sea water and rainwater)
 - Prevent contamination by foreign materials
- (b) Rotating parts
 - Prevent contamination by foreign materials
 - Prevent contact with human body (install a protective cover)
- (c) Hot parts
 - Prevent contact with human body (confirm warning labels)
- (d) Electrical system
 - Prevent adhesion of water and dust
- (e) Ambient temperature
 - Keep in the range between 5 and 40°C [41 and 104°F]
- (f) Coolant temperature
 - Control properly
- (g) Additional equipment of generator (water heater etc.)
 - Control properly

Engine Exterior - Check

⚠ WARNING



Make sure that any accumulation of flammables, fuel leaks, engine oil leaks, moisture, etc. are not found around the hot parts of the engine (exhaust manifold) and the battery.

* They could cause a fire.

Make sure that a coolant leak from any part of the engine is not found.

* Coolant will flow out.

Make sure that the open/close conditions of the valves, plugs and cocks on each line are normal.

* Otherwise, the engine may seize.

Make sure that the open/close condition of the coolant drain cock on the water pump is normal.

* Otherwise, insufficient cooling could occur and it could cause serious damage to the devices.

Make sure that the engine oil leak from any part of the engine is not found.

* If engine oil gets in your eyes, it will cause pain and lead to sight loss at the worst.

⚠ CAUTION



Before starting the engine, check the battery and cable terminals for corrosion. In addition, check the connections for looseness.

* Defective contact or short circuit could cause damage to the devices.

1 Check combustible materials near the engine or battery.

→If combustible materials or dust are found near the engine or battery, remove them.

2 Check the engine and battery for contamination.

→If dirty, clean them.

3 Check a leak of fuel, engine oil, or coolant from any part of the engine.

Note

- If a leak is found, contact your MHIET dealer "[CONTACT LIST](#)" (→ [Page 10](#)) to arrange the repair.

4 Check the alternator belt tension. "[Belt - Check](#)" (→ [Page 127](#))

5 Check bolts and nuts for looseness from the outside.

6 Check the battery and cable terminals and connections for corrosion or looseness.

Note

- If an abnormality is found, consult your MHIET dealer "[CONTACT LIST](#)" (→ [Page 10](#)).

7 Check the following open/close conditions.

- Fuel feed valve: open
- Coolant drain cock (plug): closed
- Engine oil drain valve: closed

Pre-operation Check

⚠ WARNING



Be sure to perform the pre-operation check and scheduled maintenance as instructed in this Operation & Maintenance Manual.

* Failure to perform the pre-operation check and scheduled maintenance may cause various engine problems and breakage to parts, which may result in serious accidents.

Before starting the engine, make sure the protective covers of the engine are correctly installed.

* If you are caught in rotating parts, you could be seriously injured.

Before starting the engine, be sure to always perform the check mentioned below.

Note

- **Devices and equipment outside the scope of our supply are included in the facility.**
For the details, refer to such a document as the specifications sheet prepared by the generator manufacturer.
- **For the devices and equipment outside the scope of our supply, refer the corresponding manual of the generator and the supplier's operation manual.**

Fuel Tank Oil Level - Check

⚠ WARNING



When discarding a waste cloth used to wipe off combustible material, put it into a lidded can and obey the Waste Management and Public Cleansing Act to handle it as a special industrial waste.

- * It may cause a fire.
- * It could lead to environmental pollution.
- * If you violate rules, you may be subject to penalties.

Before handling fuel, remove static electricity.

- * Otherwise, the fuel could be ignited.
- * Ground the fuel tank.

⚠ CAUTION



Do not remove the strainer while filling the fuel tank.

- * Otherwise, foreign particles could enter and cause damage to the fuel pump.

Note

- **When handling fuel, refer to "[4 FUEL](#)" (→ [Page 104](#)).**
- **The fuel tank is outside the scope of our supply. For the details, refer to such a document as the corresponding manual of the generator and the supplier's operation manual.**

- 1 **Check the fuel tank oil level.**
- 2 **Refuel the fuel tank to the upper limit of the specified quantity.**

Fuel Control Link - Check

Refer to "[Fuel Control Link - Check](#)" (→ [Page 142](#)).

Engine Oil Level - Check

Refer to "[Engine Oil Level - Check](#)" (→ [Page 149](#)).

Note

- **When handling engine oil, refer to "[5 ENGINE OIL](#)" (→ [Page 110](#)).**

Coolant Level - Check

DANGER



Use the genuine LLC specified in this Operation & Maintenance Manual.

* Otherwise, the devices could be damaged.

Keep LLC to be the specified concentration.

- * If LLC concentration is low, it could cause corrosion of the radiator or heat exchanger.
- * If LLC concentration is high, it may cause damage to the devices or overheat due to the seized engine parts.

WARNING



Do not open the radiator cap or coolant tank cap while the engine is hot.

* Otherwise, you could get burns by steam or water splashing out.



Tighten the drain cock on the water pump properly.

* Insufficient tightening may cause a coolant leak.

When handling coolant (LLC), always wear suitable personal protective equipment such as rubber gloves and protective eyeglasses.

- * If LLC comes into contact with your eyes, it will result in sight loss at the worst.
- * If LLC comes into contact with your skin while the engine is hot, you could get burned by heat.

Maintain the coolant level properly.

* If the coolant level is low, overheat or cavitation in the engine could occur.

Check the coolant level.

- If the level is low, refill the coolant. ["Coolant - Refill"](#) (→ Page 161)
- After refilling the coolant level, bleed air from the cooling system. ["Cooling System - Bleed Air"](#) (→ Page 162)

Note

- **When handling coolant, refer to "[6 COOLANT](#)" (→ Page 112).**
- **For how to check the coolant level, refer to the corresponding manual of the generator and the supplier's operation manual.**
- **For the specified quantity of coolant, refer to "[SPECIFICATIONS - CHECK](#)" (→ Page 12).**

Battery - Check

WARNING



Do not short the battery terminals.

* Otherwise, sparks could occur and cause a fire or an explosion.

Do not touch battery terminal with a wet hand.

* There are possibilities to get an electric shock.



When checking and servicing the battery, wear suitable personal protective equipment such as protective eyeglasses, rubber gloves, working clothes with long sleeves and long trousers.

* If battery fluid comes into contact with your eyes or skin, it may result in sight loss or burns.

Note

- **The battery is outside the scope of our supply. For the details, refer to such a document as the corresponding manual of the generator and the supplier's operation manual.**

1 Check the battery fluid level.

- Refill the battery fluid, if necessary.

2 Check the battery fluid specific gravity.

- Charge the battery, if necessary.

Pre-cleaner - Check for Clogging

⚠ WARNING

! Make sure that the pre-cleaner is free from clogging.

* Insufficient intake air could result in loss of power, incomplete combustion, exhaust gas temperature rise, and overspeed of the turbocharger.

Check the pre-cleaner for clogging.

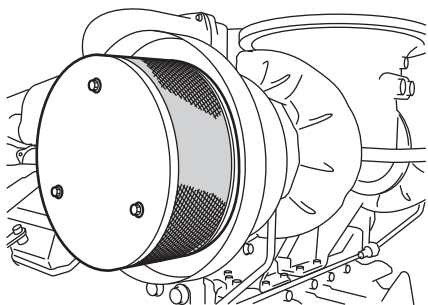

Fig. 3-1 Pre-cleaner - Check for Clogging

Air Cleaner - Check for Clogging

⚠ WARNING

! Make sure that the air cleaner is free from clogging.

* Insufficient intake air could result in loss of power, incomplete combustion, exhaust gas temperature rise, and overspeed of the turbocharger.

Check the air cleaner for clogging.

Note

- **The air cleaner may be outside the scope of our supply. For the details, refer to such a document as the specification sheet prepared by the generator manufacturer.**
- **If it is not supplied by MHIET, follow the instructions in the supplier's operation manual.**

Damper Temperature - Check

⚠ WARNING

! Make sure that the damper temperature is within the permissible range (for continuous use: **90°C [194°F] or less; for emergency use: 100°C [212°F] or less**).

* Degradation of silicone oil could result in a loss of damping and breakage of the crankshaft.

On the damper, a thermo label is attached as a guide.

Check the temperature by using the thermo label as follows:

Note

- **For the location of the dampers, refer to "2 ENGINE - OUTLINE" (→ Page 76).**

1 Check the heat-sensitive area of the thermo label and record the highest temperature.

→If a temperature rise is observed, locate the defect in the engine or other causes. In addition, replace the thermo label with a new one and check the change of temperature again. ["Damper Temperature - Check" \(→ Page 132\)](#)

Note

- **A thermo label is attached as a guide. It is recommended to measure the temperature while operating the engine with a noncontact thermometer (thermo gun) and to control and record it accordingly.**
- **If the detected temperature comes close to the limit temperature of the damper as shown in the table below, or if there is any abnormal change of temperature, contact your MHIET dealer ["CONTACT LIST" \(→ Page 10\)](#).**

Table 3-1 Limit Temperature of Damper

Type of damper	Continuous use engine	Emergency use engine
Viscous damper	90°C [194°F]	100°C [212°F]

Manual Turning Gear - Check

⚠ DANGER

! Before starting the engine, pull out the manual turning gear shaft.

* Starting the engine while the turning gear is engaged with the ring gear could result in serious personal injury or destruction of the engine.

⚠ WARNING

! Make sure that the plate of the manual turning gear is securely engaged in the shaft groove.

* Otherwise, the devices could be damaged.

Check whether the manual turning gear is pulled out.

Note

- For the location of the manual turning gear, refer to "[2 ENGINE - OUTLINE](#)" (→ [Page 76](#)).

- 1 Check that the manual turning gear shaft (1) is pulled out and fixed by the plate (2).

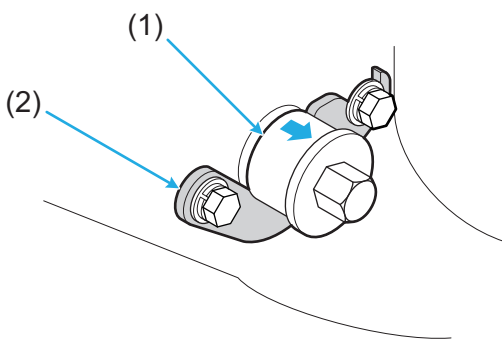

Fig. 3-2 Manual Turning Gear - Check

Air Direct Admission Starting - Check

■ Starting Air Tank - Check

⚠ WARNING

! Be sure to drain water from the starting air tank.

* Otherwise, water could enter the cylinders when starting the engine.

Drain water from the starting air tank and check the air pressure.

Note

- The starting air tank may be outside the scope of our supply. For the details, refer to such a document as the specification sheet prepared by the generator manufacturer.
- If it is not supplied by MHIET, follow the instructions in the supplier's operation manual.

■ Starting Air Compressor - Check

Check the starting air compressor.

Note

- The starting air compressor may be outside the scope of our supply. For the details, refer to such a document as the specification sheet prepared by the generator manufacturer.
- If it is not supplied by MHIET, follow the instructions in the supplier's operation manual.

■ Air Filter - Check

Check the air filter.

Note

- The air filter may be outside the scope of our supply. For the details, refer to such a document as the specification sheet prepared by the generator manufacturer.
- If it is not supplied by MHIET, follow the instructions in the supplier's operation manual.

■ Starting Valve - Check

Check the starting valve.

Note

- **The starting valve may be outside the scope of our supply. For the details, refer to such a document as the specification sheet prepared by the generator manufacturer.**
- **If it is not supplied by MHIET, follow the instructions in the supplier's operation manual.**

Air Motor Starting - Check

■ Starting Air Tank - Check

⚠ WARNING



Make sure that the air pressure in the starting air tank satisfies the specification.

* If starting is attempted several times in a row, the air motor could get damaged.

⚠ CAUTION



Be sure to drain water from the starting air tank.

* Otherwise, water could enter the air motor when starting the engine.

Drain water from the starting air tank and check the air pressure.

Note

- **The starting air tank may be outside the scope of our supply. For the details, refer to such a document as the specification sheet prepared by the generator manufacturer.**
- **If it is not supplied by MHIET, follow the instructions in the supplier's operation manual.**

■ Starting Air Compressor - Check

Check the starting air compressor.

Note

- **The starting air compressor may be outside the scope of our supply. For the details, refer to such a document as the specification sheet prepared by the generator manufacturer.**
- **If it is not supplied by MHIET, follow the instructions in the supplier's operation manual.**

■ Air Filter - Check

Check the air filter.

Note

- **The air filter may be outside the scope of our supply. For the details, refer to such a document as the specification sheet prepared by the generator manufacturer.**
- **If it is not supplied by MHIET, follow the instructions in the supplier's operation manual.**

■ Reducing Valve - Check

Check the reducing valve.

Note

- **The reducing valve may be outside the scope of our supply. For the details, refer to such a document as the specification sheet prepared by the generator manufacturer.**
- **If it is not supplied by MHIET, follow the instructions in the supplier's operation manual.**

■ Lubricator - Check

Check the lubricator.

Note

- **The lubricator may be outside the scope of our supply. For the details, refer to such a document as the specification sheet prepared by the generator manufacturer.**
- **If it is not supplied by MHIET, follow the instructions in the supplier's operation manual.**

Engine Start-up

⚠ WARNING



Do not apply load to the engine at startup.

* Otherwise, the devices could be damaged.

Do not use the starter continuously for 10 seconds or longer. In case that the engine does not start after three consecutive trials, contact your MHIET dealer.

* Otherwise, flue explosion due to the accumulation of unburnt fuel or burn-damage to the starter may occur.

While a warning sign such as "DO NOT OPERATE" is hanged out on the starting system, do not start the engine.

* Otherwise, serious personal injury, environmental pollution or damage to the devices could occur.

Do not start the engine with water inside its combustion chamber.

* Otherwise, water hammering could cause damage to the engine inner parts and a serious accident.



Before starting the engine, make sure there is no one in the vicinity of the engine.

* Otherwise, he/she may be caught in the rotating parts and get seriously injured or suffer noise-induced hearing loss.

Note

- **Devices and equipment outside the scope of our supply are included in the facility. For the details, refer to such a document as the specifications sheet prepared by the generator manufacturer.**
- **For the devices and equipment outside the scope of our supply, refer the corresponding manual of the generator and the supplier's operation manual.**

Self Starter Motor Starting

A general starting procedure is as follows:

Note

- **The engine start switch is outside the scope of our supply. For the details, refer to such a document as the corresponding manual of the generator and the supplier's operation manual.**

- 1 **Operate the start switch of the generator ["Starting and Stopping Devices Installed during Manufacturing the Generator"](#) (→ [Page 87](#)) to start the engine.**

Air Direct Admission Starting

A general starting procedure is as follows:

Note

- **The starting air tank and starting system may be outside the scope of our supply. For the details, refer to such a document as the specification sheet prepared by the generator manufacturer.**
- **If it is not supplied by MHIET, follow the instructions in the supplier's operation manual.**

- 1 **Check the air pressure gauge to see if the air pressure in the starting air tank satisfies the specification.**
- 2 **Open the main valve of the starting air tank.**
- 3 **Operate the start switch of the generator ["Starting and Stopping Devices Installed during Manufacturing the Generator"](#) (→ [Page 87](#)) to start the engine.**
→If the engine doesn't start, check the points below and reset the pressure in the starting air tank. Restart the engine after 2 minutes interval.
 - Is the air pressure gauge in order?
 - Is a leak found from the air system?

Note

- In case there is an abnormality or the engine does not start after three consecutive trials, contact your MHIET dealer "[CONTACT LIST](#)" (→ [Page 10](#)).

- 4 After the engine has started, close the main valve of starting air tank.

Air Motor Starting

A general starting procedure is as follows:

Note

- The starting air tank and starting system may be outside the scope of our supply. For the details, refer to such a document as the specification sheet prepared by the generator manufacturer.
- If it is not supplied by MHIET, follow the instructions in the supplier's operation manual.

- 1 Check the air pressure gauge to see if the air pressure in the starting air tank satisfies the specification.
- 2 Open the main valve of the starting air tank.

- 3 Operate the start switch of the generator "[Starting and Stopping Devices Installed during Manufacturing the Generator](#)" (→ [Page 87](#)) to start the engine.

→If the engine doesn't start, check the points below and reset the pressure in the starting air tank. Restart the engine after 2 minutes interval.

- Is the air pressure gauge in order?
- Is a leak found from the air system?
- Does too much oil flow out of the air motor muffler (1)?

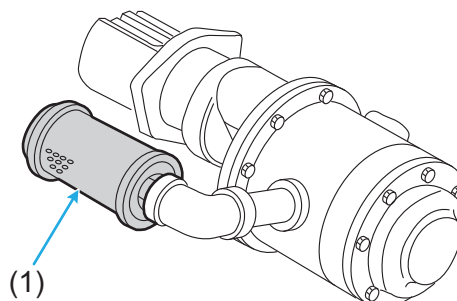

Fig. 3-3 Air Motor Muffler

Note

- In case there is an abnormality or the engine does not start after three consecutive trials, contact your MHIET dealer "[CONTACT LIST](#)" (→ [Page 10](#)).

- 4 After the engine has started, close the main valve of starting air tank.

Warm-up Operation

WARNING



Stay away from rotating parts during operation.

- * Otherwise you may get caught in the rotating parts and seriously injured.

Do not apply excessive load when the engine is cold.

- * Otherwise, it could cause a failure.
- * If the engine is driven at an idle speed in the low load range for a prolonged period of time, unburnt fuel may accumulate in the flue and explode.



Allowable minimum load during continuous operation: Operate with 30% or more of the rated output. Allowable continuous operation time with a load factor of 30% or less of the rated output: Limit the operation within one hour.

Operate with a load factor of 50% or more for 30 minutes or more after continuous operation with 30% or less of the rated output is conducted.

The following problems may occur when light load operation is conducted beyond the above allowable range:

- * Fuel and/or oil leak from the exhaust system
- * Carbon build-up on the cylinder head and exhaust pipe
- * Sulfuric acid corrosion
- * Dilution
- * Generation of blue-white smoke (mainly during low idle operation)

While the engine is warming up, check the connections for leak (fuel, engine oil, coolant and exhaust gas). If an abnormality is found, stop the engine immediately.

- * Otherwise, a fire or damage to the devices may occur.
- * It could lead to carbon monoxide intoxication or environmental pollution.

Applying an excessive load when the engine is cold may cause failure. Be sure to warm up the engine according to the operating guidelines of the generator.

1 Warm up the engine according to the starting sequence of the generator.

- When warming up the engine by setting particularly, operate it at no load and idle speed.

2 Check the engine oil pressure with the oil pressure gauge.

- Standard value: 0.3 MPa {3.06 kgf/cm²} [43.51 psi] or more

3 Check the connections for a leak of fuel, engine oil, coolant and exhaust gas.

- Check around the engine thoroughly.

Note

- **If a leak is found, stop the engine and contact your MHIET dealer "[CONTACT LIST](#)" (→ [Page 10](#)).**

Operation

WARNING



Stay away from rotating parts during operation.

- * Otherwise you may get caught in the rotating parts and seriously injured.

Do not approach the engine side without care during operation.

- * Serious injury may result due to unexpected device operation.

Do not touch any part of the engine (other than the manual stop lever) during or immediately after operation and immediately after stopping.

- * If you touch, you could get burned by heat.
- * Before starting the inspection and maintenance work, make sure that the engine is cooled down.

Do not turn off the battery switch during operation.

- * Otherwise, the instruments will become inoperable, damage to the devices due to operation at low oil pressure may occur, the engine may be forcibly stopped by the solenoids, or the engine may become unable to stop.
- * It may also cause degradation of the diodes and transistors in the alternator.

Never turn the key to the "START" position during operation.

- * Otherwise, the starter could be damaged.

Do not remove the protective covers during operation.

- * If you are caught in rotating parts, you could be seriously injured.

Do not perform the inspection and maintenance work during operation.

- * Unexpected activation of the devices could cause serious personal injury or damage to the devices.

Do not clean the engine during operation.

- * Otherwise, water or cleaning solution could enter the engine, and will cause piston scuffing and damage to the devices.

Do not operate the engine at no load or low load for a prolonged period of time.

- * Otherwise, it could cause deterioration in the exhaust gas properties.

WARNING



Do not operate the engine at a load exceeding the specified value or for a prolonged period of time.

- * Otherwise, the main bearing or connecting rod bearing could seize.
- * The thermal load could increase excessively and will cause piston scuffing.
- * Otherwise, the crankshaft stress could become too large, and the crankshaft could crack or break.

Do not approach near the breather or breather gas.

- * The breather releases breather gas in the air. Contacting the breather gas may cause burns.



Ventilate the machine room (engine room) sufficiently.

- * Otherwise, deterioration in the exhaust gas properties and damage to the devices could occur due to insufficient air intake.

Allowable minimum load during continuous operation: Operate with 30% or more of the rated output. Allowable continuous operation time with a load factor of 30% or less of the rated output: Limit the operation within one hour.

Operate with a load factor of 50% or more for 30 minutes or more after continuous operation with 30% or less of the rated output is conducted.

The following problems may occur when light load operation is conducted beyond the above allowable range:

- * Fuel and/or oil leak from the exhaust system
- * Carbon build-up on the cylinder head and exhaust pipe
- * Sulfuric acid corrosion
- * Dilution
- * Generation of blue-white smoke (mainly during low idle operation)

Be sure to start the engine according to the operating guidelines of the generator.

Operate with a load factor of 50% or more for 30 minutes or more after continuous operation with 30% or less of the rated output is conducted.

Note

- **Devices and equipment outside the scope of our supply are included in the facility. For the details, refer to such a document as the specifications sheet prepared by the generator manufacturer.**
- **For the devices and equipment outside the scope of our supply, refer the corresponding manual of the generator and the supplier's operation manual.**

Checking during Operation

⚠ WARNING



If an engine abnormality is observed during operation, stop the engine immediately.

- * Use of the engine without any remedy could cause serious personal injury or damage to the devices.
- * Investigate the cause of abnormality, correct the defect, then restart the engine.
- * If the cause of problem cannot be located, contact your MHIET dealer.

If overload symptoms such as black exhaust smoke is observed, reduce the load immediately and assure the proper output.

- * Overload could not only cause increase in fuel consumption but also lead to malfunction and environmental pollution (outbreak of the black smoke) due to carbon deposits.

Check exhaust pipes and pipe joints for exhaust gas leaks.

- * Otherwise, it may cause carbon monoxide intoxication and lead to death at the worst.
- * If an exhaust leak is found, contact your MHIET dealer.

If an abnormal engine oil pressure drop is observed, stop the engine immediately, and check the engine oil system to locate the cause.

- * Use of the engine without any remedy could cause seizure of the bearings and lead to serious damage to the devices.
- * If the cause of problem cannot be located, contact your MHIET dealer.

If a belt breaks, stop the engine immediately and replace the belt.

- * Use of the engine without any remedy could cause defective battery charge and cooling fault, and result in serious engine problems.

⚠ CAUTION



Keep the intake air temperature at the specified level.

- * If the intake air temperature is higher than the specified level, the engine stopping device may work due to the increased exhaust temperature and stop the engine suddenly.
- * The thermal load could increase excessively and will cause piston scuffing.
- * If the intake air temperature cannot be kept at the specified level, reconsider the operating conditions and operating time.

Keep the engine oil and coolant temperatures at the specified level.

- * If the engine oil or coolant temperatures is increased, the engine stopping device may work due to the increased exhaust temperature and stop the engine suddenly.

During engine operation, check engine for abnormal noise and vibrations due to knocking, and leaks from pipes.

Also carefully check the followings for abnormalities.

Table 3-2 Checking During Operation

Check item	Criteria/Reference Value
Warning indicator/instruments	Lighting/numerical value normality
Engine speed/frequency	No large fluctuation
Breather mist volume	To be normal
Exhaust color	To be normal
Damper temperature*	For continuous use: 90°C [194°F] or less For emergency use: 100°C [212°F] or less
Engine oil pressure	0.39 MPa {3.98 kgf/cm ² } [56.56 psi] or more
Engine oil temperature (Oil pan)	110°C [230°F] or less
Coolant temperature	70 to 90 °C [158 to 194°F] (in the water jacket)
Exhaust temperature	550°C [1022°F] or less
Intake air pressure	0.15 to 0.25 MPa {1.53 to 2.55 kgf/cm ² } [21.76 to 36.26 psi]

*: Check, control and record the temperature change during operation. Checking by means of a noncontact thermometer (thermo gun) is recommended.

Note

- **If any abnormality is found, refer to "[11 TROUBLESHOOTING](#)" (→ [Page 179](#)) and correct the defect.**

Cooling Operation

⚠ WARNING



Except in a time of emergency, operate the engine at low idle for 5 to 6 minutes to cool down before stopping the engine.

* If the engine is stopped without cooling down, the devices could be damaged.

⚠ CAUTION



Do not stop the engine suddenly at high speed.

* It could cause damage to the devices due to degradation of the damper or stopped circulation of the engine oil to the turbocharger.

Stopping the engine suddenly at high speed or high load could cause a malfunction.

Be sure to cool down the engine according to the operating guidelines of the generator.

1 Cool down the engine according to the stopping sequence of the generator.

- When cooling down the engine by setting particularly, operate it for 5 to 6 minutes at an idle speed.

Stopping

⚠ WARNING



Do not restart the engine immediately after an abnormal stop.

* Investigate the cause of abnormality, correct the defect, then restart the engine.

Do not race the engine immediately before shutting it down.

* Otherwise, the devices could be damaged.

Be sure to stop the engine as per the operating guidelines of the generator.

- 1 **Operate the stop switch of the generator** ["Starting and Stopping Devices Installed during Manufacturing the Generator"](#) (→ [Page 87](#)) **to turn off the engine.**

Note

- **If the engine will not stop, perform an emergency stop by means of the manual stop lever of the engine.** ["Emergency Stop Procedure"](#) (→ [Page 66](#))

Checking after Stopping

Check that a fuel, oil or coolant leak from any part of the engine is not found after the engine is stopped.

Note

- **In case of an unallocated defective point or leakage, contact your MHIET dealer** ["CONTACT LIST"](#) (→ [Page 10](#)).

Maintenance Operation

In order to ensure performance of the engine, perform maintenance operation regularly, in case that both of the engines for continuous use and emergency use will not be used for a long time.

Note

- **For the generator set of emergency use, maintenance operation and/or the report according to the Electric Utilities Industry Law, Fire Services Law, or Building Standard Law etc. is obliged according to the generator set application.**
- **The method of inspection and maintenance, and maintenance operation differs according to the device. Contact the device supplier.**

■ Once a Week

Operate the engine for 5 to 10 minutes at no load and check the following points:

- Startability, exhaust color
- Abnormal vibration, noise and odor
- Indication of various instruments (oil pressure gauge, water temperature gauge, oil temperature gauge, exhaust temperature gauge, tachometer, etc.)

Note

- **If any abnormality is found, refer to** ["11 TROUBLESHOOTING"](#) (→ [Page 179](#)) **and correct the defect.**

■ Once a Month

Operate the engine at least for 30 minutes at 50% load or more and check the following points:

- Startability, exhaust color
- Abnormal vibration, noise and odor
- Indication of various instruments (oil pressure gauge, water temperature gauge, oil temperature gauge, exhaust temperature gauge, tachometer, etc.)
- Fuel injection pump and governor rack movement
- Damper temperature and external view

Note

- **If any abnormality is found, refer to** ["11 TROUBLESHOOTING"](#) (→ [Page 179](#)) **and correct the defect.**

4 FUEL

This chapter describes the fuel which is used for this engine.

Fuel

⚠ WARNING



Do not refill the fuel tank more than the specified level.

* Otherwise, fuel will leak out and may cause a fire.

Do not mix and use fuels of different types and/or manufacturers.

* Otherwise, damage to the fuel supply pump or deterioration in the exhaust gas properties may occur.

Do not use fuel after the recommended storage expiration date.

* Otherwise, incomplete combustion may occur, which could result in flue explosion or deterioration in the exhaust gas properties.



Use only the fuel that meets our fuel quality standards specified in this Operation & Maintenance Manual.

* Otherwise, damage to the fuel supply pump or deterioration in the exhaust gas properties may occur.

* Using a fuel with low cetane number (lower than 45) may result in flue explosion.

Change the fuel remained in the tank or the pipelines over the period recommended by the manufacturer with new fuel.

* Otherwise, deterioration in the components may cause clogged pipe lines, which could result in starting failure.

Note

- **Use a fuel which meets the requirements specified in "[Fuel Quality Standard](#)" (→ [Page 107](#)).**

Do not mix and use fuels of different types and/or manufacturers.

Diesel Fuel (Emission Control Approved Model)

Please check if the engine in use is an emission control approved model which obtained the certificate of EPA or CARB regulations of United States.

- Nameplate
["MODEL NAME"](#) (→ [Page 11](#))
- Emission control approved label
["EMISSION CONTROL APPROVAL LABEL"](#) (→ [Page 14](#))
- List of models
["LIST OF MODELS"](#) (→ [Page 19](#))

⚠ WARNING



Do not mix any poor-quality fuel, water extracting agent, fuel additive, gasoline, kerosine, or alcohol-based fuel.

* It could cause fuel filter clogging, sliding fault on the fuel lubricated part in fuel injector, and adverse effect to the engine, and will lead to an engine trouble.



Be sure to use Ultra-Low-Sulfur Diesel (ULSD) for the emission control approved model engine.

* If not used, there is a risk that the engine cannot conform to the emission control regulation of Environmental Protection Agency (EPA) of United States.

Be sure to use Ultra-Low-Sulfur Diesel (ULSD) for the emission control approved model engine.

Select the fuel that meets both specifications in "[Table 4-1 Fuel Properties Table \(Emission Control Approved Model\)](#)" (→ [Page 105](#)) and in "[Table 4-2 Fuel Properties Limit Table](#)" (→ [Page 105](#)).

Table 4-1 Fuel Properties Table (Emission Control Approved Model)

Standard	Classification
ASTM D975	No. 1-D, No. 2-D
JIS K 2204	No. 2
EN 590	DIESEL-FUEL

Table 4-2 Fuel Properties Limit Table

Properties	Limit
Sulfur content	15 ppm or less
Cetane number	45 or more
HFRR	50 μm or less

Attach "DIESEL FUEL ULTRA LOW SULFUR FUEL ONLY" label near the fuel inlet at the fuel tank.

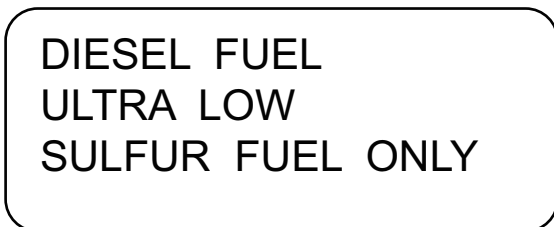

Fig. 4-1 ULSD Label

Diesel Fuel

If the using engine is not an emission control approved model, use the diesel fuel from "[Table 4-3 Fuel Specifications](#)".

Also choose the fuel with the pour point which meets the environmental temperature.

Note

- **Select the fuel used for the engine to conform to the laws and regulations of the country and area where the engine is used.**

Table 4-3 Fuel Specifications

Standard	Classification
ISO 8217	DMX-CLASS
ASTM D975	No. 1-D, No. 2-D
BS 2869	CLASS A1, CLASS A2
DIN 51601	DIESEL-FUEL
JIS K 2204	Special No.1, No.1, No.2, No.3, Special No.3
EN 590	DIESEL-FUEL

Fuel - Handling

⚠ WARNING



Do not discard waste oil into sewerage, river, lake or other similar places.

* Be sure to discard waste oil in accordance with the applicable laws and regulations.

Do not store fuel in a poorly ventilated place.

* Otherwise, vaporized fuel may build up, which could cause an explosion or a fire on exposure to a flame.



Before handling fuel, remove static electricity.

* Otherwise, the fuel could be ignited.
* Ground the fuel tank.

When working with fuel, wear suitable personal protective equipment such as protective mask, protective eyeglasses, rubber gloves, working clothes with long sleeves and long trousers.

* If fuel comes into contact with your eyes, mouth or skin, it will cause irritation or disorders.

Do not breathe in vaporized fuel.

* Otherwise, it could be hazardous to your health.

When storing fuel in the container, close its cap tightly.

* Otherwise, vaporized fuel may build up, which could cause an explosion or a fire on exposure to a flame.

Note

- **Devices and equipment outside the scope of our supply are included in the facility. For the details, refer to such a document as the specifications sheet prepared by the generator manufacturer.**
- **For the devices and equipment outside the scope of our supply, refer the corresponding manual of the generator and the supplier's operation manual.**

Refill the fuel tank or a day tank up to the upper limit of the specified quantity at the end of each operation.

Note

- **By refilling up to the upper limit of the specified quantity, entering of water into the tank can be avoided. In addition, in case that dust or water entered into the tank, a time for separation and precipitation can be given.**

Fuel - Refill

⚠ WARNING



Be sure to drain water from fuel, and pay attention that coolant or other water will not get mixed with fuel.

* Otherwise, rust could form on the plunger, which could interfere engine stopping or cause flue explosion, dilution, or water hammering.

⚠ CAUTION



Do not remove the strainer while filling the fuel tank.

* Otherwise, foreign particles could enter and cause damage to the fuel pump.



When using fuel from a storage tank, leave it to sit for more than 24 hours so that dust and water can settle at the bottom. Then, use the upper clean fuel.

* Otherwise, clogging of the filter may occur, which could cause decrease in the output power.
* Depending on the specification of the tank, prolonged sedimentation time may be required.

- Before removing the cap of a drum can or the tank, clean its surrounding thoroughly. Also clean your hands and hoses.
- When pumping up fuel using a hand-operated pump, be careful not to pump water or sediment accumulated at the bottom of the storage tank.
- When filling the fuel tank, be sure to use a strainer so that foreign particles will not enter.

Fuel Quality Standard

Use a fuel which meets the requirements specified in the table below.

Table 4-4 Fuel Properties Table (1/2)

Item		Recommended limit	Service limit	Remark
Flash point		Diesel fuel 50°C [122°F] or more	50°C [122°F] or more (depending on the laws and regulations for handling fuel)	JIS K 2265 ISO 3679 ISO 2719
Distillation Properties	Initial boiling point	170°C [338°F] or more	170°C [338°F] or more	JIS K 2254 ISO 3405
	90% distillation temperature	330 to 380°C [626 to 716°F]	330 to 380°C [626 to 716°F]	
Pour point (PP)		Lower than ambient temperature by 6°C [10.8°F] or more	Lower than ambient temperature by 6°C [10.8°F] or more	JIS K 2269 ISO 3016
Cloud point (CP)		Ambient temperature or below	Ambient temperature or below	
Cold filter plugging point (CFPP)		Lower than the ambient temperature by 3°C [5.4°F] or more	Lower than the ambient temperature by 3°C [5.4°F] or more	JIS K 2288 ISO 3015
Carbon residue content	10% residual oil	0.4 mass% or less	1.0 mass% or less	JIS K 2270 ISO 6615 ISO 10370
Cetane number		45 or more *1	45 or more *2	JIS K 2280
Cetane Index	(New method)	45 or more	45 or more	ISO 5165 ISO/DIS 4264
Kinetic viscosity		2.0 mm ² /s or more at 30°C [86°F] 8.0 mm ² /s or less at 50°C [122°F]	2.0 mm ² /s or more at 30°C [86°F] 8.0 mm ² /s or less at 50°C [122°F]	JIS K 2283 ISO 3104
Sulfur content		0.2 mass% or less	1.0 mass% or less *2 *3 (Shorten the engine oil change intervals.)	JIS K 2541 (The content amount as low as that of regular light oil is desirable.) ISO 4260 ISO 8754
Water content and sediment		0.1 volume% or less	0.1 volume% or less	JIS K 2275 ISO 3733
Ash content		0.01 mass% or less	0.03 mass% or less	JIS K 2272 ISO 6245
Copper corrosion	50°C [122°F], 3 Hr	Discoloration = Copper plate No. 3 or less (deep discoloration)	Discoloration = Copper plate No. 3 or less (deep discoloration)	JIS K 2513 ISO 2160
Density	15°C [59°F]	0.83 to 0.87 g/cm ³ [51.82 to 54.31 lb/ft ³]	0.80 to 0.87 g/cm ³ [49.94 to 54.31 lb/ft ³]	JIS K 2249 ISO 3675

Table 4-5 Fuel Properties Table (2/2)

Item		Recommended limit	Service limit	Remark
Coking	250°C [482°F], 24 Hr	Carbonization 75% or less	Carbonization 80% or less	Fed791B (U.S.A.)
	230°C [446°F], 24 Hr	Carbonization 55% or less	-	
	180°C [356°F], 48 Hr	Tar-free	-	
Aromatics	HPLC method	38 volume% or less (total of aromatic content)	38 volume% or less (total of aromatic content)	JIS K 2536 ISO 3837
Polycyclic aromatic content		8 volume% or less	8 volume% or less	
Asphaltene		0.1 mass% or less	0.1 mass% or less	-
Paticulate foreign substance	Foreign substances at engine fuel inlet	10 mg/L or less	10 mg/L or less	JIS B 9931 ISO 4405
Lubricity	HFRR wear test MWSD (Measured mean Wear Scar Diameter) At 60°C [140°F]	460 µm [0.02 in.] or less (calculated wear scar diameter at standard vapour pressure 1.4 kPa {0.01 kgf/cm ² } [0.20 psi])	-	ISO 12156-1
BDF: Biodiesel fuel (FAME: Fatty Acid Methyl Ester)		BDF quality shall meet JIS K 2390, or ASTM D6751 or EN14214. BDF blending of 7 volume% or less is approved *4		JIS K 2390 (FAME for blended fuel) ASTM D6751 EN 14214

*1: Cetane index (JIS K 2280) substitutes. When the fuel which satisfies the service limit of cetane number is not available with some inevitable reasons, the use of cetane booster is allowed. However, this is allowed only for the period before getting the fuel which satisfies the service limit after consulting with the fuel supplier and the manufacturer of cetane booster, and at the customer's own risk.

The additive rate of 0.5 % or less of cetane booster, and the lube oil analysis at every 125 hours are recommended.

High concentration of additive may cause metal elusion, rubber material infiltration, increased load in high-load operation, and acceleration of lube oil deterioration.

- Brand examples of cetane number improver
HITEC 4105K (Made by Afton Chemical)

*2: Only the emergency generator operated at an ambient temperature of 5°C [41°F] or more, a fuel of cetane number 40 to 45 and sulfur content 0.2% or less can be used, if the below requirements are satisfied:

- Install a water heater.
- Time from startup to load input is to be 40 seconds.
- Operating the engine at no load or low load (load factor 30% or less) for a prolonged period of time is avoided.

*3: If the sulfur content of using fuel is higher than 0.2 mass%, use the specified engine oil "[5 ENGINE OIL](#)" ([→ Page 110](#)).

*4: In case of using BDF, consult with the fuel supplier, and consider and take necessary treatment such as;

- Antioxidation at high temperature
- Prevention from fuel solidification at low temperature
- Prevention from growth of microbe
- Removal of moisture

For details, refer to 'Technical Information'

For Engine warranty coverage, refer to Limited Warranty conditions in this manual.

*5: Disregarding the value in could result in serious accident.

5 ENGINE OIL

This chapter describes the engine oil which is used for this engine.

Engine Oil

⚠ WARNING



Refer to the Engine Oil Properties table in this Operation & Maintenance Manual, and even if one item exceeds the limit, the engine oil must not be used.

* Otherwise, seizure of the sliding parts may occur, which could cause serious damage to the devices.



Use the genuine engine oil specified in this Operation & Maintenance Manual.

* Otherwise, seizure of bearings, breakage of a valve, sticking of a piston ring, seizure between a ring and a cylinder, premature wear of bearings and sliding parts may occur, which could shorten the service life of the engine.

Conduct analysis of the engine oil periodically and check to make sure that the engine oil does not show milky color.

* If the engine oil shows milky color, water may be mixed into the engine oil system due to coolant leak or a damaged cylinder liner O-ring. Use of the engine without any remedy could cause seizure of the crankshaft and lead to serious damage to the devices.

Keep the quantity and properties (viscosity) of the engine oil at the specified level.

* If the supply or kinematic viscosity of engine oil is too low, insufficient lubrication of the bearing could occur, which could cause seizure of the crankshaft.

* If kinematic viscosity of engine oil increases, fuel consumption will increase.

Use the genuine engine oil.

- JUKOIL Cojera CF15W-40
- JUKOIL Cojera CF30

When using the engine oil other than the genuine ones, use the engine oil which meets "[Engine Oil Quality Standards](#)" (→ [Page 199](#)).

Do not mix and use Engine oil of different types and/or manufacturers.

In addition, conduct the oil analysis earlier than the normal change interval and check the change interval.

Note

- **If you use the engine oil which does not meet "[Engine Oil Quality Standards](#)" (→ [Page 199](#)), for failures caused by the engine oil, the warranty will become invalid.**

Engine Oil Grade

Use a CF grade engine oil or a CH-4 grade oil which is certified by API service classification.

Note

- **When using a CF grade engine oil, use the engine oil which had been certified by API service classification CF grade by 2009 and meets "[Engine Oil Quality Standards](#)" (→ [Page 199](#)).**
- **When using a CH-4 grade oil, the sulfur content of fuel must be 0.2 mass% or less.**

Engine Oil Viscosity

Use the engine oil which viscosity is suitable to the ambient temperature.

Excessively high oil viscosity causes power loss and an abnormal rise in oil temperature.

Conversely, excessively low oil viscosity accelerates wear due to inadequate lubrication, and also causes a decrease in engine output by combustion gas blowing through.

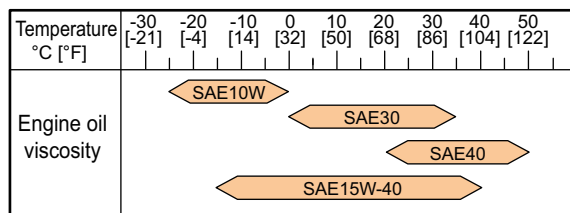

Fig. 5-1 Ambient Temperature and Engine Oil Viscosity

Handling Engine Oil

⚠ WARNING



Keep away from fire, when working with flammable substances such as engine oil.

* They may cause a fire.

Do not operate the engine with fuel or water mixed in the engine oil.

* Otherwise, viscosity of engine oil could decrease, which could cause seizure of the bearings or other serious accidents.

Do not store engine oil in a poorly ventilated place.

* Otherwise, vaporized engine oil may build up, which could cause an explosion or a fire on exposure to a flame.

⚠ WARNING



Wipe off spilled flammable substances such as engine oil thoroughly with a waste cloth.

* They may cause a fire.

When discarding a waste cloth used to wipe off combustible material, put it into a lidded can and obey the Waste Management and Public Cleansing Act to handle it as a special industrial waste.

* It may cause a fire.

* It could lead to environmental pollution.

* If you violate rules, you may be subject to penalties.

When handling engine oil, obey the manufacturer's SDS.

* If engine oil gets in your eyes, it will cause pain and lead to sight loss at the worst.

Do not breathe in vaporized engine oil.

* Otherwise, it could be hazardous to your health.

When storing engine oil in the container, be sure to close the cap.

* Otherwise, vaporized engine oil may build up, which could cause an explosion or a fire on exposure to a flame.

- When handling a large amount of engine oil more than the legally specified quantities, be sure to have the work performed in a service station operated under the provision of the law.
- When taking oil from an oil can or the like, use an oil pump.
- Tighten the oil can cap securely, and store the oil can in a well-ventilated place and out of direct sunlight.
- Be sure to obtain the SDS of the engine oil to be used and follow the instructions in the SDS.

6 COOLANT

This chapter describes coolant to be used. In this manual, the word "coolant" represents a mixture of water and LLC.

Water to Be Used

⚠ WARNING



When you add water to coolant, use only the water that meets the water quality standard specified in this Operation & Maintenance Manual.

* Otherwise, premature corrosion or overheating in the engine parts may occur.

Use soft water (tap water) which meets the requirements specified in the table below.

Table 6-1 Water Quality Standard

	pH (25°C [77°F])	Electrical conductivity (mS/m)	Total hard- ness	M alkalinity	Chlorine ion	Sulphate ion	Total iron	Silica	Residue by evaporation
Recom- mend value	6.5 to 8.0	≤ 25	≤ 95	≤ 70	≤ 100	≤ 50	≤ 1.0	-	≤ 250
Limit value	6.5 to 8.5	≤ 40	≤ 100	≤ 150	≤ 100	≤ 100	≤ 1.0	≤ 50	≤ 400
Main harm	Corrosion Scale formation	Corrosion Scale formation	Scale formation	Scale formation	Corrosion	Corrosion	Scale formation	Scale formation	Scale formation

- **In addition to the items specified above, turbidity must be below 15 mg/liter.**
- **Basically, the water quality should be within the range of the recommended values, however, up to the limit value is acceptable.**

LLC to Be Used

DANGER



Use the genuine LLC specified in this Operation & Maintenance Manual.

* Otherwise, the devices could be damaged.

Use the genuine LLC.

- GLASSY long life coolant (ethylene glycol type)
- PG GLASSY long life coolant (propylene glycol type)

Note

- **For GLASSY Long Life Coolant, 30% diluted solution (18L [4.76 US gal], 200L [52.84 US gal]) is available.**

When using an LLC other than the genuine ones, use an LLC which meets "[Requirements for LLC](#)" ([→ Page 203](#)) and "[LLC Quality Standard](#)" ([→ Page 203](#)). Do not mix and use Engine oil of different types and/or manufacturers.

Note

- **If you use an LLC which does not meet "[Requirements for LLC](#)" ([→ Page 203](#)) and "[LLC Quality Standard](#)" ([→ Page 203](#)), for failure due to the LLC, warranty will become invalid.**
- **The quality and performance of commercially available LLCs and their component variations are the responsibility of LLC suppliers.**
- **Before purchasing a commercial LLC, be sure to discuss the suitability of LLC with the LLC supplier.**
- **Be sure to use an all-season (non-amine) type long life coolant that prevent freezing of cooling water. Do not use antifreeze alone instead of LLC. For details, refer to "[Examples of Abnormalities Caused by LLC \(Amine Type\)](#)" ([→ Page 207](#)).**

Coolant (LLC) - Handling

WARNING



Keep away from fire, when working with flammable substances such as coolant (LLC).

* They may cause a fire.



Wipe off spilled flammable substances such as coolant (LLC) thoroughly with a waste cloth.

* They may cause a fire.

When discarding a waste cloth used to wipe off combustible material, put it into a lidded can and obey the Waste Management and Public Cleansing Act to handle it as a special industrial waste.

* It may cause a fire.

* It could lead to environmental pollution.

* If you violate rules, you may be subject to penalties.

Use care not to let oil mixed with coolant.

* Otherwise, cooling failure could occur, which could cause overheating.

When handling coolant (LLC), always wear suitable personal protective equipment such as rubber gloves and protective eyeglasses.

* If LLC comes into contact with your eyes, it will result in sight loss at the worst.

* If LLC comes into contact with your skin while the engine is hot, you could get burned by heat.

Maintenance of LLC

LLC Concentration in Coolant - Check

Be sure to drain a small amount of coolant and check the LLC concentration every 4000 service hours for the continuous use engine, and every six months for the emergency use engine.

["LLC Concentration in Coolant - Measure" \(→ Page 115\)](#)

Replacement Period

⚠ DANGER



Do not use LLC after the recommended storage expiration date.

* Otherwise, the devices could be damaged.

Change the coolant every 8000 hours or 2 years, whichever comes first for the continuous use engine. For the emergency use engine, be sure to change the coolant once every 2 years.

Coolant - Mix

- Check the LLC concentration in coolant ["LLC Concentration \(Genuine LLC\)" \(→ Page 114\)](#).**
- Check the quantity of coolant to be refilled.**
 - When replacing, check the specified quantity of coolant. ["SPECIFICATIONS - CHECK" \(→ Page 12\)](#)
 - When refilling, check with the scale on the tank.

Note

- Refill coolant into the engine after mixing. Do not refill only water or LLC.**
- If coolant is refilled without proper stirring, partially contrasting density of the LLC concentration may occur, which could interfere with the sufficient anticorrosion and cooling properties.**

- Prepare a vessel for mixing and pour in water ["Water to Be Used" \(→ Page 112\)](#).**
- In accordance with the LLC concentration checked in Step 1, add LLC ["LLC to Be Used" \(→ Page 113\)](#).**
- Check the LLC concentration in mixed coolant. ["LLC Concentration in Coolant - Measure" \(→ Page 115\)](#)**
- Refill the mixed coolant into the engine. ["Coolant - Change" \(→ Page 156\)](#)**

LLC Concentration (Genuine LLC)

⚠ DANGER



Keep LLC to be the specified concentration.

- * If LLC concentration is low, it could cause corrosion of the radiator or heat exchanger.
- * If LLC concentration is high, it may cause damage to the devices or overheat due to the seized engine parts.

The concentration of LLC required for anti-freeze is determined by the ambient minimum temperature. Be sure to follow the range shown in the following table.

Table 6-2 LLC Concentration

Type	External appearance	Ambient temperature			
		down to -10°C [14°F]	down to -20°C [-4°F]	down to -30°C [-22°F]	down to -45°C [-49°F]
GLASSY	Green	30%	40%	50%	60%
PG GLASSY	Red	40%	55%	70%	90%

- The upper limit of the LLC concentration is 60% for GLASSY and 90% for PG GLASSY. If the concentration is higher than above, the antifreeze effect will be lowered, or the coolant temperature will be increased due to the lowered specific heat.
- The coolant temperature increases by approximately 1.5°C [2.7°F] for GLASSY at 60% concentration and by approximately 3°C [5.4°F] for PG GLASSY at 90% concentration. Check heat exchanger capacity of the cooling system to avoid overheating.

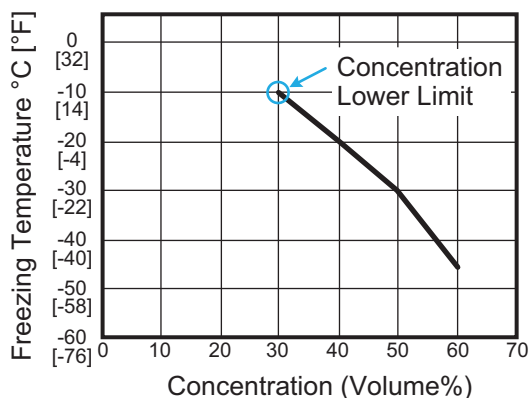

Fig. 6-1 Freezing Temperature of GLASSY

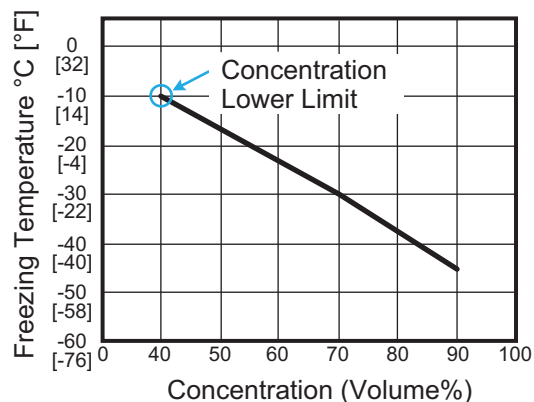

Fig. 6-2 Freezing Temperature of PG GLASSY

Note

- **When using the other LLC follow the instruction manual of LLC to be used.**

LLC Concentration in Coolant - Measure

To measure the LLC concentration, the following tool is required.

- Tool: Coolant tester

Note

- **When using other tools, follow the instruction manual attached to the tool to be used.**

Tool - Adjust

- 1 Place 1 or 2 drops of distilled or tap water on the prism.**

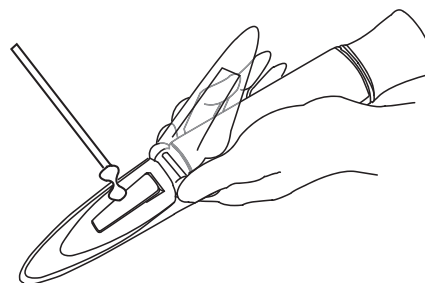

Fig. 6-3 Tool - Adjust 1

- 2 Close the daylight plate slowly.**

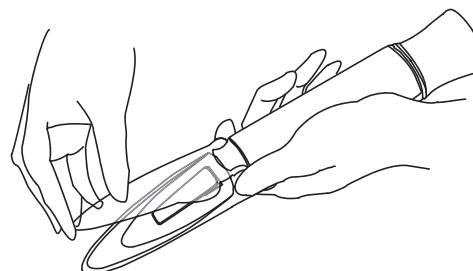

Fig. 6-4 Tool - Adjust 2

- 3 **Spread a drop of water over the surface of the prism taking care that air bubbles will not enter it.**

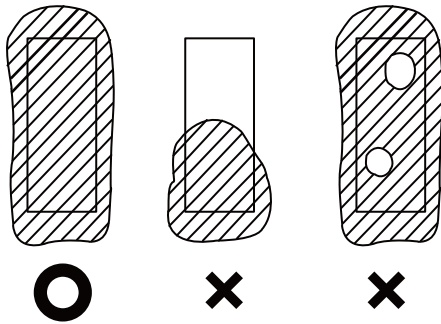

Fig. 6-5 Tool - Adjust 3

- 4 **Read the scale through the eyepiece.**

- Rotate the eyepiece to either side to focus.

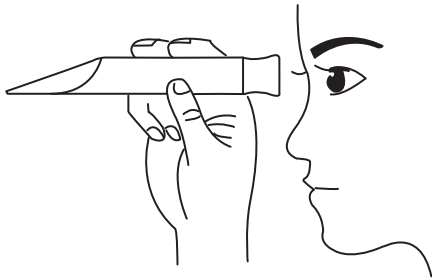

Fig. 6-6 Tool - Adjust 4

- 5 **Confirm the boundary line of blue color aligns with the 0% on the scale.**

- If it does not align, rotate the scale adjusting screw by using a scale adjusting tool and let it align.

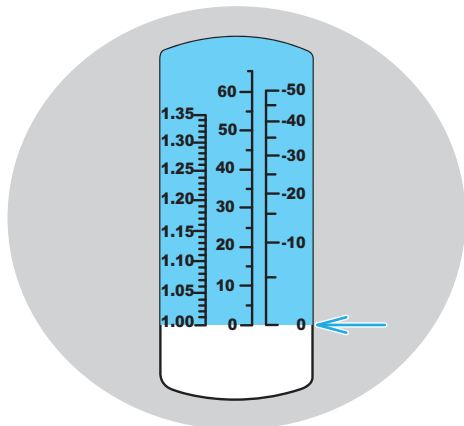

Fig. 6-7 Tool - Adjust 5

- 6 **Wipe the surface of the prism and daylight plate with water-soaked soft facial tissue.**

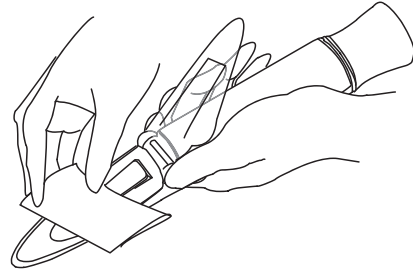

Fig. 6-8 Tool - Adjust 6

Measurement

Note

- Before measuring the LLC concentration, be sure to adjust tools "[Tool - Adjust](#)" ([→ Page 115](#)).

- 1 **Place a sample of 1 or 2 drops of coolant/water mixture on the prism.**

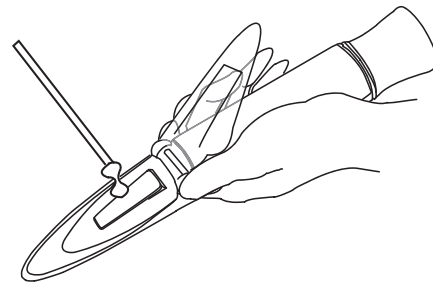

Fig. 6-9 LLC Concentration Measurement 1

- 2 **Close the daylight plate slowly.**

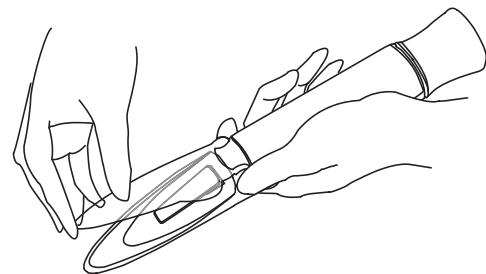

Fig. 6-10 LLC Concentration Measurement 2

- 3 Spread a drop of water over the surface of the prism taking care that air bubbles will not enter it.**

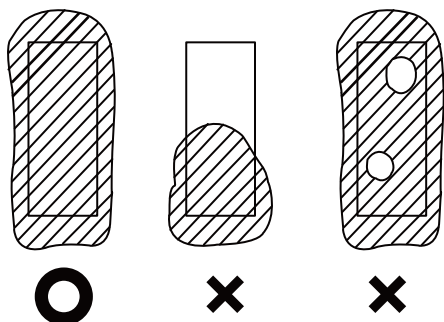

Fig. 6-11 LLC Concentration Measurement 3

- 4 Read the scale through the eyepiece.**

- Rotate the eyepiece to either side to focus.

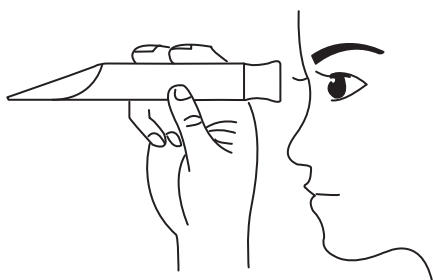

Fig. 6-12 LLC Concentration Measurement 4

- 5 Read the scale at the position where the blue boundary line comes across.**

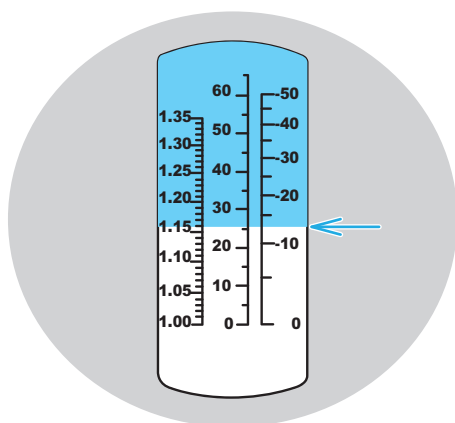

Fig. 6-13 LLC Concentration Measurement 5

- How to read the Scale
The scale of the coolant tester is for the ethylene glycol type. When measuring a propylene glycol type, convert the reading to judge by using the table below.

Table 6-3 Scale Conversion Table

Scale markings	0	5	10	15	20	25	30	35	40	45	50
Corresponding value	0	5	9	14	18	22	26	31	35	39	44

- 6 Wipe the surface of the prism and daylight plate with water-soaked soft facial tissue.**

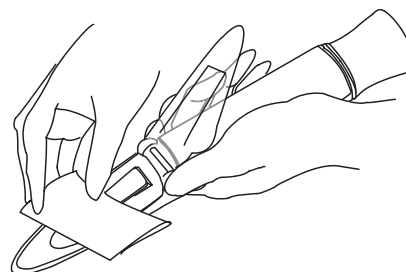

Fig. 6-14 LLC Concentration Measurement 6

7 SCHEDULED MAINTENANCE

This chapter describes the scheduled maintenance schedule in which details of the scheduled maintenance and its cycle are listed up.

⚠ WARNING



Do not take actions for items indicated as "Contact your MHIET dealer" in the measure column in the Scheduled Maintenance.

* Otherwise, serious accident, environmental pollution or damage to the devices may occur. Be sure to contact your MHIET dealer.



Be sure to perform the pre-operation check and scheduled maintenance as instructed in this Operation & Maintenance Manual.

* Failure to perform the pre-operation check and scheduled maintenance may cause various engine problems and breakage to parts, which may result in serious accidents.

How to Use the Scheduled Maintenance

Scheduled maintenance not only extends the service life of the engine but also serves to ensure the safe operation.

Be sure to conduct the inspection and maintenance in accordance with the "SCHEDULED MAINTENANCE".

However, if you notice abnormalities as shown below, be sure to conduct the inspection and maintenance work regardless of recommended service intervals in the "SCHEDULED MAINTENANCE".

- Noise
- Significant black or white exhaust smoke
- Abnormal exhaust gas temperature
- Abnormal vibration
- Fuel leaks
- Engine oil leaks
- Exhaust gas leaks

Note

- **Appropriate service intervals vary with usage and operating conditions as well as conditions of fuel, oil, and coolant. Check the results and shorten the interval as necessary.**

Be sure to check the items which are included in the applicable interval and shorter intervals. For example, in the 2000 hour maintenance, also check those items listed in every 50, 250, 500, and 1000 hours.

Category of Scheduled Maintenance Chart

- Appropriate service intervals vary depending on the intended purpose or use of the engine. Perform all daily check items in accordance with the following 2 categories.
- Regardless of the intended use, its operation is regulated in terms of the annual operating time. Refer to the "[Rating Definition](#)" (→ [Page 120](#)) to check the interval of overhauls.

■ Scheduled Maintenance for Continuous Use Engine

For the continuous use engine, perform the scheduled maintenance in accordance with the "Scheduled Maintenance for Continuous Use Engines".

■ Scheduled Maintenance for Emergency Use Engine

For the emergency use engine, perform the scheduled maintenance in accordance with the "Scheduled Maintenance for Emergency Use Engines".

In addition, carry out maintenance operation regularly. "[Maintenance Operation](#)" (→ [Page 103](#))

Rating Definition

Table 7-1 MHIET Generator Use Diesel Engine Rating Definition (1/2)

Symbol		E			P			
Name of rating (ISO 8528-1:2018 description)		Critical Power Operation (no ISO equivalent)	Emergency standby power (ESP)		Prime			
					Limited-time running power (LPT)	Prime power (PRP)		
Overload operation (Rack set)		n.a.(E) *5	n.a (E)		10% (E)			
Definition		Stand-by usage with the maximum 300hr continuous operation. Typically example: For Data center.	Rated power of an emergen- cy generator as Stand-by that supplies power in case of a failure of main power source or commercial power.		Regular power source of which the operating hour is limited to the short period as specified in the required con- ditions for warranty in this document. This rating shall be used for applica- tions that require overload operation with Stand-by.		For generators with variable load and unlimited operating hour.	
Required conditions for warranty *1	Load/ operating hour *2	Ave. load factor/ 24Hr	-		Maximum 80% (100% in emergency)		Overload operation (≤110%) is limited to a max. of 1Hr per 12Hr.	Maximum 80% Overload operation (≤110%) is limited to a max. of 1Hr per 12Hr. Over 90% load operation is limited to a max. of 3Hr per 24Hr.
		Ave. load factor /yr	Maximum 100%	Maximum 70% *7	Maximum 60%	Maximum 70% *7	Maximum 70% *7	Maximum 60%
		Operating Hr/yr *4	Unlimited	Maximum 500Hr *7		Maximum 500Hr *7	Unlimited *7	
	Overhaul interval after delivery <Maximum> *3	Top	4yr (Only the case ex- ceed 500Hr by 4yr)	1000Hr or 4yr whichever comes earlier	4yr	4yr	3500Hr or 4yr whichever comes earlier	4000Hr or 4yr whichever comes earlier
		Major	600Hr or 8yr whichever comes earlier	2000Hr or 8yr whichever comes earlier	3000Hr or 8yr whichever comes earlier	1000Hr or 8yr whichever comes earlier	7000Hr or 8yr whichever comes earlier	8000Hr or 8yr whichever comes earlier
Application		Emergency, stand-by			Seasonal peak cut	Daily peak cut, portable generator		

*1: This condition constitutes a part of required conditions for warranty that Mitsubishi Heavy Industries Engine & Turbocharger, Ltd. (hereinafter "MHIET") agrees with the other party under Diesel Engine Sales Contract with the party (hereinafter "Individual Contract"), however details of the warranty descriptions and the conditions shall be referred to the Individual Contract. Atmospheric condition as per ISO 15550:2002 (JIS B 8003:2005)

(Barometric pressure :100kPa, ambient temperature :298K, relative humidity :30%).

*2: Average load factor (per day or year) shall be calculated as per the formula in ISO 8528-1:2018 'average power output (Ppp)'.

*3: Refer to Operation Manual for more information regarding inspection and maintenance including items and descriptions.

*4: Warranty coverage shall be expired after Major Overhaul.

*5: For backup or emergency purpose engine, it is needed to have output margin of 5% or more for the customer demand output to avoid engine stall by output tolerance (ISO 15550) and frequency variation etc.

*6: The rating is consistent with the requirement of a Tier III and Tier IV under the Uptime Institute.

*7: Conditions are consistent with the requirements under ISO 8528-1:2018.

This document is subject to change without prior notification.

Table 7-2 MHIET Generator Use Diesel Engine Rating Definition (2/2)

Symbol		DCP *6	C	D		
Name of rating (ISO 8528-1:2018 description)		Data center power (DCP)	Continuous power (COP)			
Overload operation (Rack set)		10% (E)	n.a (C)		n.a. (D)	
Definition		For generator in Data center application (where reliable grid is available)	Rating that can continuously generate power without limitation for operating hour per year under the required conditions for warranty in this document.		In addition to the for symbol C above, this rating shall be used 90% or more average load factor or longer maintenance interval are required.	
Required conditions for warranty *1	Load/ operating hour *2	Ave. load factor/ 24Hr	100% load is allowed in case of grid failure. Overload operation ($\leq 110\%$) is limited to a max. of 1Hr per 12Hr.	Maximum 100%	Maximum 90%	Maximum 100%
		Ave. load factor /yr	Maximum 100% *7	Maximum 100% *7	Maximum 90%	Maximum 100% *7
		Operating Hr/yr *4	Unlimited *7	Unlimited *7	Unlimited	Unlimited *7
	Overhaul interval after delivery <Maximum> *3	Top	500Hr or 4yr whichever comes earlier	6000Hr or 4yr whichever comes earlier (Recommended:4000Hr)	8000Hr or 4yr whichever comes earlier (Recom- mended:6000Hr)	8000Hr or 4yr whichever comes earlier (Recom- mended:6000Hr)
		Major	1000Hr or 8yr whichever comes earlier	12000Hr or 8yr whichever comes earlier (Recommended:8000Hr)	16000Hr or 8yr whichever comes earlier (Recom- mended:12000Hr)	16000Hr or 8yr whichever comes earlier (Recom- mended:12000Hr)
Application		Data center	Base load, cogeneration system			

*1: This condition constitutes a part of required conditions for warranty that Mitsubishi Heavy Industries Engine & Turbocharger, Ltd. (hereinafter "MHIET") agrees with the other party under Diesel Engine Sales Contract with the party (hereinafter "Individual Contract"), however details of the warranty descriptions and the conditions shall be referred to the Individual Contract. Atmospheric condition as per ISO 15550:2002 (JIS B 8003:2005)

(Barometric pressure :100kPa, ambient temperature :298K, relative humidity :30%).

*2: Average load factor (per day or year) shall be calculated as per the formula in ISO 8528-1:2018 'average power output (Ppp)'.

*3: Refer to Operation Manual for more information regarding inspection and maintenance including items and descriptions.

*4: Warranty coverage shall be expired after Major Overhaul.

*5: For backup or emergency purpose engine, it is needed to have output margin of 5% or more for the customer demand output to avoid engine stall by output tolerance (ISO 15550) and frequency variation etc.

*6: The rating is consistent with the requirement of a Tier III and Tier IV under the Uptime Institute.

*7: Conditions are consistent with the requirements under ISO 8528-1:2018.

This document is subject to change without prior notification.

Scheduled Maintenance for EPA Compliant Generator Use Diesel Engine

Table 7-3 Maintenance Schedule (1/2)

Inspection and Maintenance Period	Service Items		Actions
Service Period			
Every week	Walk around check		Check
	Engine Oil Level		Check
	Coolant Level		Check
	Air Cooler		Check Water Leak
	Maintenance Operation (Operate the engine at no load for 5 to 10 minutes)		-
Every month	Ingress of Fuel and Water In Engine Oil		Check
	Fuel Control Link		Check
	Maintenance Operation (Operate the engine at 50% load or morer for 30 minutes or longer)		-
Every 6 months	LLC Concentration in Coolant		Check
Every year	Engine Body	Belt and Belt Tension	Check and Adjust (Replace Parts as needed)
		Bolts and Nuts on Engine	Check and Retighten
		Damper	Check
		Valve Clearance (Check the valve mechanism parts at the same time)	Check and Adjust
	Fuel System	Fuel Injection Nozzle Spray Condition and Injection Pressure	Inspect and Adjust
		Fuel Injection Timing	Check and Adjust
		Fuel Pipe	Check
	Cooling System	Water Pump	Check
		Coolant Properties	Inspect (Change Coolant Based on Analysis Results)
	Electrical System	Starter	Check
		Alternator	Check
	Protection System		Check
	Auxiliary Devices		Check

Table 7-4 Maintenance Schedule (2/2)

Inspection and Maintenance Period	Service Items	Actions
Service Period		
Every 2 years	Engine Oil, Oil Filter, and Bypass Oil Filter	Replace
	Fuel Filter	Replace
	Gauze Filter	Clean
	Fuel Control Link Ball Joint	Check (Replace Parts as needed)
	Coolant	Change
	Thermostat	Check
	Turbocharger	Check
Every 4 years	Engine	Top Overhaul
	Oil Cooler	Check
	Oil Pump	Check
	Fuel Injection Pump	Inspect and Test (Replace Parts as needed)
	Governor	Inspect and Test (Replace Parts as needed)
	Rubber Hose	Replace
	Various Instruments (gage, meter)	Repair or Replace
Every 8 years	Engine	Major Overhaul
	Damper	Replace
	Oil Pump	Repair or Replace
	Fuel Injection Nozzle Tip, Spacer, and Nozzle Spring	Replace
	Rubber Parts and O-rings	Replace
	Water Pump Unit Seal and Oil Seal	Replace
	Turbocharger	Disassemble and Inspect
	Air Cooler	Disassemble and Clean
	Stop Solenoid	Check or Replace
	Other Consumable Parts	Replace

8 INSPECTION AND MAINTENANCE

This chapter describes the inspection and maintenance procedure.

Inspection and Maintenance - General Information

Be sure to conduct the inspection and maintenance according to the "[7 SCHEDULED MAINTENANCE](#)" ([→ Page 118](#)).

Inspection and Maintenance - Prepare

- Inspection and Maintenance - Prepare (with Engine Switched ON)
- Inspection and Maintenance - Prepare (with Engine Switched OFF)

Engine Body - Check

- Belt - Check
- Belt Tension (Alternator) - Adjust
- Damper - Check
- Damper Temperature - Check

Fuel System - Check

- Fuel Tank - Check and Service
- Fuel System - Bleed Air
- Water Separator - Check and Service
- Gauze Filter - Clean
- Fuel Filter - Replace
- Fuel Control Link - Check
- Fuel Pipe - Check

Engine Oil System - Check

- Engine Oil - Change
- Oil Filter - Replace
- Bypass Oil Filter - Replace
- Governor Oil Filter - Replace (Hydraulic governor spec)
- Oil Pipe - Check

Cooling System - Check

- Coolant - Change
- Cooling System - Bleed Air
- Radiator Fins - Check and Clean (Radiator Spec)
- Resin Fan Inspection (Specifications with Resin Fan)

Intake and Exhaust Systems - Check

- Turbocharger - Check
- Exhaust Muffler - Drain Water
- Pre-cleaner - Check and Service
- Air Cleaner - Check and Service

Electrical System - Check

- Battery - Check
- Starter - Check (Self Starter Motor Starting)
- Alternator - Check

Air Direct Admission Starting, Air Motor Starting - Check

- Starter Air Strainer - Drain Water and Clean
- Starting Air Tank - Check and Service (Air Direct Admission Starting, Air Motor Starting)
- Starting Air Motor - Check (Air Motor Starting)

Precautions for General Inspection and Maintenance

DANGER



Before starting the engine, pull out the manual turning gear shaft.

- * Starting the engine while the turning gear is engaged with the ring gear could result in serious personal injury or destruction of the engine.

Before inspecting and maintaining the engine, read this Operation & Maintenance Manual thoroughly to understand the construction and the required work to service the corresponding part.

- * In case of conducting the work without studying enough, an accident or damage due to wrong installation, or deterioration in the exhaust gas properties may occur.

WARNING



Do not make any modifications to the engine without our previous written agreement.

- * Otherwise, damage to the devices or significant environmental pollution may occur.
- * In such a case, the whole warranty will become invalid.

Do not work while standing on the engine.

- * Otherwise, you may slip and fall by accident, and get injured.
- * In addition, the devices or pipes may be damaged.

Do not disconnect the fuel or engine oil piping while the engine is operating or at high temperature.

- * Otherwise, fuel could come in contact with the engine, which could cause a fire.

Do not disconnect the pipes immediately after the engine is stopped.

- * Otherwise, you could get burned by hot engine oil or coolant splashing out.

WARNING



Do not touch any part of the engine (other than the manual stop lever) during or immediately after operation and immediately after stopping.

- * If you touch, you could get burned by heat.
- * Before starting the inspection and maintenance work, make sure that the engine is cooled down.



Only the genuine parts are recommended to use.

- * Using non-genuine parts could cause deterioration in the exhaust gas properties and damage to the devices.
- * Failures or damages caused by using non-genuine parts will be outside the scope of the warranty.

While washing the engine, pay attention that water or foreign particles will not enter the engine.

- * Otherwise, the devices could be damaged.

After washing the engine, blow off water around the terminals by using compressed air.

- * Otherwise, it may cause damage to the devices due to short circuit.

Before maintaining electrical components, place the battery switch to the OFF position or disconnect the battery negative (-) terminal.

- * Electric shock could result when electricity flows through the circuit.

Wipe off spilled flammable substances such as fuel, engine oil, coolant (LLC), grease, rust preventive oil and anti-corrosive agent.

- * They may cause a fire.

When discarding a waste cloth used to wipe off combustible material, put it into a lidded can and obey the Waste Management and Public Cleansing Act to handle it as a special industrial waste.

- * It may cause a fire.
- * It could lead to environmental pollution.
- * If you violate rules, you may be subject to penalties.

⚠ WARNING

Make sure that dripped oil, parts, tools or other things are not left on the floor around the engine. Always maintain cleanliness and tidiness.

- * Otherwise, a tumbling accident may occur.
- * Wear proper personal protective equipment for the work.

Watch your step during inspection and maintenance work.

- * Otherwise, a tumbling accident or a falling accident may occur while working on the floor panel or other high positions.
- * The floor could be extremely slippery due to spilt oil. Thoroughly wipe off oil on the floor and the sole of your shoes.
- * Install a stable scaffold as required.

Cover the disconnected pipes or joints and their openings properly so that dusts or other foreign objects will not enter into them.

- * Otherwise, the devices may be damaged.

The engine must be inspected and maintained only by qualified persons who have received a required training or on-site instructions, or done so under the mentorship of a person who have completed our training course.

- * Otherwise, serious personal injury or damage to the devices may occur.

When working on the upper part of the engine and other hard-to-reach places, use a stable work platform.

- * Do not stand on an old stool or parts box. Otherwise, it may result in personal injury. In addition, do not put any unnecessary objects on a work platform.

⚠ CAUTION

While inspecting and maintaining, do not put your hand in a gap between the connecting rod, crankshaft, timing gear or others and the crankcase.

- * Otherwise, you may be stuck and injured.

While operating the engine, stay away from the moving parts.

- * Otherwise, you may cut your hand by the rotating parts, or be caught in them and injured.

Inspection and Maintenance - Prepare**⚠ WARNING**

Make sure that the tools to be used are not damaged.

- * Using a damaged tool or a wrong-size tool may cause personal injury or damage to the devices.

Check and calibrate measurement equipment periodically.

- * Using uncalibrated measurement equipment may cause damage to the devices or performance degradation of them.

Before inspection and maintenance work, be sure to prepare as follows according to the content of inspection and maintenance:

Note

- **Devices and equipment outside the scope of our supply are included in the facility. For the details, refer to such a document as the specification sheet prepared by the generator supplier.**
- **For the devices and equipment outside the scope of our supply, refer the corresponding manual of the generator and the supplier's operation manual.**

Inspection and Maintenance - Prepare (with Engine Switched ON)

- 1 **Post a sign "Do Not Operate", for example, on the operation panel of the generator and let the other operators not to operate. ["Starting and Stopping Devices Installed during Manufacturing the Generator"](#) (→ [Page 87](#))**

Inspection and Maintenance - Prepare (with Engine Switched OFF)

WARNING



Be sure to lockout/tagout before starting inspection and maintenance work.

* Unexpected startup of the engine could cause serious personal injury or damage to the devices.

Be sure to establish zero energy state before starting inspection and maintenance work.

* Unexpected activation of the devices could cause serious personal injury or damage to the devices.

- 1 **Operate the stop switch of the generator ["Starting and Stopping Devices Installed during Manufacturing the Generator"](#) (→ [Page 87](#)) to turn off the engine.**
- 2 **Make sure with the thermometer (thermo gun, etc.) that the surface of the engine is cooled down so that you can touch.**
- 3 **Conduct lockout/tagout. ["Lockout/Tagout"](#) (→ [Page 62](#))**

Engine Body - Check

Note

- **Devices and equipment outside the scope of our supply are included in the facility. For the details, refer to such a document as the specification sheet prepared by the generator supplier.**
- **For the devices and equipment outside the scope of our supply, refer the corresponding manual of the generator and the supplier's operation manual.**

Belt - Check

WARNING



Stay away from rotating parts during operation.

* Otherwise you may get caught in the rotating parts and seriously injured.

CAUTION



Keep the belt for the crankshaft pulley or alternator free from oil and grease.

* Otherwise, a slip could occur, which will shorten the service life of the belt.



Check each belt status (tension, damage and the like) of the crankshaft pulley or alternator.

* If the belt has been stretched, the battery cannot be charged and DC power supply will be lost.

Check each belt for the crankshaft pulley or alternator in the engine.

1 Check the belt visually.

- Check for peeling or breaks.
→If any abnormality is found, replace the belt with a new one.

2 Check the belt tension.

→If the belt tension is out of the standard value, adjust the belt tension. ["Table 8-3 Ribbed Belt Tensile Force"](#) (→ [Page 131](#))

Note

- **The new belt has an initial stretch. Operate the engine for about 1 hour and adjust the belt tension again.**

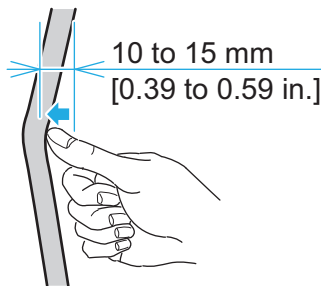

Fig. 8-1 Belt Tension - Adjust (V-belt)

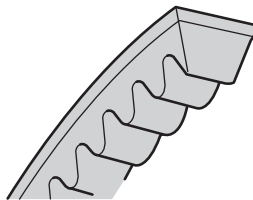

Fig. 8-2 Shape of V-belt

Table 8-1 Type of Belt (V-belt)

Type of Belt	Standard value
V-belt	When the center of the belt span is pressed with a force of approx. 98 N {9.99 kgf} [22.03 lbf] to 147N {14.99 kgf} [33.05 lbf], the deflection of the belt must be 10 to 15 mm [0.39 to 0.59 in.].

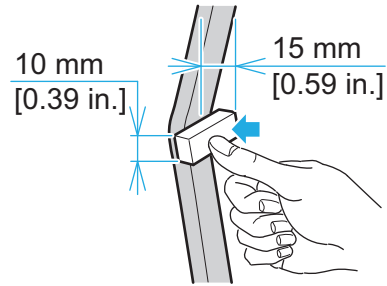

Fig. 8-3 Belt Tension - Adjust (Ribbed Belt)

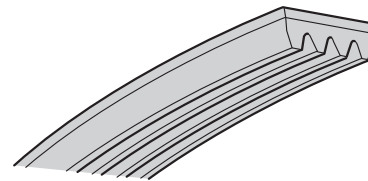

Fig. 8-4 Shape of Ribbed Belt

- Tool: Gauge (10 mm [0.39 in.] wide)

Table 8-2 Type of Belt (Ribbed Belt)

Type of Belt	Standard value
Ribbed Belt	When the midpoint of the straight part of the belt is pressed with a force of "Table 8-3 Ribbed Belt Tensile Force" (→ Page 131) by using a 10 mm [0.39 in.] wide gauge, the deflection is 15 mm [0.59 in.].

Belt Tension (Alternator) - Adjust

⚠ WARNING



Stay away from rotating parts during operation.

* Otherwise you may get caught in the rotating parts and seriously injured.



Adjust the belt tension properly in accordance with the procedures recommended by MHIET.

* Otherwise, the service life of the alternator, bearing or belt could be shortened.

* After you replaced the belt with a new one, check the tension again after the initial stretch of the belt is settled.

⚠ CAUTION



Keep the belt for the crankshaft pulley or alternator free from oil and grease.

* Otherwise, a slip could occur, which will shorten the service life of the belt.

Adjust the alternator belt tension.

Note

- For the location of the alternator, refer to "**2 ENGINE - OUTLINE**" (→ Page 76).

1 Remove the belt cover of the alternator.

- Tool: Wrench

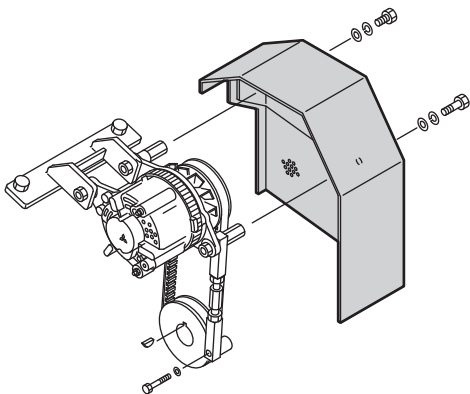

Fig. 8-5 Belt Cover - Remove

2 Loosen all retaining bolts (1) of the alternator and the adjusting rod.

- Tool: Wrench

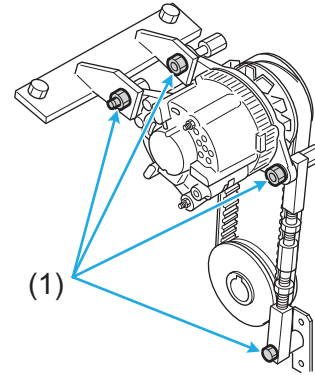

Fig. 8-6 Belt Tension - Adjust (Retaining Bolt)

3 Loosen the lock nut of adjusting rod.

- The upper lock nut (2) has a right-hand thread.
- The lower lock nut (3) has a left-hand thread.
- Tool: Wrench

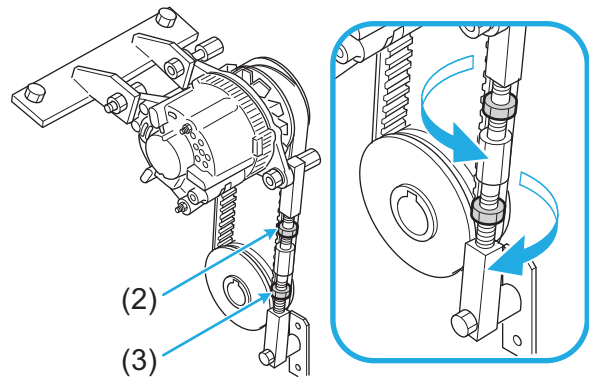

Fig. 8-7 Belt Tension - Adjust (Lock Nut)

4 Turn the turn buckle (4) of the adjusting bolt to adjust the belt tension.

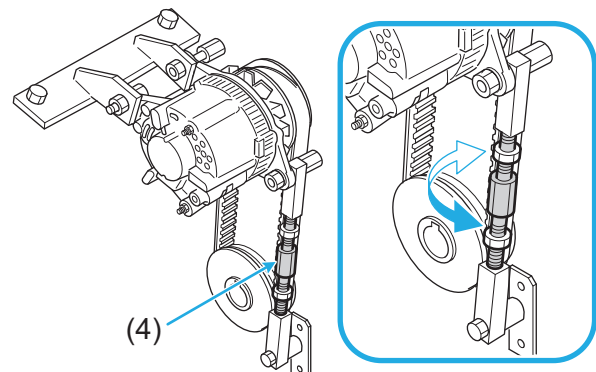

Fig. 8-8 Belt Tension - Adjust (Turn Buckle)

5 After adjusting deflection, tighten the lock nut of the adjusting rod.

- The upper lock nut (2) has a right-hand thread.
- The lower lock nut (3) has a left-hand thread.
- Tool: Wrench

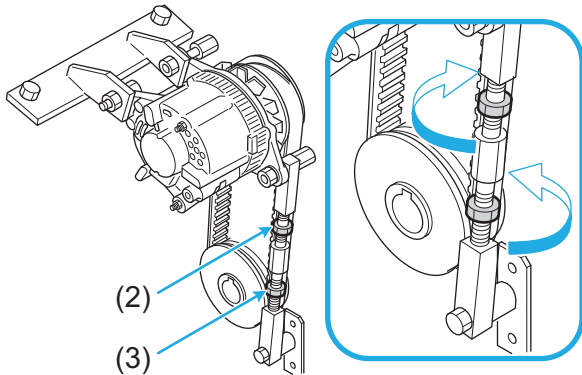

Fig. 8-9 Belt Tension - Adjust (Lock Nut)

6 Tighten the retaining bolts (1) of the alternator and the adjusting rod which were loosened in Step 2.

- Tool: Wrench

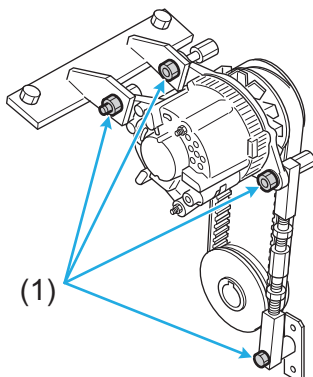

Fig. 8-10 Belt Tension - Adjust (Retaining Bolt)

7 Install the belt cover of the alternator which was removed in Step 1.

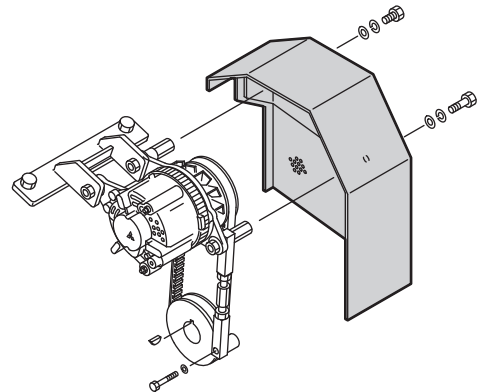

Fig. 8-11 Belt Cover - Install

8 Install the front cover.

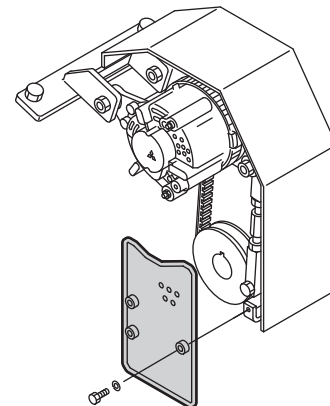

Fig. 8-12 Front cover - Install

Table 8-3 Ribbed Belt Tensile Force

Measuring item	Number of ribs	Belt straight distance (mm)				
		300 or less	more than 300 and 400 or less	more than 400 and 500 or less	more than 500 and 600 or less	more than 600
When a new belt is installed	3	74 N {7.55 kgf} [16.64 lbf]	49 N {5.00 kgf} [11.02 lbf]	37 N {3.77 kgf} [8.32 lbf]	29 N {2.96 kgf} [6.52 lbf]	25 N {2.55 kgf} [5.62 lbf]
	4	88 N {8.97 kgf} [19.78 lbf]	59 N {6.02 kgf} [13.26 lbf]	44 N {4.49 kgf} [9.89 lbf]	35 N {3.57 kgf} [7.87 lbf]	29 N {2.96 kgf} [6.52 lbf]
	5	103 N {10.50 kgf} [23.16 lbf]	69 N {7.04 kgf} [15.51 lbf]	51 N {5.20 kgf} [11.47 lbf]	41 N {4.18 kgf} [9.22 lbf]	34 N {3.47 kgf} [7.64 lbf]
	6	118 N {12.03 kgf} [26.53 lbf]	79 N {8.06 kgf} [17.76 lbf]	59 N {6.02 kgf} [13.26 lbf]	47 N {4.79 kgf} [10.57 lbf]	39 N {3.98 kgf} [8.77 lbf]
	7	132 N {13.46 kgf} [29.67 lbf]	88 N {8.97 kgf} [19.78 lbf]	66 N {6.73 kgf} [14.84 lbf]	53 N {5.40 kgf} [11.91 lbf]	44 N {4.49 kgf} [9.89 lbf]
	8	147 N {14.99 kgf} [33.05 lbf]	98 N {9.99 kgf} [22.03 lbf]	74 N {7.55 kgf} [16.64 lbf]	59 N {6.02 kgf} [13.26 lbf]	49 N {5.00 kgf} [11.02 lbf]
	9	162 N {16.52 kgf} [36.42 lbf]	108 N {11.01 kgf} [24.28 lbf]	81 N {8.26 kgf} [18.21 lbf]	65 N {6.63 kgf} [14.61 lbf]	54 N {5.51 kgf} [12.14 lbf]
	10	176 N {17.95 kgf} [39.57 lbf]	118 N {12.03 kgf} [26.53 lbf]	88 N {8.97 kgf} [19.78 lbf]	71 N {7.24 kgf} [15.96 lbf]	59 N {6.02 kgf} [13.26 lbf]
	11	191 N {19.48 kgf} [42.94 lbf]	127 N {12.95 kgf} [28.55 lbf]	96 N {9.79 kgf} [21.58 lbf]	76 N {7.75 kgf} [17.09 lbf]	64 N {6.53 kgf} [14.39 lbf]
	12	206 N {21.01 kgf} [46.31 lbf]	137 N {13.97 kgf} [30.80 lbf]	103 N {10.50 kgf} [23.16 lbf]	82 N {8.36 kgf} [18.43 lbf]	69 N {7.04 kgf} [15.51 lbf]
When retightened	3	51 N {5.20 kgf} [11.47 lbf]	34 N {3.47 kgf} [7.64 lbf]	26 N {2.65 kgf} [5.85 lbf]	21 N {2.14 kgf} [4.72 lbf]	17 N {1.73 kgf} [3.82 lbf]
	4	62 N {6.32 kgf} [13.94 lbf]	41 N {4.18 kgf} [9.22 lbf]	31 N {3.16 kgf} [6.97 lbf]	25 N {2.55 kgf} [5.62 lbf]	21 N {2.14 kgf} [4.72 lbf]
	5	72 N {7.34 kgf} [16.19 lbf]	48 N {4.89 kgf} [10.79 lbf]	36 N {3.67 kgf} [8.09 lbf]	29 N {2.96 kgf} [6.52 lbf]	24 N {2.45 kgf} [5.40 lbf]
	6	82 N {8.36 kgf} [18.43 lbf]	55 N {5.61 kgf} [12.36 lbf]	41 N {4.18 kgf} [9.22 lbf]	33 N {3.37 kgf} [7.42 lbf]	27 N {2.75 kgf} [6.07 lbf]
	7	93 N {9.48 kgf} [20.91 lbf]	62 N {6.32 kgf} [13.94 lbf]	46 N {4.69 kgf} [10.34 lbf]	37 N {3.77 kgf} [8.32 lbf]	31 N {3.16 kgf} [6.97 lbf]
	8	103 N {10.50 kgf} [23.16 lbf]	69 N {7.04 kgf} [15.51 lbf]	51 N {5.20 kgf} [11.47 lbf]	41 N {4.18 kgf} [9.22 lbf]	34 N {3.47 kgf} [7.64 lbf]
	9	113 N {11.52 kgf} [25.40 lbf]	75 N {7.65 kgf} [16.86 lbf]	57 N {5.81 kgf} [12.81 lbf]	45 N {4.59 kgf} [10.12 lbf]	38 N {3.87 kgf} [8.54 lbf]
	10	123 N {12.54 kgf} [27.65 lbf]	82 N {8.36 kgf} [18.43 lbf]	62 N {6.32 kgf} [13.94 lbf]	49 N {5.00 kgf} [11.02 lbf]	41 N {4.18 kgf} [9.22 lbf]
	11	134 N {13.66 kgf} [30.12 lbf]	89 N {9.08 kgf} [20.01 lbf]	67 N {6.83 kgf} [15.06 lbf]	54 N {5.51 kgf} [12.14 lbf]	45 N {4.59 kgf} [10.12 lbf]
	12	144 N {14.68 kgf} [32.37 lbf]	96 N {9.79 kgf} [21.58 lbf]	72 N {7.34 kgf} [16.19 lbf]	58 N {5.91 kgf} [13.04 lbf]	48 N {4.89 kgf} [10.79 lbf]

Note

- The pressing force when the midpoint of belt straight line is pressed by using the gauge with 10 mm [0.39 in.] wide and the belt is deflected by 15 mm [0.59 in.].

Damper - Check

⚠ WARNING



Install a protective cover which can dissipate heat.

* Otherwise, the damper could be enclosed and degenerated due to poor heat dissipation and ventilation, and which may cause breakage of the crankshaft.

Note

- For the location of the dampers, refer to **"2 ENGINE - OUTLINE"** (→ [Page 76](#)).

1 Check the external appearance of the damper for the items below:

- Oil leak from the cauking
- Flaw
- Deformation such as bulge of the cover (by applying a scale on it)
- Paint discoloring with heat
- Peeling

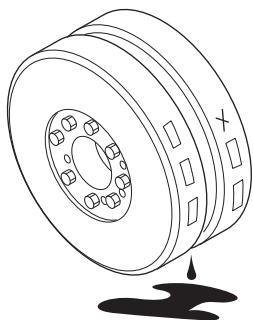

Fig. 8-13 Damper - Check

Note

- If the damper is defective, contact your MHIET dealer **"CONTACT LIST"** (→ [Page 10](#)).

Damper Temperature - Check

To ensure the proper function of damper, heat must be dissipated from its surface to prevent excessive heating.

Be sure to obey the instructions below:

- Make sure the temperature of the damper outside surface does not exceed the temperature described in the following table when operating the engine at the rated power output.
- When installing a protective cover to the damper, provide adequate ventilation so that the damper temperature does not exceed the temperature listed in the table below.

Table 8-4 Limit Temperature of Damper

Type of damper	Continuous use engine	Emergency use engine
Viscous damper	90°C [194°F]	100°C [212°F]

■ Temperature Control with Thermo Label

On the damper, a thermo label is attached as a guide.

When the thermo label reaches the specified temperature, the white heat-sensitive area turns black.

Control and record the temperature regularly, and check any abnormal temperature changes.

Note

- **Once the heat-sensitive area of the thermo label turns its color, it will never return to the original color again.**
- **A thermo label is attached as a guide. It is recommended to measure the temperature while operating the engine with a noncontact thermometer (thermo gun) and to control and record it accordingly.**

- 1 **Make sure with a noncontact thermometer (thermo gun, and others) that the surface of the engine is cooled down so that you can touch.**
- 2 **Stick a thermo label (1) onto the outer face of the damper.**

Note

- **Avoid the stamped marking.**

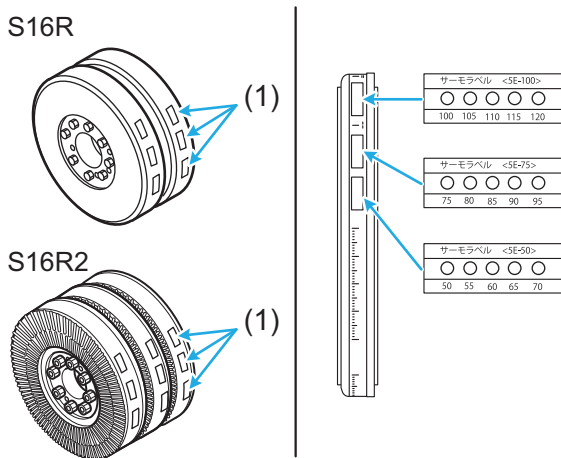

Fig. 8-14 Thermo Label - Stick

Table 8-5 Types of Thermo Labels

Part name	Measurable temperature range (°C)
Thermo label 100-120	100 to 120
Thermo label 75-95	75 to 95
Thermo label 50-70	50 to 70

- 3 **Operate the engine at the rated load for about an hour.**
- 4 **Operate the stop switch "Starting and Stopping Devices Installed during Manufacturing the Generator" ([→ Page 87](#)) of the generator to turn off the engine.**
- 5 **Check the heat-sensitive area of the thermo label and record the highest temperature.**

→If a temperature rise is observed, locate the defect in the engine or other causes. In addition, replace the thermo label with a new one and check the change of temperature again.

Note

- **If the detected temperature comes close to the limit temperature of the damper, or if there is any abnormal change in temperature, contact your MHIET dealer "[CONTACT LIST](#)" ([→ Page 10](#)).**
- **For the temperature limit of the damper, refer to "[Table 8-4 Limit Temperature of Damper](#)" ([→ Page](#)**

132).

Fuel System - Check

⚠ WARNING



Keep away from fire, when working with flammable substances such as fuel.

* They may cause a fire.

If fuel leaks or splashes out from the high pressure injection pipe, do not touch the fuel.

* The fuel injection pipe delivers high pressure fuel. If the fuel contacts your skin, it goes into deep skin tissues and may result in gangrene.



Wipe off spilled flammable substances such as fuel thoroughly with a waste cloth.

* They may cause a fire.

When discarding a waste cloth used to wipe off combustible material, put it into a lidded can and obey the Waste Management and Public Cleansing Act to handle it as a special industrial waste.

* It may cause a fire.

* It could lead to environmental pollution.

* If you violate rules, you may be subject to penalties.

Note

- **When handling fuel, refer to "[4 FUEL](#)" ([→ Page 104](#)).**
- **Devices and equipment outside the scope of our supply are included in the facility. For the details, refer to such a document as the specification sheet prepared by the generator supplier.**
- **For the devices and equipment outside the scope of our supply, refer the corresponding manual of the generator and the supplier's operation manual.**

Fuel tank - Check and Service

Clean and drain water from the fuel tank.

Note

- **The fuel tank is outside the scope of our supply. For the details, refer to the corresponding manual of the generator and the supplier's operation manual.**

■ Fuel Tank - Clean

⚠ WARNING



Tighten the fuel supply valve to the engine firmly.

- * Otherwise, fuel may leak out, which could cause a fire.

⚠ CAUTION



After cleaning the fuel tank, do not leave the used waste cloth in the fuel tank.

- * Otherwise, it may cause damage to the devices in the fuel system.



When draining fuel through the drain cock, always use a container which can accept all the fuel in the tank.

- * Otherwise, the drained fuel will overflow from the container and may run to outside of the facility.
- * The fuel drained into the container shall be discarded in accordance with the local laws and regulations as well as the manufacturer's SDS.

- 1 Clean the fuel tank.**
- 2 Refill fuel into the fuel tank, and bleed the fuel system "[Fuel System - Bleed Air](#)" (→ [Page 134](#)).**

■ Fuel Tank - Drain Water

⚠ CAUTION



When draining water from the fuel tank, always use a container which is suitable for the water quantity.

- * Otherwise, the drained water will overflow from the container and may run to outside of the facility.
- * The water drained into the container is contaminated with fuel. Discard the water in accordance with the local laws and regulations as well as the manufacturer's SDS.

Drain water properly from the fuel tank.

- * If water, dust or other foreign particles are left, they may mix with fuel, which could cause low output power or damage to the devices in the fuel system.

Drain water from the fuel tank.

Fuel System - Bleed Air

⚠ WARNING



Bleed air sufficiently from the fuel system.

- * Otherwise, starting failure may occur.

After bleeding, tighten the priming pump firmly.

- * If the tightening torque is too weak, fuel leak may occur.
- * If the tightening torque is too strong, the priming pump could be damaged.

While feeding fuel with the priming pump, bleed air from the location closest to the fuel tank, that is, in the order of the water separator, fuel filter, and fuel injection pump.

Note

- **Devices and equipment outside the scope of our supply are included in the facility. For the details, refer to such a document as the specifications sheet prepared by the generator manufacturer.**
- **For the devices and equipment outside the scope of our supply, refer the corresponding manual of the generator and the supplier's operation manual.**

■ Priming Pump - Operate

There are two different types (A-type and B-type) of priming pumps.

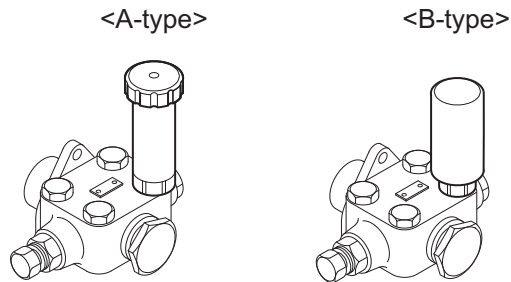

Fig. 8-15 Priming Pump

Note

- For the location of the priming pumps, refer to **"2 ENGINE - OUTLINE"** (→ Page 76).

<A-type>

1 Loosen the priming pump cap (1) by turning it counterclockwise.

→The cap (1) is released and the cap (1) is raised.

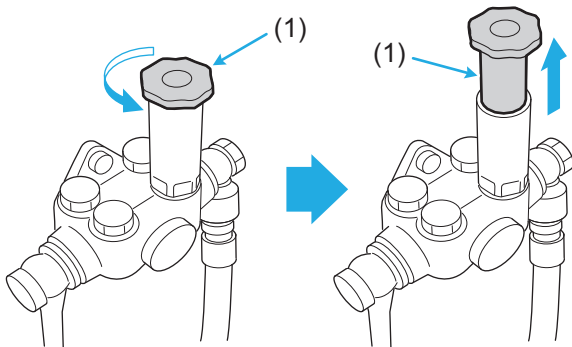

Fig. 8-16 Priming Pump - Operation <A-type>

2 Move the cap (1) up and down.

→Fuel is discharged.

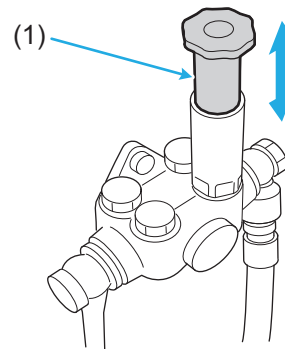

Fig. 8-17 Priming Pump - Operation <A-type>

3 After bleeding air, turn the cap (1) clockwise while pushing it.

- Make the cap (1) to contact with the head packing (2).

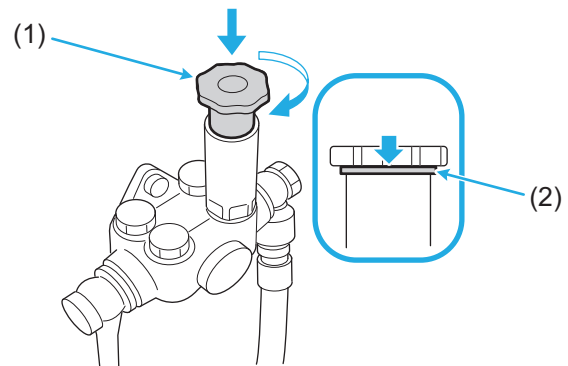

Fig. 8-18 Priming Pump - Operation <A-type>

4 Retightened by 80 to 100°.

- Tool: Adjustable wrench

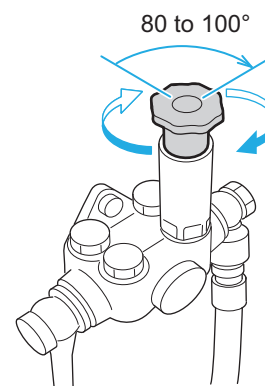

Fig. 8-19 Priming Pump - Operation <A-type>

- 5 **Check the head packing (3) for an abnormality such as deformation or scratches.**

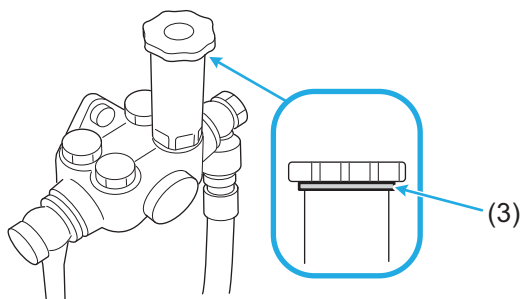

Fig. 8-20 Priming Pump - Operation <A-type>

Note

- **If the head packing has an abnormality such as deformation or scratches, the priming pump must be replaced. Contact your MHIET dealer "CONTACT LIST" (→ Page 10).**

<B-type>

- 1 **Move the handle up and down.**
→Fuel is discharged.

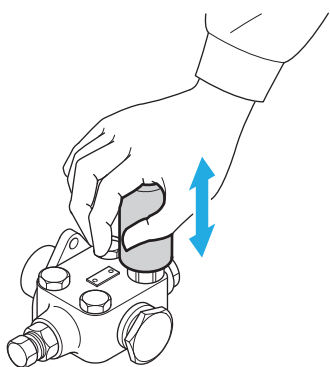

Fig. 8-21 Priming Pump - Operation <B-type>

Note

- **There is not a locking mechanism.**

■ **Water Separator - Bleed Air**

Bleed air from the water separator.

Note

- **The water separator is outside the scope of our supply. For the details, refer to such a document as the corresponding manual of the generator and the supplier's operation manual.**

■ **Fuel Filter - Bleed Air**

Bleed air from the fuel filter.

Note

- **For the location of the fuel filter, refer to "2 ENGINE - OUTLINE" (→ Page 76).**
- 1 **Loosen the air vent plug of the fuel filter by turning it counterclockwise.**
- Tool: Ring spanner

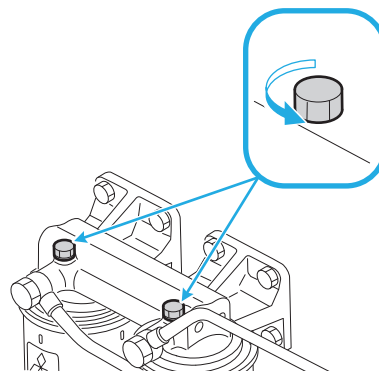

Fig. 8-22 Fuel Filter - Bleed Air (1)

- 2 **Operate the priming pump up and down to feed fuel. "Priming Pump - Operate" (→ Page 135)**
- 3 **Wipe off fuel seeped out from the air vent plug with a waste cloth.**
- 4 **Tighten the air vent plug of the fuel filter by turning it clockwise.**
- Tool: Torque wrench
 - Tightening torque: 7.8 to 9.8 N·m {0.8 to 1.0 kgf·m} [5.75 to 7.23 lbf·ft]

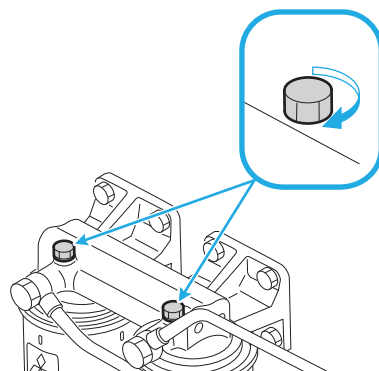

Fig. 8-23 Fuel Filter - Bleed Air (2)

■ Fuel Injection Pump - Bleed Air

Bleed air from the fuel injection pump.

Note

- For the location of the fuel injection pump, refer to "[2 ENGINE - OUTLINE](#)" ([→ Page 76](#)).

- 1 **Loosen the air vent plug of the fuel injection pump by turning it counterclockwise.**

- Tool: Ring spanner

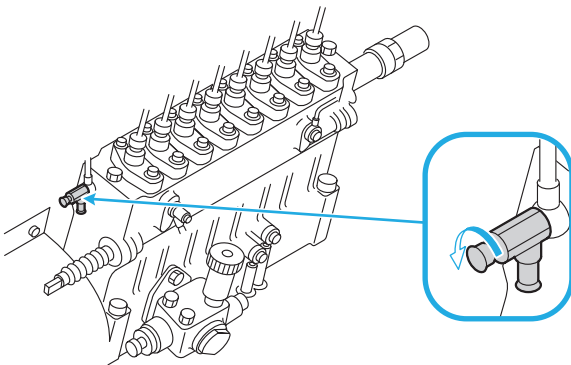

Fig. 8-24 Fuel Injection Pump - Bleed Air 1

- 2 **Connect a clear plastic tube onto the bleeder screw of the fuel injection pump, and place a container to receive fuel.**

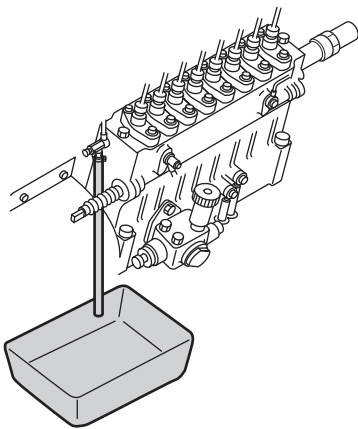

Fig. 8-25 Fuel Injection Pump - Bleed Air 2

Note

- Prepare a plastic tube (6 mm [0.24 in.] in diameter, approx. 2 m [78.74 in.] long).

- 3 **Operate the priming pump up and down to feed fuel "[Priming Pump - Operate](#)" ([→ Page 135](#)).**

- Feed fuel until the fuel free of bubbles flows from the air vent plug, while observing the plastic tube.

- 4 **Remove the plastic tube connected in Step 2, and discard fuel in the container properly.**

- 5 **Tighten the air vent plug of the fuel injection pump by turning it clockwise.**

- Tool: Torque wrench
- Tightening torque:
13 to 17 N·m {1.33 to 1.73 kgf·m}
[9.59 to 12.54 lbf·ft]

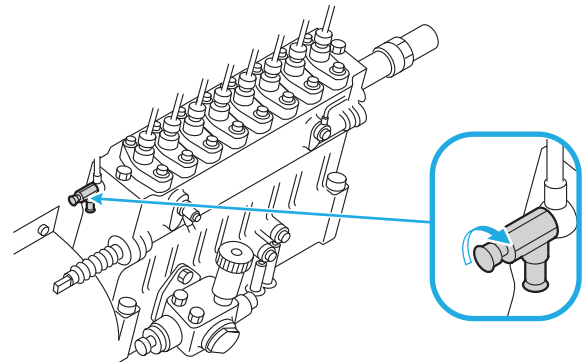

Fig. 8-26 Fuel Injection Pump - Bleed Air 3

Water Separator - Check and Service

Drain water from the water separator and replace its element.

Note

- **The water separator is outside the scope of our supply. For the details, refer to the corresponding manual of the generator and the supplier's operation manual.**

■ Water Separator - Drain Water

⚠ CAUTION



When draining water from the water separator, always use a container which is suitable for the water quantity.

- * Otherwise, the drained water will overflow from the container and may run to outside of the facility.
- * The water drained into the container is contaminated with waste oil. Discard the water in accordance with the local laws and regulations as well as the manufacturer's SDS.

Drain water properly from the water separator.

- * If draining the water separator is insufficient, water may enter into the fuel system, which could cause damage to the devices.

Drain water from the water separator.

■ Water Separator Element - Replace

⚠ WARNING



Open the inlet valve of the water separator slowly to prevent fuel in the water separator from spilling out. Wrap a cloth around the water separator.

- * Otherwise, spilled fuel may be ignited, which could cause a fire.

⚠ CAUTION



Tighten the cover and cock on the water separator appropriately.

- * If the tightening torque is too weak, fuel may leak, causing a fire or fuel flow-out, which could lead to environmental pollution.

- 1 Replace the water separator element.**
- 2 After the new fuel filter element is installed, bleed air from the fuel system. ["Fuel System - Bleed Air" \(→ Page 134\)](#)**

Gauze Filter - Clean

⚠ WARNING



Clean the gauze filter properly.

* A clogged gauze filter may result in insufficient fuel supply, low power output, or engine stall during operation.

⚠ CAUTION



When replacing the gauze filter, tighten the new one under the same condition as the old one was installed.

* If the tightening torque is too weak, fuel may leak, causing a fire or fuel flow-out, which could lead to environmental pollution.

Note

- For the location of the fuel supply pump, refer to "[2 ENGINE - OUTLINE](#)" ([→ Page 76](#)).
- Some parts such as joint and hose may be outside the scope of our supply. For the details, refer to such a document as the specification sheet prepared by the generator manufacturer.
- If it is not supplied by MHIET, follow the instructions in the supplier's operation manual.

1 Remove the banjo bolt at the inlet port of the fuel feed pump.

- Tool: Wrench

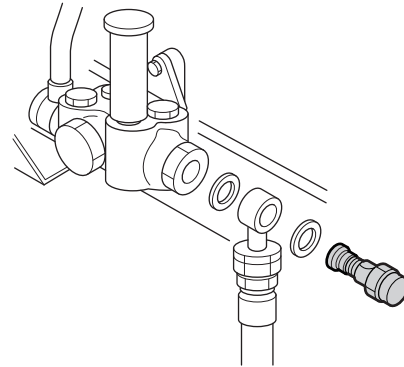

Fig. 8-27 Banjo Bolt - Remove

2 Remove the gauze filter that is fitted inside the banjo bolt.

- Tool: Flat blade screwdriver

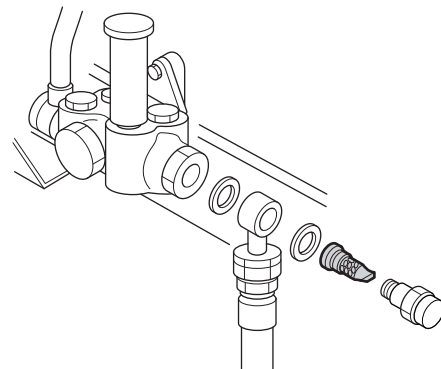

Fig. 8-28 Gauze Filter - Remove

3 Soak the gauze filter into fresh fuel oil in the container, and wash it with a soft brush or others.

- Replace the gauze filter with a new one, if it has a break or deformation.

4 After cleaning, install the gauze filter into the banjo bolt.

- Tool: Flat blade screwdriver

5 Align the phase and angle between the joint (1) and the hose (2) as they were when removed.

- Always replace the sealing washer with a new one once it is disturbed.

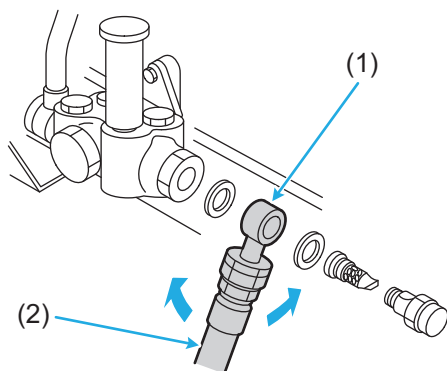

Fig. 8-29 Hose Joint

6 Install the banjo bolt in Step 4 to the fuel feed pump.

- Tool: Torque wrench
- Tightening torque:
30 to 38 N·m {3.06 to 3.87 kgf·m}
[22.13 to 28.03 lbf·ft]
- Always replace the sealing washer with a new one once it is disturbed.

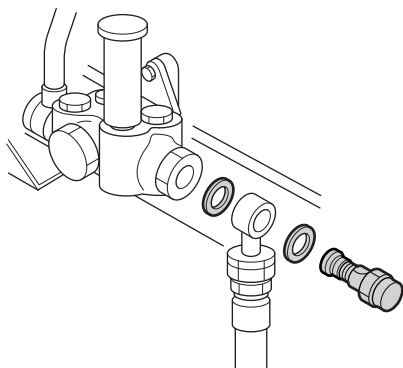

Fig. 8-30 Banjo Bolt - Install

7 Bleed air from the fuel filter "[Fuel Filter - Bleed Air](#)" (→ [Page 136](#)).

Fuel Filter - Replace

⚠ WARNING



Do not pour fuel into the fuel filter before installing it.

- * Otherwise, it may cause serious personal injury, environmental pollution due to fuel running to outside of the facility, or damage to the devices.
- * Follow the installation procedure described in this Operation & Maintenance Manual.



Use a genuine fuel filter.

- * If a non-genuine filter is used, deterioration in the exhaust gas properties and damage to the devices could occur due to insufficient air intake.
- * Failures or damages caused by using non-genuine parts will be outside the scope of the warranty.

⚠ CAUTION



Do not use a fuel filter with a scratch or dent.

- * Otherwise, damage to the filter or fuel leak may occur, which could cause a fire or environmental pollution due to fuel running to outside of the facility.

Do not use a filter wrench when installing the fuel filter.

- * It may cause a dent or damage to the fuel filter.



If fuel spills out while removing the fuel filter, wipe off with a waste cloth.

- * Otherwise, it may cause a fire or environmental pollution due to fuel running to outside of the facility.
- * The waste cloth used to wipe off fuel shall be discarded in according with the local laws and regulations as well as the manufacturer's SDS.

Check the specification of the fuel filter when installing it.

- * The fuel filter of which specification does not apply to the fuel may cause damage to the devices.

Note

- For the location of the fuel filter, refer to "[2 ENGINE - OUTLINE](#)" (→ [Page 76](#)).

- 1 Clean the area around the fuel filter with a waste cloth.**

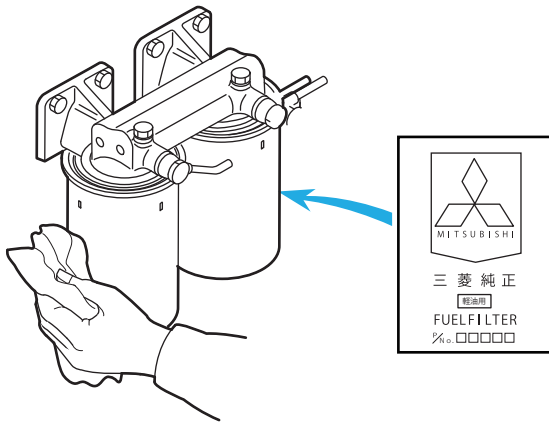

Fig. 8-31 Around Fuel Filter - Clean

- 2 Prepare a container to receive spilled fuel and place it under the fuel filter.**

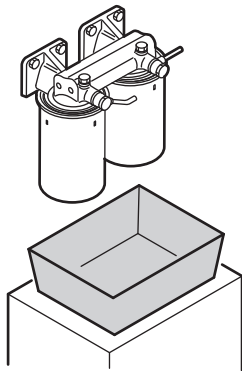

Fig. 8-32 Container to Receive Fuel

Note

- **The customer is required to prepare the container.**

- 3 Remove the fuel filter.**

- Tool: Filter wrench

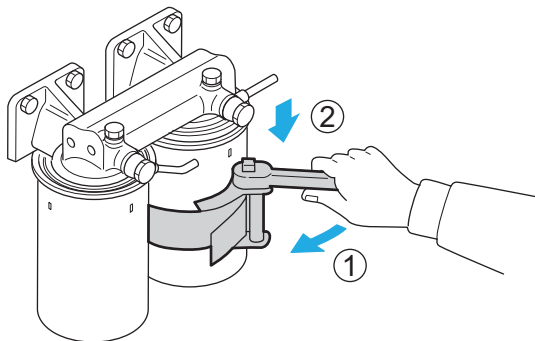

Fig. 8-33 Fuel Filter - Remove

Note

- **Remove it slowly so that fuel will not spill.**

- 4 Wipe off fuel on the fuel filter installing surface of the filter bracket with a waste cloth.**

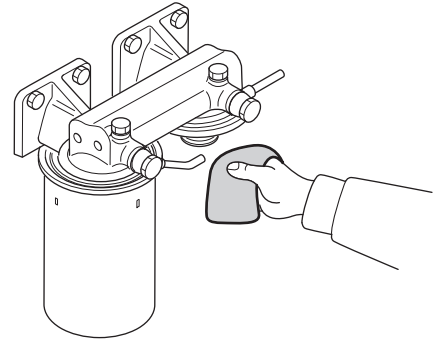

Fig. 8-34 Fuel Filter Installing Surface - Clean

- 5 Prepare a new fuel filter.**

- 1) Check that the gasket is properly seated in the groove.
- 2) Apply clean fuel on the fuel filter gasket.

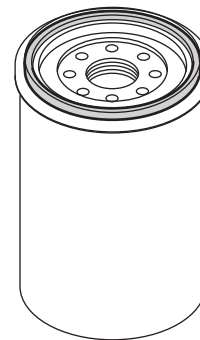

Fig. 8-35 Fuel Filter Gasket

6 Install the fuel filter in Step 5 on the filter bracket.

- When the fuel filter gasket comes in contact with the installing surface of the filter bracket, further tighten the fuel filter by 3/4 to a full turn.

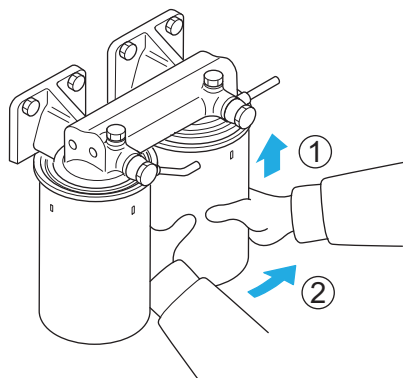

Fig. 8-36 Fuel Filter - Install

Note

- If the fuel filter is slippery and therefore hard to install, wipe the fuel filter surface with a waste cloth thoroughly, and tighten the fuel filter with anti-slip gloves.

7 Bleed air from the fuel filter "[Fuel Filter - Bleed Air](#)" (→ [Page 136](#)).

8 Check the fuel control link "[Fuel Control Link - Check](#)" (→ [Page 142](#)).

9 Operate the start switch of the generator "[Starting and Stopping Devices Installed during Manufacturing the Generator](#)" (→ [Page 87](#)) to start the engine.

10 Operate the engine at an idle speed for several minutes.

11 Operate "[Starting and Stopping Devices Installed during Manufacturing the Generator](#)" (→ [Page 87](#)) the stop switch of the generator to turn off the engine.

12 Check the fuel filter installing surface of the filter bracket for leakage.

- If a fuel leak is found, remove the fuel filter and check the gasket for damage.
- Replace the gauze filter with a new one, if it has damage.

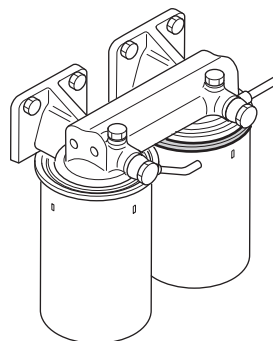

Fig. 8-37 Fuel Filter Installing Surface - Check

13 Discard fuel in the container in Step 2 properly.

Fuel Control Link - Check

⚠ WARNING

⊘ Never cut the seal of the fuel control link.

- * If you cut the seal, damage to the engine or deterioration in the exhaust gas properties could occur.
- * In case that the seal is cut, warranty will become invalid.

! Make sure there is no looseness or play at the fuel control link.

- * Otherwise, the engine may overrun.

⚠ CAUTION

⊘ When checking the fuel control link, do not insert your finger into the moving parts.

- * Otherwise, you may get injured.

Note

- For the location of the fuel control link, refer to "[2 ENGINE - OUTLINE](#)" (→ [Page 76](#)).

- 1 Check the fuel control link if it moves smoothly and is free of play and looseness.

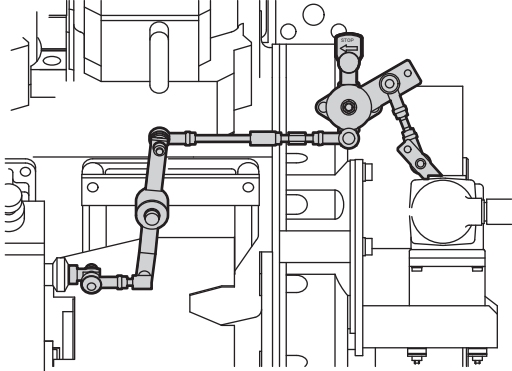

Fig. 8-38 Fuel Control Link - Check

Note

- If there is play or looseness, contact your MHIET dealer "[CONTACT LIST](#)" ([→ Page 10](#)).
- 2 Push the manual stop lever to the fuel increase direction and hold this position.

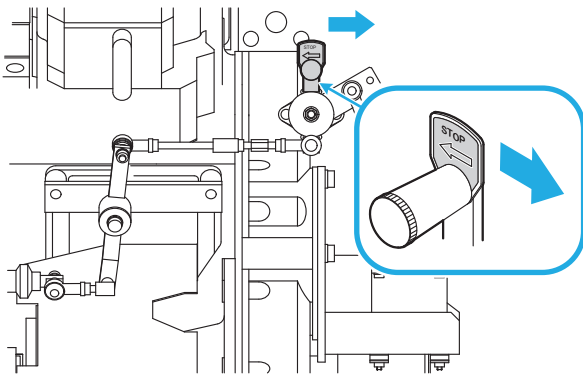

Fig. 8-39 Manual Stop Lever - Operate

Note

- The location of the manual stop lever varies depending on the specification of the engine. Refer to "[Protection System - Location](#)" ([→ Page 83](#)).

- 3 Decrease the pushing pressure little by little, and check the manual stop lever for smooth returning to the previous position.

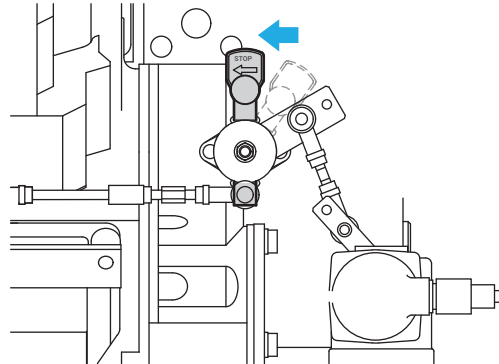

Fig. 8-40 Manual Stop Lever - Check

Note

- If the lever cannot be returned back smoothly, contact your MHIET dealer "[CONTACT LIST](#)" ([→ Page 10](#)).
- 4 Check the ball joint (1) for looseness of 0.1 mm [0.004 in.] or more.

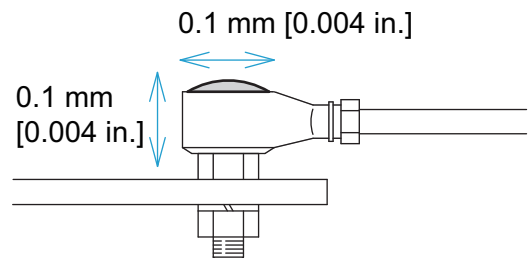
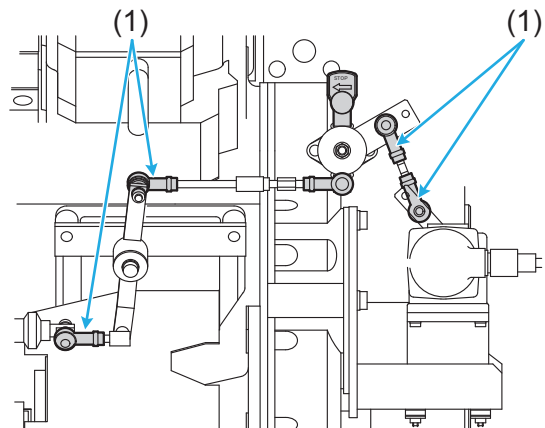

Fig. 8-41 Ball Joint - Check

Note

- If looseness is detected, replace the ball joint with a new one. "[Ball Joint - Replace](#)" ([→ Page 144](#))
- If the sealing is defective, contact your MHIET dealer "[CONTACT LIST](#)" ([→ Page 10](#)).

■ Ball Joint - Replace

Note

- If the ball joint is integrated with the control link, replace the assembly.

1 Remove the nut (or lock nut) which fixes the ball joint.

- Tool: Wrench

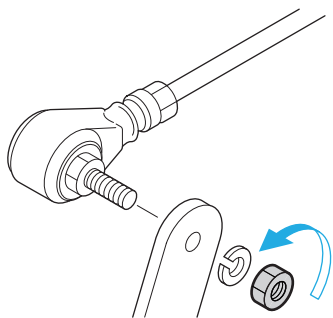

Fig. 8-42 Ball Joint - Remove

2 Ball Joint and Washer - Remove

- The lock nut does not have a washer.

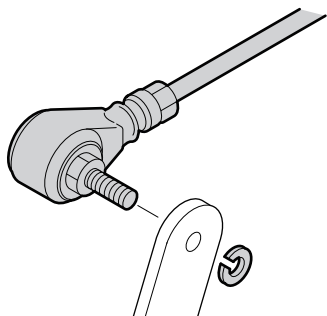

Fig. 8-43 Ball Joint and Washer - Remove

3 Install the new ball joint, and insert the washer.

- Replace the washer with a new one.

4 Tighten the nut, and fix the ball joint.

- Replace the nut with a new one.
- Tool: Wrench

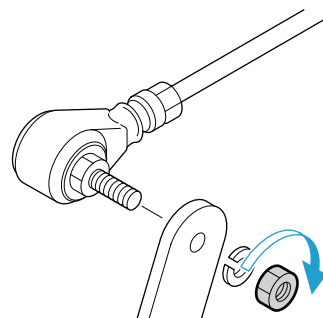

Fig. 8-44 Ball Joint - Fix

Fuel Pipe - Check

⚠ WARNING



Check the clamp for the high pressure fuel injection pipe for looseness.

- * If looseness or play is detected at the clamp for the high pressure fuel injection pipe, damage to the pipe may occur, which could cause a fire.

Install the clamp for the high pressure fuel injection pipe at the correct position.

- * If it is installed at a wrong position, the pipe could be damaged, which could cause a fire.

1 Check the clamp (1) and the seat (2) for cracks and wear.

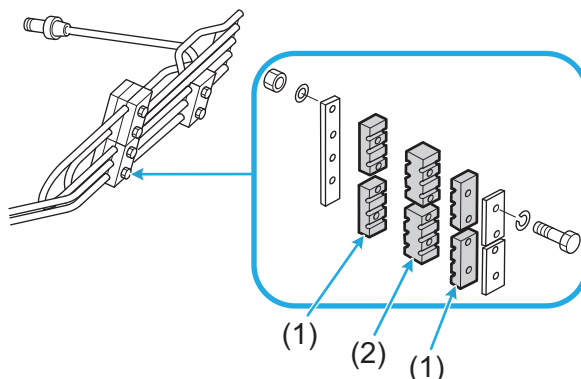

Fig. 8-45 Clamp and Seat - Check

Note

- If there are cracks or wear, contact your MHIET dealer "[CONTACT LIST](#)" ([→ Page 10](#)).

2 Install the clamp for the high pressure fuel injection pipe at the previous position. "[Fig. 8-46 High Pressure Fuel Injection Pipe Clamp - Location](#)" ([→ Page 145](#))

Engine Right Side View

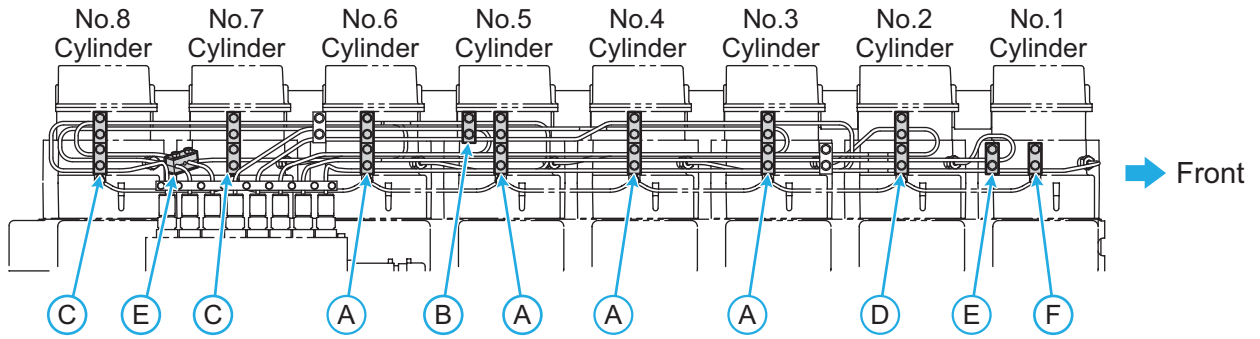

Engine Left Side View

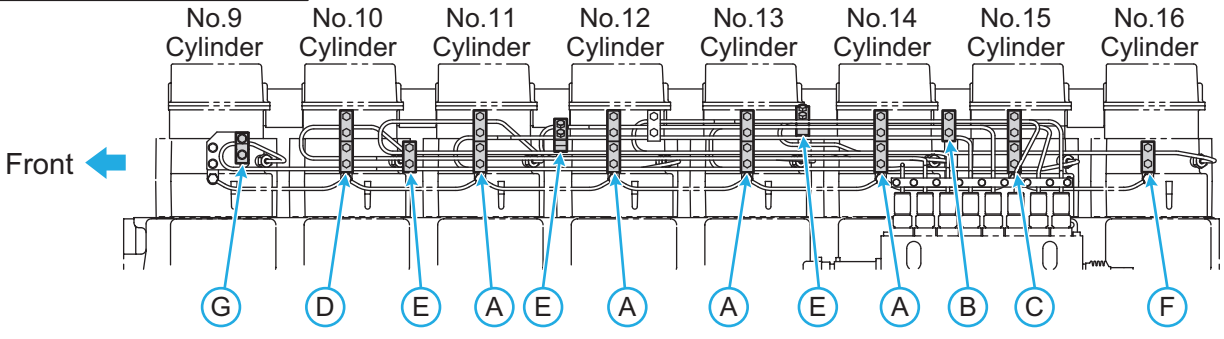

Position A

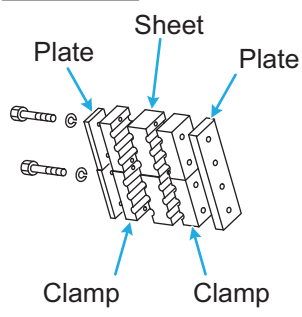

Position B

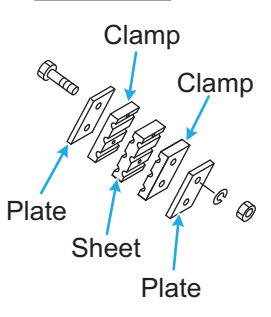

Position C

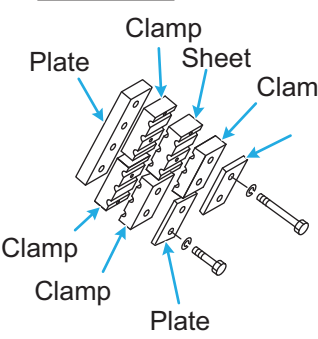

Position D

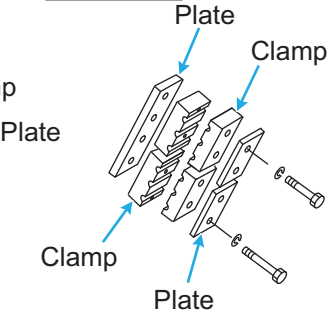

Position E

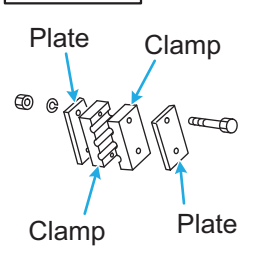

Position F

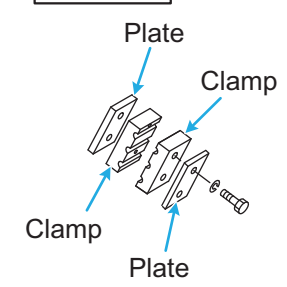

Position G

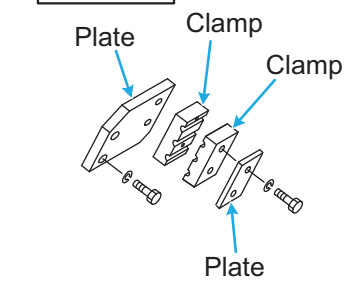

Fig. 8-46 High Pressure Fuel Injection Pipe Clamp - Location

3 Check the high pressure fuel injection pipe (3) for wear.

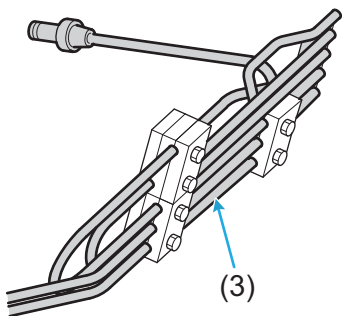

Fig. 8-47 High Pressure Fuel Injection Pipe - Check

Note

- If wear is found, contact your MHIET dealer **"CONTACT LIST"** (→ Page 10).

4 Loosen clamp retaining bolt and check wear of clip (4) and metal contact between the pipe and the clamp.

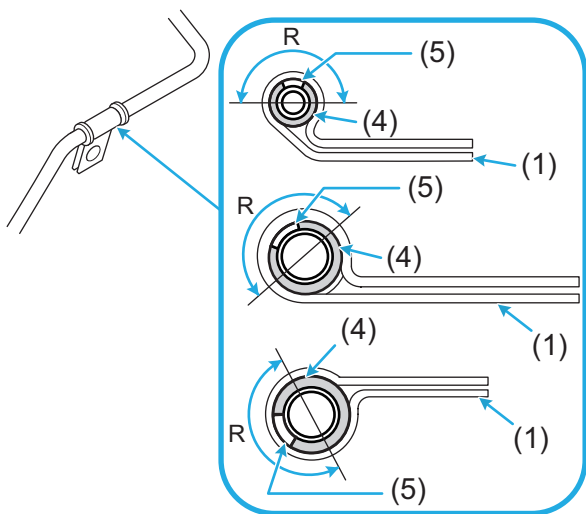

Fig. 8-48 Clip Attaching Direction

Note

- Attach the clip to the clamp by facing the position of the notch (5) of the clip (4) toward the R side of the clamp (1).

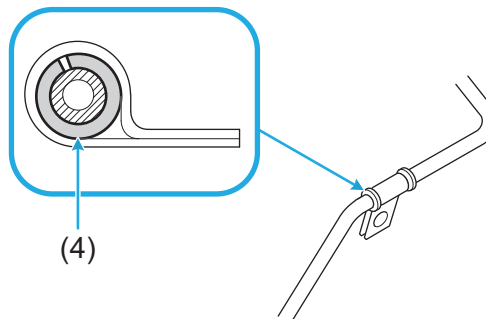

Fig. 8-49 Low Pressure Fuel Pipe - Check

Note

- If wear or metal contact is found, contact your MHIET dealer **"CONTACT LIST"** (→ Page 10).

Engine Oil System - Check

⚠ WARNING

- ⊘ Do not touch hot engine oil or parts.
* Otherwise, you could get burned.

Do not discard waste oil into sewerage, river, lake or other similar places.

- * Be sure to discard waste oil in accordance with the applicable laws and regulations.

Note

- When handling engine oil, refer to **"5 ENGINE OIL"** (→ Page 110).
- Devices and equipment outside the scope of our supply are included in the facility. For the details, refer to such a document as the specification sheet prepared by the generator supplier.
- For the devices and equipment outside the scope of our supply, refer the corresponding manual of the generator and the supplier's operation manual.
- If automatic oil supply is provided, refer to the corresponding manual of the generator and the supplier's operation manual.

Engine Oil - Change

■ Corresponding Equipment - Location

Examples of corresponding equipment at the engine side are given as follows. For the actual location, refer to "[2 ENGINE - OUTLINE](#)" (→ [Page 76](#)).

Table 8-6 Corresponding Equipment

No.	Name
(1)	Cylinder head
(2)	Oil level gauge
(3)	Oil filler
(4)	Oil pan

<S16R-Y1PTA - Right-Side View>

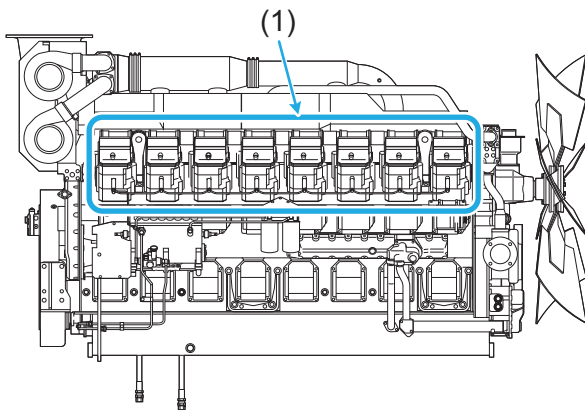

Fig. 8-50 <S16R-Y1PTA - Right-Side View>

<S16R-Y1PTA - Left-Side View>

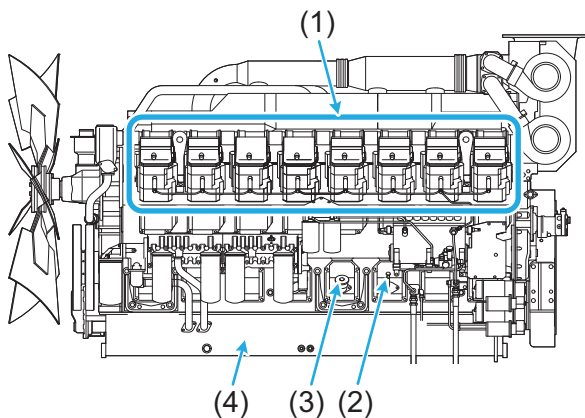

Fig. 8-51 <S16R-Y1PTA - Left-Side View>

■ Engine Oil - Drain

- 1 Operate the stop switch of the generator "[Starting and Stopping Devices Installed during Manufacturing the Generator](#)" (→ [Page 87](#)) to turn off the engine.
 - 2 Prepare a container of the suitable size for receiving drained engine oil, and place it under the oil pan drain port.
- Note**
- The customer is required to prepare the container.
- 3 Drain engine oil from the oil pan drain port.
 - 4 Discard engine oil in the container in Step 2 properly.

■ Engine Oil - Check

⚠ WARNING



Conduct analysis of the engine oil periodically and check to make sure that the engine oil does not show milky color.

* If the engine oil shows milky color, water may be mixed into the engine oil system due to coolant leak or a damaged cylinder liner O-ring. Use of the engine without any remedy could cause seizure of the crankshaft and lead to serious damage to the devices.

- 1 Extract 1 to 2 L [0.26 to 0.53 US gal.] of engine oil from the oil pan.
- 2 Check for odor and discoloration to determine if the oil is contaminated with fuel or water.
 - If fuel is mixed, the oil will smell like fuel.
 - If water is mixed, the engine oil becomes milky.

Note

- If the engine oil is contaminated with fuel or water, contact your MHIET dealer "[CONTACT LIST](#)" (→ [Page 10](#)).

■ Engine Oil - Refill

⚠ WARNING



Be sure to install the oil filler cap after engine oil is refilled.

* Otherwise, seizure due to insufficient oil or environmental pollution due to engine oil running out from the facility may occur.

Make sure that engine oil is not leaking from the oil pan. When checking the engine oil level, wear protective glasses to prevent engine oil from getting in your eyes.

* If engine oil gets in your eyes, it will cause pain and lead to sight loss at the worst.

Refill engine oil enough to raise the level to within the specified range (between the highest line {H} and the lowest line {L}).

* If the engine oil level exceeds the upper limit, the oil pan may crack or oil may splash out from the breather.

* If the engine oil level is too low, seizure of the bearings could occur.

Keep the quantity and properties (viscosity) of the engine oil at the specified level.

* If the supply or kinematic viscosity of engine oil is too low, insufficient lubrication of the bearing could occur, which could cause seizure of the crankshaft.

* If kinematic viscosity of engine oil increases, fuel consumption will increase.

1 Remove the oil filler cap.

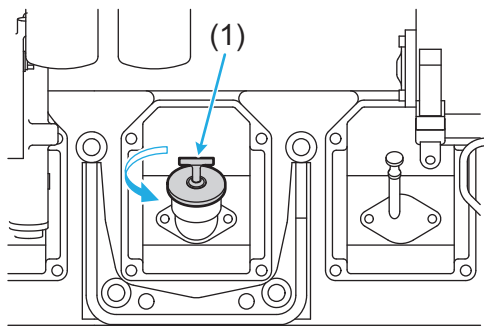

Fig. 8-52 Oil Filler Cap - Remove

2 Refill engine oil to the specified level.

- Tool: Hand pump, and others.

Note

- For the specified quantity of engine oil, refer to "[SPECIFICATIONS - CHECK](#)" (→ [Page 12](#)).

3 Remove the rocker cover from all the cylinder heads.

- Tool: Wrench

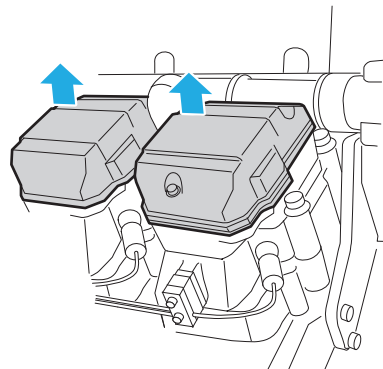

Fig. 8-53 Rocker Cover - Remove

4 Apply engine oil on the valve mechanisms of all the cylinder heads.

- Tool: Oiler, oil jug, and others.

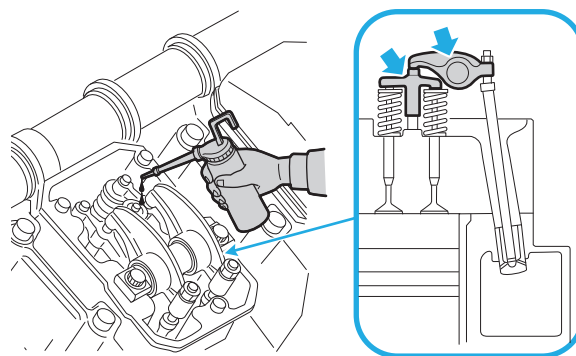

Fig. 8-54 Engine Oil - Apply (Valve Mechanism)

5 Apply engine oil to the camshaft oil baths of all the cylinder heads.

- Apply oil through the cylinder heads.
- Oil capacity per cylinder: 0.8 L [0.21 US gal.] (as a guide)
- Tool: Oiler, oil jug, and others.

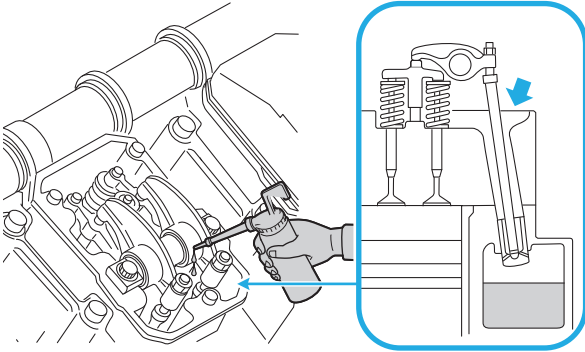

Fig. 8-55 Engine Oil - Apply (Camshaft Oil Bath)

6 Install the rocker covers onto all the cylinder heads.

- Tool: Wrench

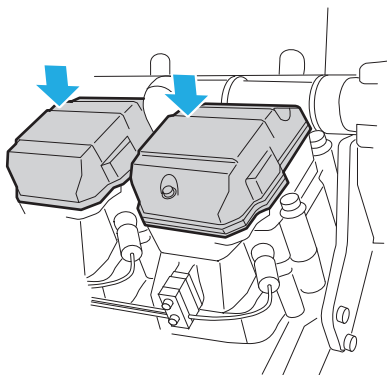

Fig. 8-56 Rocker Cover - Install

■ Engine Oil Level - Check

⚠ WARNING



Keep away from fire, when checking the engine oil level.

* It may cause a fire.

After filling engine oil, check and adjust the engine oil level.

- 1 **Check the specified level of the engine oil. "[SPECIFICATIONS - CHECK](#)" (→ [Page 12](#))**
- 2 **Pull out the oil level gauge (1) slowly and wipe off the engine oil with a waste cloth.**

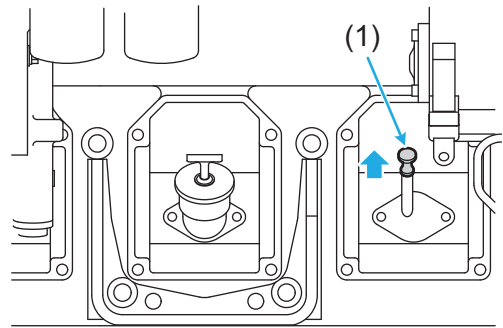

Fig. 8-57 Engine Oil Level - Check

- 3 **Insert the oil level gauge fully into the oil level gauge guide and then pull it out slowly.**

4 Check the level of the engine oil on the oil level gauge.

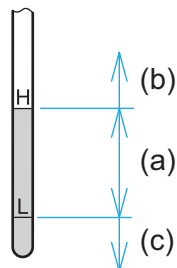

Fig. 8-58 Oil Level Gauge

- If the engine oil level is between the "maximum line (H)" and the "minimum line (L)", it is normal.
- If the engine oil level is higher than the "maximum line (H)", drain the oil. ["Engine Oil - Drain"](#) (→ [Page 147](#))
- If the engine oil level is lower than the "minimum line (L)", add the specified engine oil. ["Engine Oil - Refill"](#) (→ [Page 148](#))

5 After adjusting the engine oil level, install the oil filler cap (2).

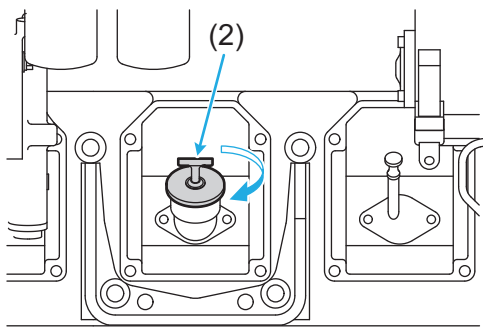

Fig. 8-59 Oil Filler Cap - Install

6 Check that the oil pan drain port is closed.

7 Check the engine oil system including the oil pan for leak of engine oil.

Note

- If a leak is found, contact your MHIET dealer ["CONTACT LIST"](#) (→ [Page 10](#)).

■ Engine - Adjust after Oil Change

After changing engine oil, operate the engine as follows.

- Pull the manual stop lever in the direction of stopping and hold this position, and crank the engine for approx. 10 seconds using the starter.**

→Engine oil is supplied to the engine parts.

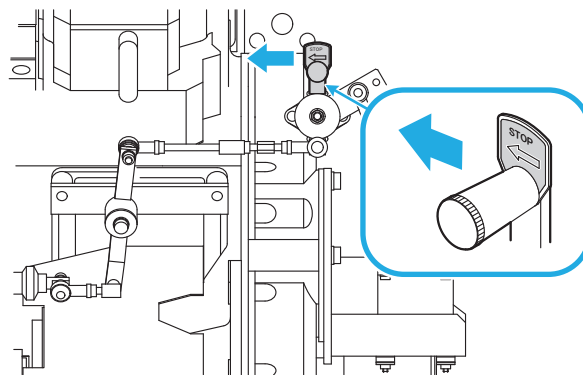

Fig. 8-60 Engine - Adjust after Oil Change

Note

- The location of the manual stop lever varies depending on the specification of the engine. Refer to ["Protection System - Location"](#) (→ [Page 83](#)).

- Pause for about 1 minute.**

- Repeat the operation of Step 1 and 2 for 2 or 3 times.**

→The engine oil reaches the engine parts.

- Check the engine oil level.** ["Engine Oil Level - Check"](#) (→ [Page 149](#))

Oil Filter - Replace

⚠ WARNING



When replacing the oil filter, do not pour the remaining engine oil in the old filter into the new filter.

* Otherwise, foreign particles could enter the engine oil system, which could cause damage to the devices.



Before replacing the oil filter, make sure that the engine has cooled down to the normal temperature.

* Otherwise, you could get burned by heat.

Use a genuine oil filter.

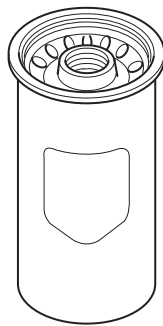

* Using non-genuine parts could cause damage to the devices or degradation in the performance.

* Failures or damages caused by using non-genuine parts will be outside the scope of the warranty.

If paint or other matter is adhering around the sealing surface, remove them before assembling.

* If paint or other matter is stuck on the sealing surface, fuel could leak through the gap, which could cause a fire.

If engine oil spills out while removing the oil filter, wipe off with a waste cloth.

* Otherwise, it may cause a fire or environmental pollution due to fuel running to outside of the facility.

* The waste cloth used to wipe off engine oil shall be discarded in according with the local laws and regulations as well as the manufacturer's SDS.

⚠ CAUTION



Do not use the oil filter with a scratch or dent.

* Otherwise, damage to the filter or oil leak may occur, which could cause a fire or environmental pollution due to fuel running to outside of the facility.

Do not use a filter wrench when installing the oil filter.

* It may cause a dent or damage to the oil filter.



When replacing the oil filter, set the gasket into the groove properly.

* Otherwise, engine oil leak could occur, which could cause a fire or environmental pollution due to oil running to outside of the facility.

* Follow the replacing procedure described in this Operation & Maintenance Manual.

Note

- For the location of the oil filter, refer to **"2 ENGINE - OUTLINE"** (→ [Page 76](#)).

- 1 **Clean the area around the oil filter, with a waste cloth.**

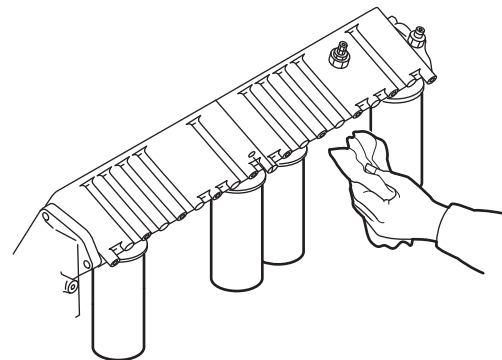

Fig. 8-61 Around Oil Filter - Clean

- 2 Prepare a container to receive spilled oil and place it under the oil filter.**

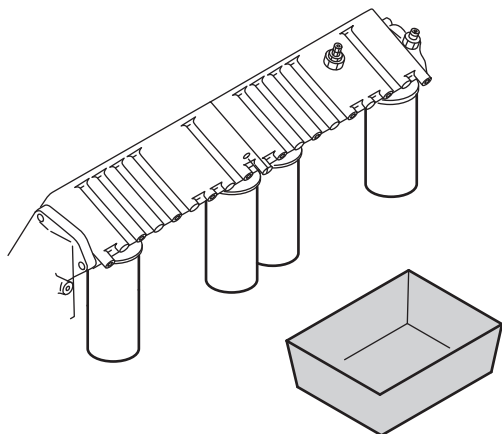

Fig. 8-62 Container to Receive Engine Oil

Note

- **The customer is required to prepared the container.**

- 3 Remove the oil filter.**

- Tool: Filter wrench

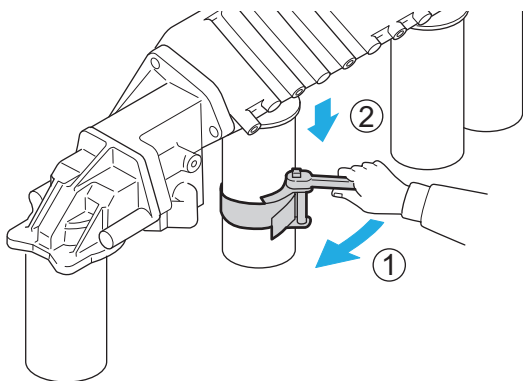

Fig. 8-63 Oil Filter - Remove

Note

- **Remove it slowly so that engine oil will not spill.**
- **Cut the removed oil filter and check the element. If metal particles are found, contact your MHIET dealer "[CONTACT LIST](#)" (→ [Page 10](#)).**

- 4 Thoroughly wipe off engine oil on the oil filter installing surface of the filter bracket with a waste cloth.**

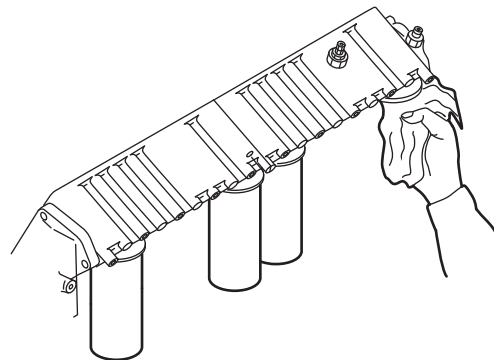

Fig. 8-64 Oil Filter Installing Surface - Clean

- 5 Prepare a new oil filter.**

- 1) Check that the gasket is properly seated in the groove.
- 2) Apply clean engine oil to the gasket.

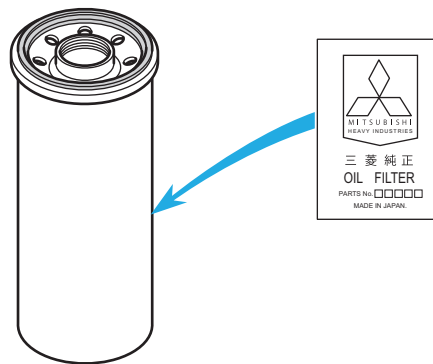

Fig. 8-65 Oil Filter Gasket

- 6 Install the oil filter in Step 5 on the filter bracket.**

- When the oil filter gasket comes in contact with the installing surface of the filter bracket, further tighten the oil filter by 3/4 to a full turn.

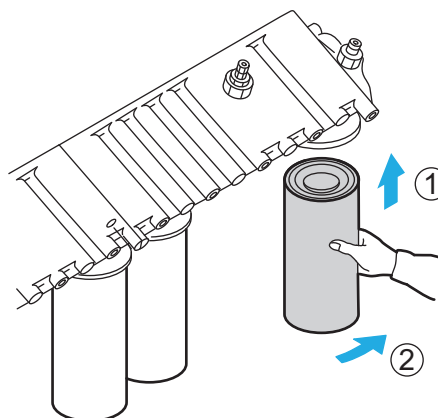

Fig. 8-66 Oil Filter - Install

Note

- If the oil filter is slippery and therefore hard to install, wipe the oil filter surface with a waste cloth thoroughly, and tighten the oil filter with anti-slip gloves.

Bypass Oil Filter - Replace

Replace using the same procedure as "[Oil Filter - Replace](#)" (→ [Page 151](#)).

Note

- For the location of the bypass oil filter, refer to "[2 ENGINE - OUTLINE](#)" (→ [Page 76](#)).

Governor Oil Filter - Replace (Hydraulic Governor Spec)**⚠ WARNING**

Do not touch hot engine oil or parts.

* Otherwise, you could get burned.

- 1 Clean the area around the governor oil filter, with a waste cloth.**
- 2 Prepare a container to receive spilled oil and place it under the governor oil filter.**

Note

- The customer is required to prepare the container.

- 3 Drain engine oil in the governor oil filter.**

- Tool: Wrench
 - 1) Loosen the air vent plug (1).
 - 2) Remove the drain plug (2).
 →Engine oil is drained.

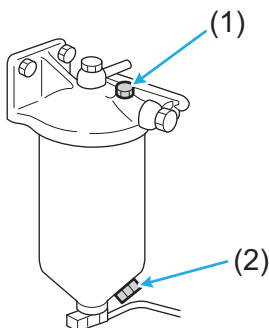

Fig. 8-67 Engine Oil - Drain

- 4 Remove the oil pipe (3) from center bolt.**

- Tool: Wrench

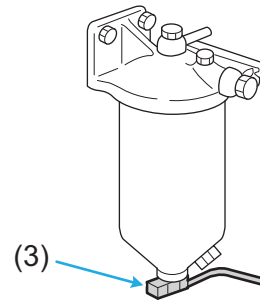

Fig. 8-68 Oil Pipe - Remove

- 5 Remove the center bolt (4).**

→The case (5) can be removed.

- Tool: Wrench

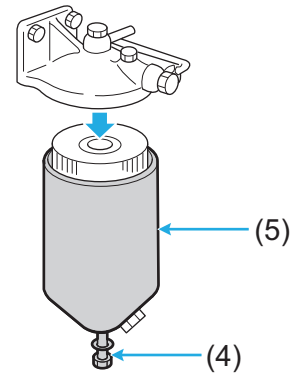

Fig. 8-69 Center Bolt - Remove

- 6 Pull out the element from the case.**

Note

- Pull it out slowly so that engine oil will not spill.

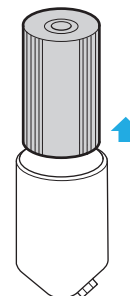

Fig. 8-70 Element - Pull Out

7 Install a new element in the case along the center bolt.

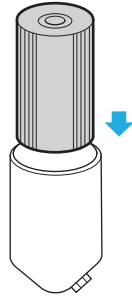

Fig. 8-71 Element - Install

8 Install the case (5) in Step 7 to the filter bracket. Fix it by tightening the center bolt (4).

- Tool: Wrench

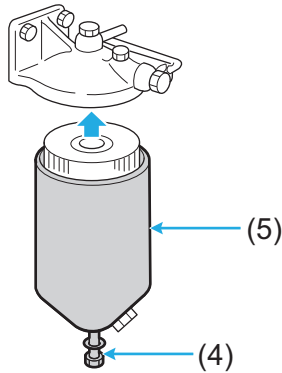

Fig. 8-72 Case - Install

9 Install the oil pipe (3) was removed in Step 4.

- Tool: Wrench

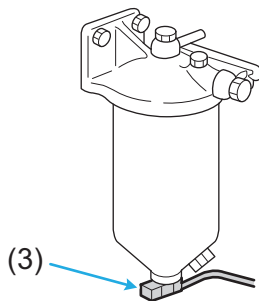

Fig. 8-73 Oil Pipe - Install

10 Install the drain plug (2) which was removed in Step 3.

- Tool: Wrench

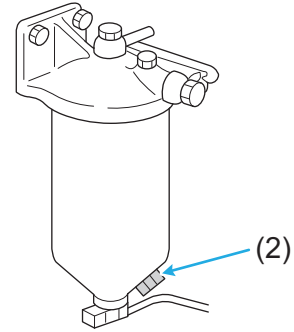

Fig. 8-74 Drain Plug - Install

11 Remove the air vent plug (1).

- Tool: Ring spanner

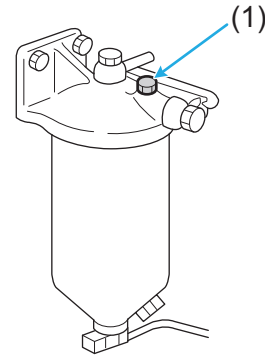

Fig. 8-75 Air Vent Plug - Remove

12 After filling the filter with engine oil, install the air vent plug (1).

- Tool: Wrench

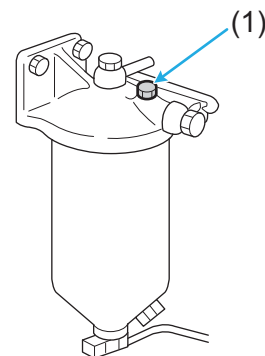

Fig. 8-76 Air Vent Plug - Install

Oil Pipe - Check

Loosen the clamp retaining bolt of the oil pipe and check for wear of the clip (1) and metal contact between the pipe (4) and the clamp.

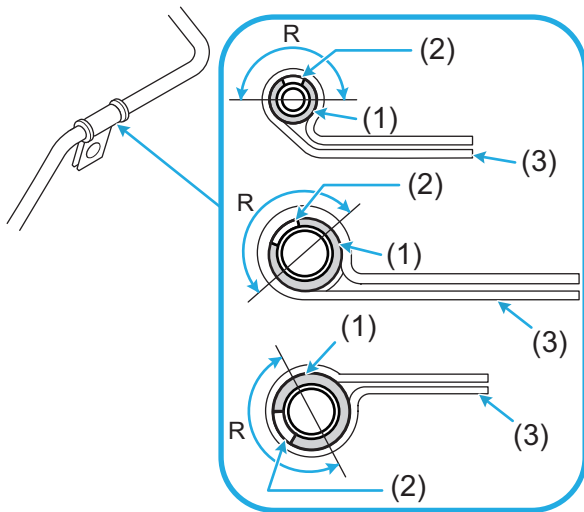

Fig. 8-77 Clip Attaching Direction

Note

- **Attach the clip to the clamp by facing the position of the notch (2) of the clip (1) toward the R side of the clamp (3).**

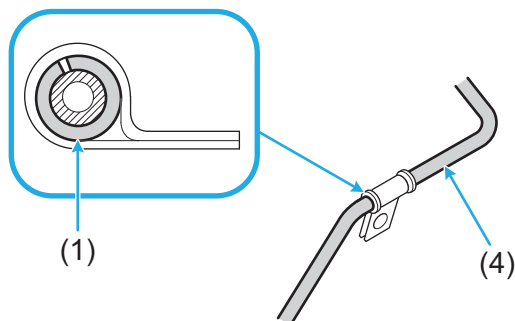

Fig. 8-78 Oil Pipe - Check

Note

- **If wear is found, contact your MHIET dealer "[CONTACT LIST](#)" (→ [Page 10](#)).**

Cooling System - Check

⚠ WARNING

- ⊘ **Do not continue to operate the engine with engine oil mixed in coolant.**

* Otherwise, cooling failure may occur, which could cause damage to the engine.

Do not open the radiator cap or coolant tank cap while the engine is hot.

* Otherwise, you could get burns by steam or water splashing out.

- ⚠ **Tighten the drain cock on the water pump properly.**

* Insufficient tightening may cause a coolant leak.

⚠ CAUTION

- ⚠ **Follow the coolant draining procedure described in this Operation & Maintenance Manual.**

* Draining in the incorrect procedure may cause burns or environmental pollution due to coolant running to outside of the facility.

When handling cleaning solution for washing the cooling system, obey the manufacturer's SDS.

* Improper wearing or using of personal protective equipment may cause personal injury.

Note

- **When handling coolant (LLC), refer to "[6 COOLANT](#)" (→ [Page 112](#)).**
- **Devices and equipment outside the scope of our supply are included in the facility. For the details, refer to such a document as the specification sheet prepared by the generator supplier.**
- **For the devices and equipment outside the scope of our supply, refer the corresponding manual of the generator and the supplier's operation manual.**

Corresponding Equipment - Location

Examples of corresponding equipment at the engine side are given as follows. For the actual location, refer to "[2 ENGINE - OUTLINE](#)" (→ [Page 76](#)).

Table 8-7 Corresponding Equipment - Location

Part	Name
(1)	Coolant drain cock (engine body)
(2)	Thermostat
(3)	Water pump

<S16R-Y1PTA - Right-Side View>

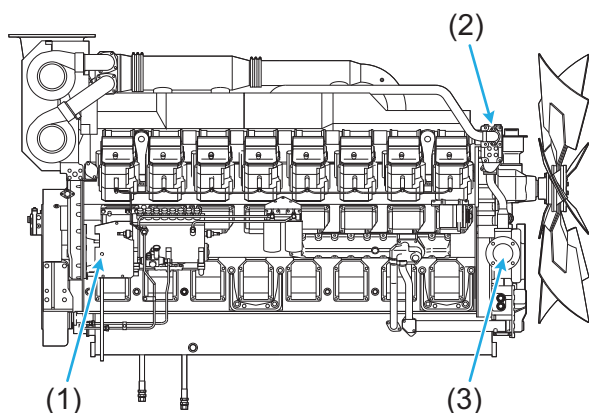

Fig. 8-79 <S16R-Y1PTA - Right-Side View>

<S16R-Y1PTA - Left-Side View>

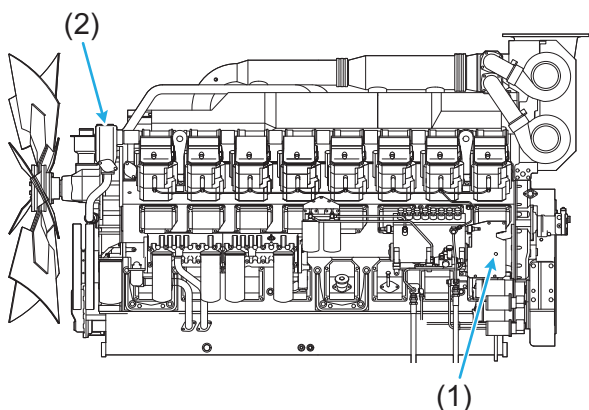

Fig. 8-80 <S16R-Y1PTA - Left-Side View>

Coolant - Change

■ Coolant - Drain

Note

- **When draining coolant immediately after engine operation, run the engine at low idle for 5 to 6 minutes and check that the coolant becomes to the room temperature.**

- 1 **Prepare a container for receiving drained coolant and place it under the coolant drain cock on the engine body.**

Note

- **The customer is required to prepare the container.**

- 2 **Slightly open the coolant drain cock (1) on the engine body.**

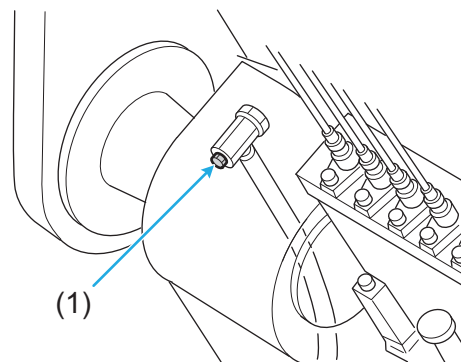

Fig. 8-81 Coolant Drain Cock on Engine Body

- 3 **Connect a clear plastic tube (3) to the coolant drain cock (2) on the water pump and fix with a band.**

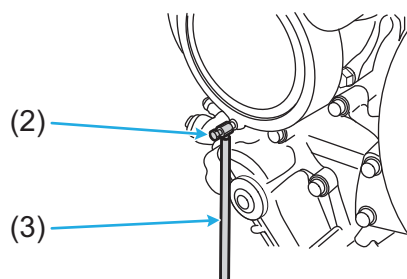

Fig. 8-82 Coolant Drain Cock on Water Pump

Note

- **Prepare a plastic tube (5 mm [0.20 in.] in diameter, approx. 1 m [39.37 in.] long) and a band.**

- 4 Prepare a container for receiving drained coolant and place it under the coolant drain cock on the water pump.**

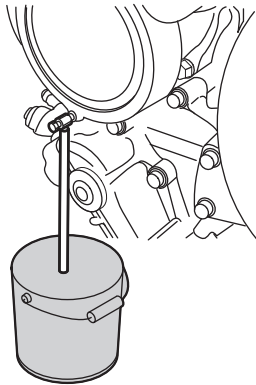

Fig. 8-83 Container to Receive Coolant

Note

- **The customer is required to prepare the container.**

- 5 Slightly open the coolant drain cock (2) on the water pump.**

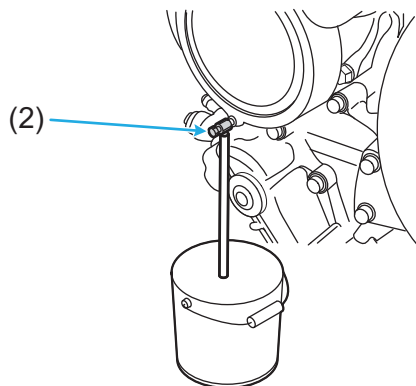

Fig. 8-84 Coolant Drain Cock on Water Pump

- 6 Slightly open the coolant filler port to release pressure.**

- If the radiator cap has a pressure release lever, move the lever upward to release pressure.

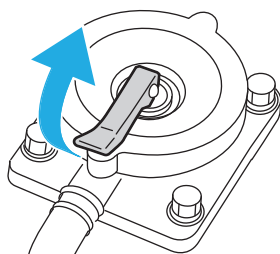

Fig. 8-85 Radiator Cap - Pressure Release (With Lever)

- If the radiator cap does not have a pressure release lever, cover the radiator cap with a waste cloth, and loosen the radiator cap a half-turn to release pressure.

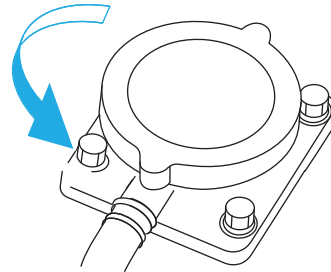

Fig. 8-86 Radiator Cap - Pressure Release (Without Lever)

- 7 Open the coolant drain cock (1) on the engine body.**

→Coolant is drained.

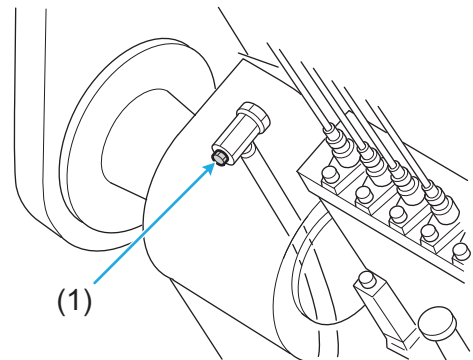

Fig. 8-87 Coolant Drain Cock on Engine Body

- 8 Open the coolant drain cock (2) on the water pump.**

→Coolant is drained.

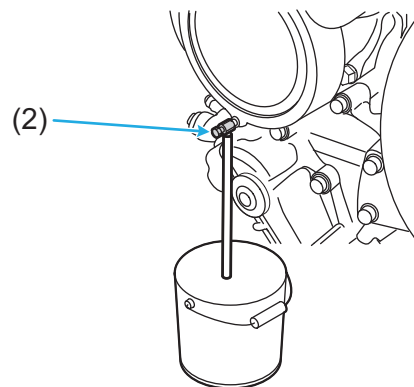

Fig. 8-88 Coolant Drain Cock on Water Pump

■ Cooling System - Clean

⚠ CAUTION



When handling cleaning solution for washing the cooling system, obey the manufacturer's SDS.

* Improper wearing or using of personal protective equipment may cause personal injury.

When using the engine or radiator for the first time or after a long term storage, clean the cooling system.

- 1 Close the coolant drain cock (1) and (2) on the engine body and water pump.**

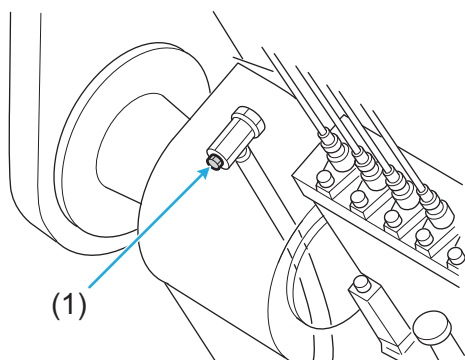

Fig. 8-89 Coolant Drain Cock on Engine Body

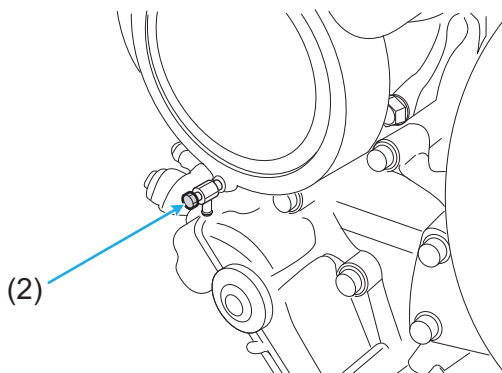

Fig. 8-90 Coolant Drain Cock on Water Pump

- 2 Pour cleaning solution (non-corrosive to rubber and metals) into the cooling system through the cooling filler cap.**
- 3 Operate the start switch of the generator ["Starting and Stopping Devices Installed during Manufacturing the Generator"](#) (→ [Page 87](#)) to start the engine.**
- 4 Operate the engine at the rated speed for about 15 minutes.**
- 5 Operate the stop switch of the generator ["Starting and Stopping Devices Installed during Manufacturing the Generator"](#) (→ [Page 87](#)) to turn off the engine.**
- 6 Prepare a container for receiving drained coolant and place it under the coolant drain cock on the engine body.**

Note

- **The customer is required to prepare the container.**

- 7 Connect a clear plastic tube (3) to the coolant drain cock (2) on the water pump and fix with a band.**

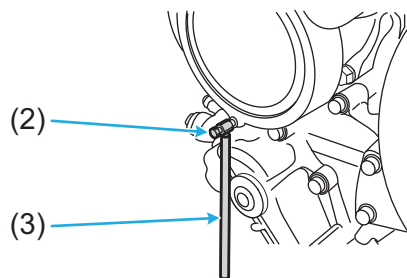

Fig. 8-91 Coolant Drain Cock on Water Pump

Note

- **Prepare a plastic tube (5 mm [0.20 in.] in diameter, approx. 1 m [39.97 in.] long) and a band.**

- 8 Prepare a container for receiving drained cleaning solution and place it under the coolant drain cock on the water pump.**

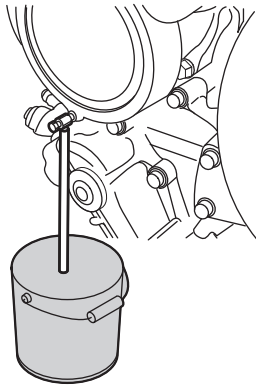

Fig. 8-92 Container to Receive Tap Water

Note

- **The customer is required to prepare the container.**

- 9 Open the coolant drain cock (1) and (2) on the engine body and water pump.**

→The cleaning solution poured in Step 2 is drained.

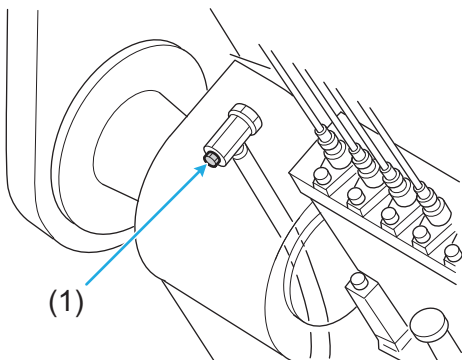

Fig. 8-93 Coolant Drain Cock on Engine Body

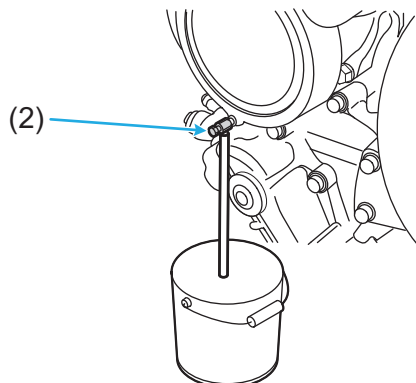

Fig. 8-94 Coolant Drain Cock on Water Pump

- 10 Close the coolant drain cock (1) and (2) on the engine body and water pump.**

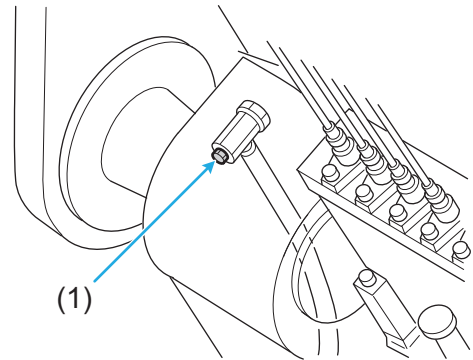

Fig. 8-95 Coolant Drain Cock on Engine Body

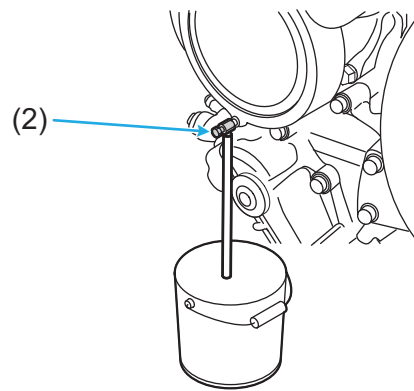

Fig. 8-96 Coolant Drain Cock on Water Pump

- 11 Remove the plastic tube connected to the coolant drain cock on the water pump in Step 7.**
- 12 Discard cleaning solution in the container in Step 6 and Step 8 properly.**

■ Cooling System - Flush

After cleaning the cooling system, flush the cooling system.

- 1 **Pour tap water through the coolant filler cap.**
- 2 **Operate the start switch of the generator ["Starting and Stopping Devices Installed during Manufacturing the Generator"](#) (→ [Page 87](#)) to start the engine.**
- 3 **Operate the engine at the rated speed for about 10 minutes.**
- 4 **Operate the stop switch of the generator ["Starting and Stopping Devices Installed during Manufacturing the Generator"](#) (→ [Page 87](#)) to turn off the engine.**
- 5 **Prepare a container for receiving drained tap water and place it under the coolant drain cock on the engine body.**

Note

- **The customer is required to prepare the container.**

- 6 **Connect a clear plastic tube to the coolant drain cock on the water pump and fix with a band.**

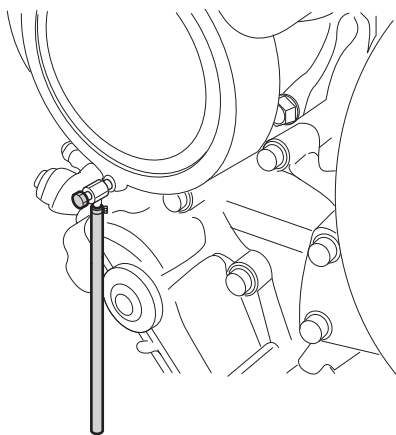

Fig. 8-97 Coolant Drain Cock on Water Pump

Note

- **Prepare a plastic tube (5 mm [0.20 in.] in diameter, approx. 1 m [39.37 in.] long) and a band.**

- 7 **Prepare a container for receiving drained tap water and place it under the coolant drain cock on the water pump.**

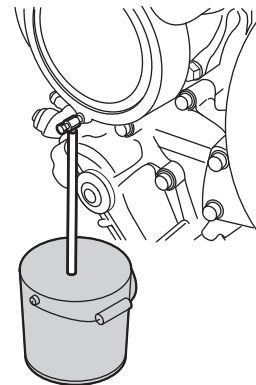

Fig. 8-98 Container to Receive Tap Water

Note

- **The customer is required to prepare the container.**

- 8 **Open the coolant drain cock (1) and (2) on the engine body and water pump.**

→The tap water poured in Step 1 will be drained.

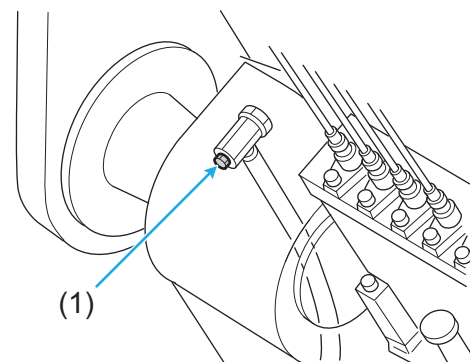

Fig. 8-99 Coolant Drain Cock on Engine Body

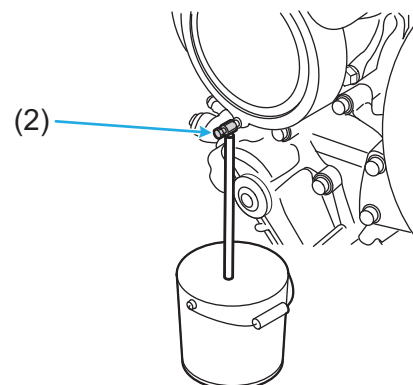

Fig. 8-100 Coolant Drain Cock on Water Pump

- 9 Close the coolant drain cock (1) and (2) on the engine body and water pump.**

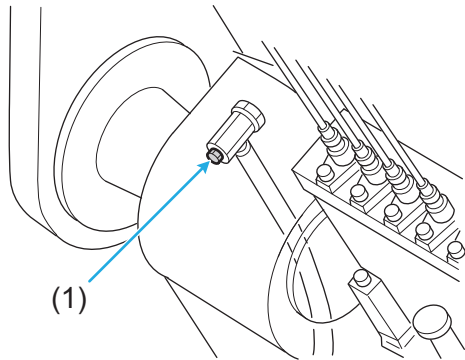

Fig. 8-101 Coolant Drain Cock on Engine Body

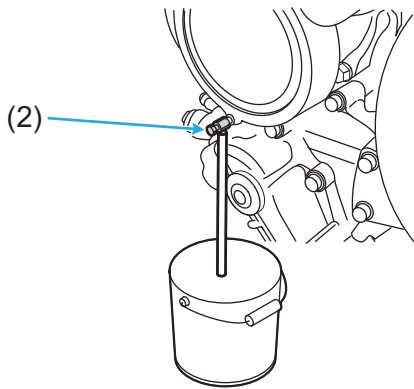

Fig. 8-102 Coolant Drain Cock on Water Pump

- 10 Discard tap water in the container in Step 5 and Step 7 properly.**
- 11 Repeat Step 1 to 10 until clean water is drained.**
- 12 Remove the plastic tube connected to the coolant drain cock on the water pump in Step 6.**
- 13 Discard water in the container or cleaning solution properly.**

■ Coolant - Refill

- 1 Close the coolant drain cock of (1) on the engine securely.**

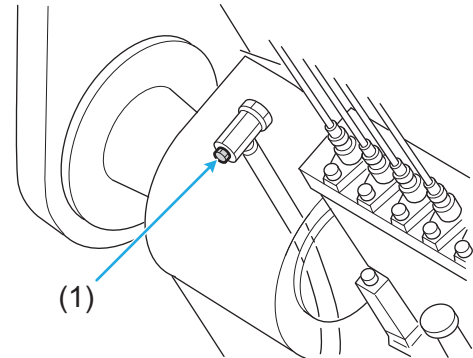

Fig. 8-103 Coolant Drain Cock on Engine Body

- 2 Close the coolant drain cock (2) on the water pump securely.**

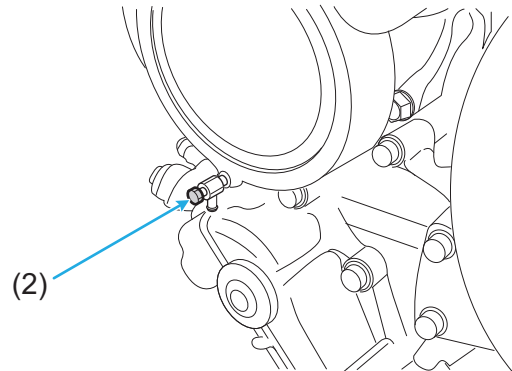

Fig. 8-104 Coolant Drain Cock on Water Pump

- 3 **Open the coolant filler cap and slowly refill the specified quantity of coolant.**

Note

- For the specified quantity of coolant, refer to **"SPECIFICATIONS - CHECK"** (→ [Page 12](#)).
- For mixing coolant, refer to **"Coolant - Mix"** (→ [Page 114](#)).
- Refill slowly to prevent air included in the coolant.

- 4 **Wait approx. 30 minutes until the coolant to circulate all parts of the coolant system, then check the coolant quantity again.**

- 5 **Check the heat exchanger and other part in the coolant system for coolant leaks.**

Note

- If a leak is found, contact your MHIET dealer **"CONTACT LIST"** (→ [Page 10](#)) to arrange the repair.

- 6 **Close the coolant filler cap properly.**

- 7 **Bleed air from the fuel system "Cooling System - Bleed Air" (→ [Page 162](#)).**

Cooling System - Bleed Air

⚠ WARNING



Bleed air sufficiently from the cooling system.

- * If air remains in the coolant, cooling performance may degrade, and seizure of the engine or piston scuffing may occur.

After changing or refilling coolant, operate the engine as follows:

- 1 **Pull the manual stop lever in the direction of stopping and hold this position, and crank the engine for approx. 10 seconds using the starter.**

→Coolant will be supplied to each part.

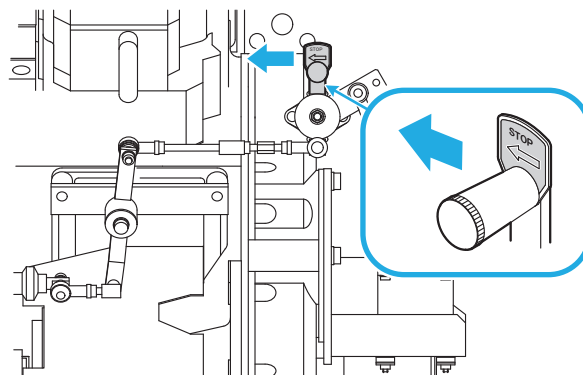

Fig. 8-105 After Coolant Change - Adjust

Note

- **The location of the manual stop lever varies depending on the specification of the engine. Refer to "Protection System - Location" (→ [Page 83](#)).**

- 2 **Pause for about 1 minute.**

- 3 **Repeat the operation of Step 1 and 2 for 2 or 3 times.**

→Coolant will reach each part.

- 4 **Slightly loosen the air vent plug at the engine coolant outlet pipe and bleed air.**

Note

- **For the location of the air vent plug, refer to such a document as the corresponding manual of the generator.**

- 5 **After checking that air has been bled, tighten the air vent plug.**

- 6 **Check the coolant level.**

- If the level is low, refill. "[Coolant - Refill](#)" (→ [Page 161](#))

Note

- **For the specified quantity of coolant, refer to "[SPECIFICATIONS - CHECK](#)" (→ [Page 12](#)).**

Radiator Fins - Check and Clean (Radiator Spec)

⚠ WARNING



When working by using compressed air, wear protective glasses.

* Not wearing or not properly wearing personal protective equipment may result in serious personal injury.

Check the radiator fins for holes and cracks.

* Otherwise, overheating, damage to the devices, or performance degradation may occur.

Cleaning Method

- 1 **Clean the radiator fins with compressed air to remove dirt, sand and engine oil.**
- 2 **If severely contaminated by oil, spray detergent on the surface of radiator fins to remove dust, sand, and oil. Choose a detergent that does not damage the radiator fin material (copper or aluminum).**

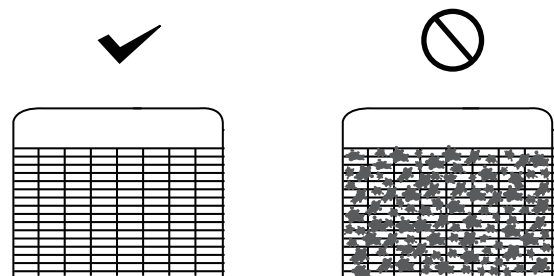

Fig. 8-106 Radiator Fin

- 3 **Clean the radiator fins from the front and back with high pressure steam. Clean in order of front side (opposite side of air flow of radiator) → back side (same side as air flow of radiator) → front side.**

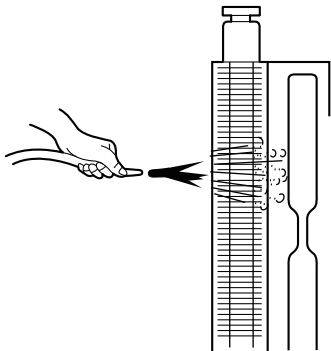

Fig. 8-107 Radiator Fin - Clean

Note

- **If you wash in reverse order, dust may be pushed into the fins, and cause damage.**
 - **Avoid excessive high pressure steam (more than 0.28 MPa {2.86 kgf/cm²} [40.61 psi]) and pressurized water as they will damage the fins.**
- 4 **Clean the surface of the radiator fins until you can see the light from the opposite side. If dust or dirt remains, the performance of the radiator will be decreased, leading to overheating.**
- 5 **Recommended cleaning intervals: clean at the time of engine oil replacement.**

Resin Fan Inspection (Specifications with Resin Fan)

Note

- **Fans supplied by our company are available in a selection of metal and resin. Please confirm in advance.**
- **The radiator may be outside the scope of our supply. For the details, refer to such a document as the specification sheet prepared by the generator manufacturer.**
- **If it is not supplied by MHIET, follow the instructions in the supplier's operation manual.**

■ Blade Inspection

⚠ WARNING



Check that there are no flaws, cracks or discoloration on the surface of blades.

- * If you operate the engine with a defective blade, the blade may break.

Check that there is no play in the blade mounting portion.

- * If there is play in the blade mounting portion, the blades may be abnormally worn.

Check that there is no looseness in the blade mounting portion.

- * If there is looseness in the blade mounting portion, the blades may break.

Since replacing a blade requires balancing, do not replace a single blade by yourself.

- * When replacing a single blade, be sure to ask MHIET dealer.

1 Check that there are no flaws, cracks or discoloration on the surface of blades.

- If there is any abnormality, please ask MHIET dealer for replacement.

2 Check that there is no play in the blade mounting portion.

- When there is play, ask MHIET dealer for replacement, as there is a risk of abnormal wear.

3 Check that there is no looseness in the blade mounting portion.

- When there is looseness, tighten the hub fixing bolt. (Tightening torque: 18 to 20 N·m {1.84 to 2.04 kgf·m} [13.28 to 14.75 lbf·ft])

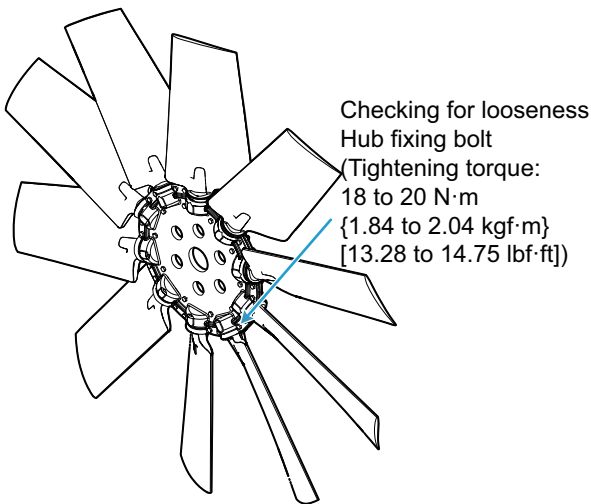

Fig. 8-108 Blade Mounting Portion

■ Blade Cleaning

⚠ WARNING



Check that there is no looseness in the blade mounting portion.

- * If there is looseness in the blade mounting portion, the blades may break.

Since replacing a blade requires balancing, do not replace a single blade by yourself.

- * If there is looseness in the blade mounting portion, the blades may break.



When replacing a single blade, be sure to ask MHIET dealer.

- * When cleaning the blades, do not use acid and alkaline solutions.

1 Use a neutral solution to clean the blade surface.

2 Wait for it to dry.

Intake and Exhaust Systems - Check

Note

- **Devices and equipment outside the scope of our supply are included in the facility. For the details, refer to such a document as the specification sheet prepared by the generator supplier.**
- **For the devices and equipment outside the scope of our supply, refer the corresponding manual of the generator and the supplier's operation manual.**

Turbocharger - Check

⚠ WARNING



Before checking the turbocharger, make sure that the engine has cooled down to normal temperature. Before checking, make sure that the compressor wheel is not rotating.

- * Otherwise, you could get burned.
- * If you are caught in a rotating compressor wheel, you will suffer laceration.



Make sure that there is no intake air leak in the piping to the compressor of the turbocharger.

- * If there is intake air leak, insufficient boost pressure could occur, which could cause deterioration in the exhaust gas properties.

⚠ CAUTION



Check that the compressor or turbine of the turbocharger is not dirty.

- * If the compressor or turbine of the turbocharger is dirty, performance degradation of the turbocharger may occur, which could cause power reduction.

Note

- **For the location of the turbocharger, refer to ["2 ENGINE - OUTLINE"](#) (→ [Page 76](#)).**
- **When the inspection requires the removal of turbocharger, contact your MHIET dealer ["CONTACT LIST"](#) (→ [Page 10](#)).**

- 1 **Remove the pipe on the inlet side.**
- 2 **Rotate the tightening nut of the compressor wheel by hand to check that it rotates smoothly.**

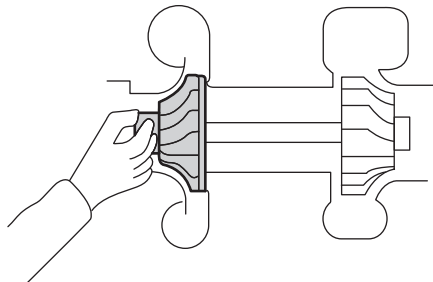

Fig. 8-109 Turbocharger - Check

Note

- **If a play or sluggish rotation is detected, contact your MHIET dealer "[CONTACT LIST](#)" (→ [Page 10](#)).**

- 3 **Check the compressor wheel fins for discoloration or damage.**

Note

- **If discoloration or damage is detected, contact your MHIET dealer "[CONTACT LIST](#)" (→ [Page 10](#)).**

Exhaust Muffler - Drain Water

⚠ WARNING



Do not touch the exhaust muffler immediately after the engine is stopped.

- Make sure that the engine is cooled down to the normal temperature.
- * Otherwise, you could get burned.

Be sure to drain the exhaust muffler.

Note

- **The exhaust muffler is outside the scope of our supply. For the details, refer to the corresponding manual of the generator and the supplier's operation manual.**

Pre-cleaner - Check and Service

⚠ WARNING



Do not check, maintain or remove the pre-cleaner during operation.

- * Otherwise, dust or other foreign particles may enter the engine, which could accelerate wear of the parts or cause damage to the devices including the turbocharger.



Take care that parts will not fall down and get caught in the fuel control link.

- * If parts are caught in the fuel control rack, the engine will become out of control.

Check the pre-cleaner for clogging and clean it.

■ Pre-cleaner - Check for Clogging

⚠ WARNING



Make sure that the pre-cleaner is free from clogging.

- * Insufficient intake air could result in loss of power, incomplete combustion, exhaust gas temperature rise, and overspeed of the turbocharger.

Check the pre-cleaner for clogging.

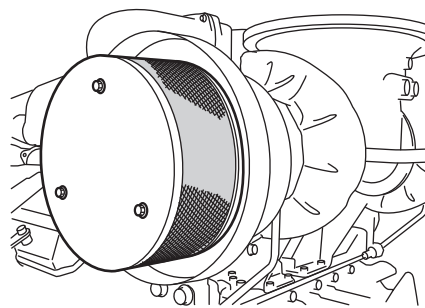

Fig. 8-110 Pre-cleaner - Check for Clogging

■ Pre-cleaner - Clean

The following is a general procedure.

- 1 Release the hook-and-loop fastener (1), and take the pre-cleaner (2) from the silencer.**

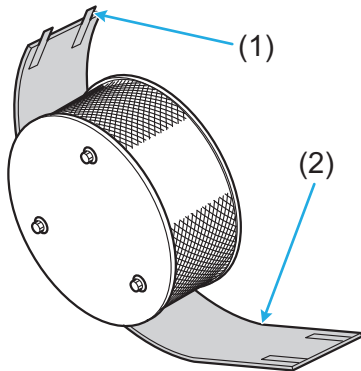

Fig. 8-111 Pre-cleaner - Remove

- 2 Wash the pre-cleaner by hand using a neutral detergent.**

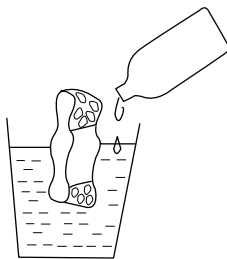

Fig. 8-112 Pre-cleaner - Clean 1

- 3 Rinse the pre-cleaner with fresh water.**

- Discard the rinsed water properly.

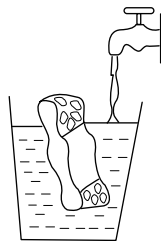

Fig. 8-113 Pre-cleaner - Clean 2

- 4 Dry the pre-cleaner naturally and sufficiently.**

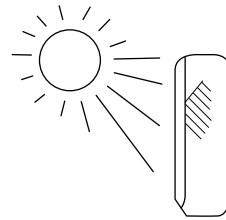

Fig. 8-114 Pre-cleaner - Clean 3

- 5 Check the pre-cleaner for tears.**

→If a tear or other damage is found, replace the pre-cleaner with a new one.

- 6 Install the pre-cleaner (2) on the silencer.**

- Check that the hook-and-loop fastener (1) is retained firmly so that the pre-cleaner will not drop off.

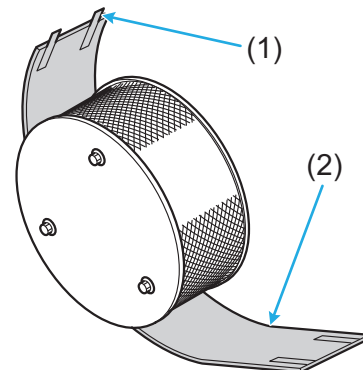

Fig. 8-115 Pre-cleaner - Install

Air Cleaner - Check and Service

Check the air cleaner for clogging and clean the air cleaner element.

Note

- **The air cleaner may be outside the scope of our supply. For the details, refer to such a document as the specification sheet prepared by the generator manufacturer.**
- **If it is not supplied by MHIET, follow the instructions in the supplier's operation manual.**

■ Air Cleaner - Check for Clogging

WARNING



Make sure that the air cleaner is free from clogging.

- * Insufficient intake air could result in loss of power, incomplete combustion, exhaust gas temperature rise, and overspeed of the turbocharger.

Check the air cleaner for clogging.

■ Air Cleaner Element - Clean

Clean the air cleaner element.

- If necessary, replace the air cleaner element with a new one.

Electrical System - Check

Battery - Check

WARNING



Do not short the battery terminals.

- * Otherwise, sparks could occur and cause a fire or an explosion.

Do not touch battery terminal with a wet hand.

- * There are possibilities to get an electric shock.



When checking and servicing the battery, wear suitable personal protective equipment such as protective eyeglasses, rubber gloves, working clothes with long sleeves and long trousers.

- * If battery fluid comes into contact with your eyes or skin, it may result in sight loss or burns.

Note

- **The battery is outside the scope of our supply. For the details, refer to the corresponding manual of the generator and the supplier's operation manual.**

1 Check the battery fluid level.

- Refill the battery fluid, if necessary.

2 Check the battery fluid specific gravity.

- Charge the battery, if necessary.

Starter - Check (Self Starter Motor Starting)

⚠ CAUTION



Check that there is no damage to the pinion gear of the starter.

* Otherwise, a spark or damage to the devices could occur.

Note

- For the location of the starter, refer to **"2 ENGINE - OUTLINE"** (→ [Page 76](#)).

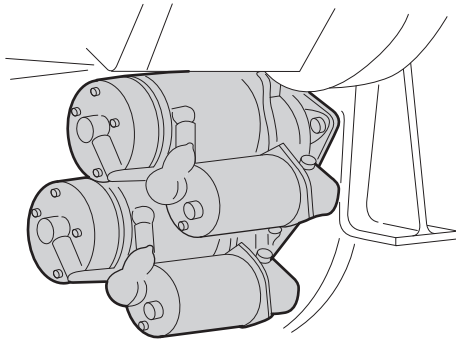

Fig. 8-116 Starter - Check
(Self Starter Motor Starting)

Visually check the starter.

- Check for damage.

Note

- **If the starter is damaged or defective, contact your MHIET dealer **"CONTACT LIST"** (→ [Page 10](#)).**

Alternator - Check

⚠ CAUTION



Do not touch the rotating part of the alternator.

* Otherwise, you may get caught in the rotating part and suffer an injury or damage to the devices could occur.

Note

- For the location of the alternator, refer to **"2 ENGINE - OUTLINE"** (→ [Page 76](#)).

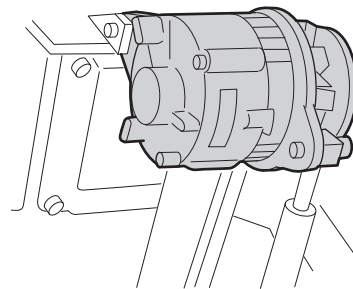

Fig. 8-117 Alternator - Check

- 1 **Check the alternator for damage.**
- 2 **Remove the belt.**
- 3 **Rotate the pulley by hand to check the smooth rotation.**

Note

- **If the alternator is defective, contact your MHIET dealer **"CONTACT LIST"** (→ [Page 10](#)).**

Air Direct Admission Starting, Air Motor Starting - Check

Note

- **Devices and equipment outside the scope of our supply are included in the facility. For the details, refer to such a document as the specification sheet prepared by the generator supplier.**
- **For the devices and equipment outside the scope of our supply, refer the corresponding manual of the generator and the supplier's operation manual.**

Air Strainer - Drain Water and Clean

⚠ WARNING



When working by using compressed air, wear protective glasses.

* Not wearing or not properly wearing personal protective equipment may result in serious personal injury.

⚠ CAUTION



Before draining or cleaning the starting air strainer, bleed air completely. In addition, check the pressure reduction with the pressure gauge.

* If high pressure air remains in the pipe, the drain valve may blow off, which could cause personal injury or damage to the devices.

Note

- **The starting air strainer may be outside the scope of our supply. For the details, refer to such a document as the specification sheet prepared by the generator manufacturer.**
- **If it is not supplied by MHIET, follow the instructions in the supplier's operation manual.**

- 1 Close the main valve of the starting air tank.**
→The air supply stops.
- 2 While cranking the engine lightly, bleed air remaining in the engine and the starting air system.**

- 3 Prepare a container for receiving drained water and place it under the drain plug of the air strainer.**

Note

- **The customer is required to prepare the container.**

- 4 Remove the drain plug on the air strainer.**
→Water accumulated in the air strainer is drained.

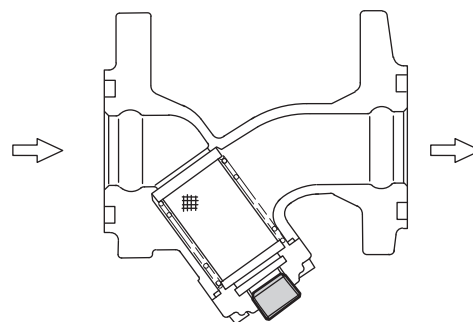

Fig. 8-118 Drain Plug - Remove

- 5 Remove the cap (1) and remove the filter (2) from the cap.**

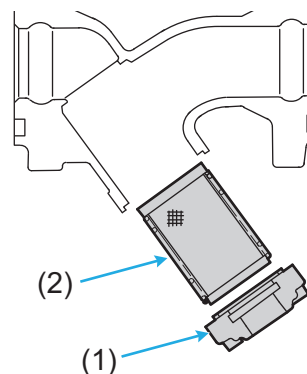

Fig. 8-119 Cap and Filter - Remove

- 6 Clean the filter with diesel fuel, then blow compressed air to dry.**
- 7 Reassemble the starting air strainer as it was.**
- 8 Open the main valve of starting air tank slowly.**
→This allows air to be supplied.

Starting Air Tank - Check and Service (Air Direct Admission Starting, Air Motor Starting)

WARNING



Be sure to drain water from the starting air tank.

* Otherwise, water could enter the cylinders when starting the engine.

Make sure that the safety valve on the starting air tank is not malfunctioning.

* If the safety valve is out of order, improper operation could occur, which could result in explosion of the starting air tank.

CAUTION



Be sure to drain water from the starting air tank.

* Otherwise, water could enter the air motor when starting the engine.

Drain the starting air tank and check the operation of the safety valve.

Note

- **The starting air tank may be outside the scope of our supply. For the details, refer to such a document as the specification sheet prepared by the generator manufacturer.**
- **If it is not supplied by MHIET, follow the instructions in the supplier's operation manual.**
- **If the safety valve is defective, contact your MHIET dealer ["CONTACT LIST"](#) (→ [Page 10](#)).**

Starting Air Motor - Check (Air Motor Starting)

- 1 **Check the starting air motor for damage.**
- 2 **If the air motor is dusty, blow dry compressed air to the starting air motor to remove the dust.**

9 LONG-TERM STORAGE

This chapter describes the long-term storage procedure.

Storing Engine in Inoperable Condition

If you will store this engine in inoperable condition for 3 months or longer (1 year at longest), follow the procedure shown below.

Note

- **Devices and equipment outside the scope of our supply are included in the facility. For the details, refer to such a document as the specifications sheet prepared by the generator manufacturer.**
- **For the devices and equipment outside the scope of our supply, refer the corresponding manual of the generator and the supplier's operation manual.**

Storage - Prepare (Rust-preventive Measure)

⚠ WARNING



Keep away from fire, when working with flammable substances such as volatile corrosion inhibitor or rust preventive oil.

* They may cause a fire.

Keep away from fire, when working with flammable substances such as grease.

* They may cause a fire.

* When handling grease, obey the manufacturer's SDS.



If the engine is stored for 3 month or longer (up to 1 year), apply rust-preventive measure properly.

* Otherwise, the internal engine parts and/or sliding parts may be rusted, which could cause damage to the devices.

* Follow the storage procedure described in this Operation & Maintenance Manual.

⚠ WARNING



Use volatile corrosion inhibitor and rust preventive oil recommended by us.

* If a product other than the recommendation is used, the internal engine parts may be rusted due to insufficient anti-rust effect.

Use new (immediately after opened) desiccant.

* If you use a product which has been unused for a long time since its package was opened, moisture absorbency may be weakened, and may cause the internal engine parts and/or sliding parts to rust.

After stopping the engine, spray volatile corrosion inhibitor while cranking the engine for at least 2 times.

* Otherwise, anti-corrosive agent may accumulate and harden on the piston, which could block turning.

⚠ CAUTION



When handling volatile corrosion inhibitor or rust preventive oil, wear personal protective equipment such as protective mask or protective glasses, and obey the manufacturer's SDS.

* If such products are breathed in or comes in contact with the skin, serious personal injury may occur.

When working with grease, wear suitable personal protective equipment such as protective eyeglasses, rubber gloves, working clothes with long sleeves and long trousers.

* If grease comes into contact with your eyes, it will cause irritations.

* When handling grease, obey the manufacturer's SDS.

Before storing this engine, prepare as follows.

■ Lubrication System

Change engine oil ["Engine Oil - Change"](#) (→ [Page 147](#)).

■ Fuel System

1 Prepare a fuel mixture containing 50% rust-preventive fuel.

- Recommended product:
ANTIRUST TERAMI LN (ENEOS Corporation)

Note

- **The quantity varies depending on the pipings and others. Identify the required quantity previously.**
- 2 **Operate the start switch of the generator ["Starting and Stopping Devices Installed during Manufacturing the Generator"](#) (→ [Page 87](#)) to start the engine.**
 - 3 **Operate the engine at an idle speed until the fuel remained in the engine is completely consumed.**
 - 4 **After that the fuel remained in the engine is completely consumed, refill the fuel mixture into the fuel tank, or switch the fuel pipes to feed the fuel mixture into the engine.**
 - 5 **Operate the start switch of the generator ["Starting and Stopping Devices Installed during Manufacturing the Generator"](#) (→ [Page 87](#)) to start the engine.**
 - 6 **Close the fuel valve.**

■ Air Intake System

Spray volatile corrosion inhibitor while cranking the engine for 2 times or more.

- Recommended product:
V.C.I. Volatile Corrosion Inhibitor DIANA ND (Mitsubishi Gas Chemical Trading, Inc.)

■ Machined Area

Apply corrosion inhibitor to the machined and exposed area (around the flywheel, and others) sufficiently.

- Recommended product:
ANTIRUST TERAMI SC (ENEOS Corporation)

■ Others

- 1 **Seal the air inlet, exhaust outlet, breather and other openings with adhesive cloth tape.**
- 2 **Loosen the tension of each belt on the crank pulley or alternator. ["Belt Tension \(Alternator\) - Adjust"](#) (→ [Page 129](#))**
- 3 **Wind adhesive cloth tape around the terminals of the starter and alternator.**

Storage

- 1 **Disconnect the cables from the battery terminals.**
- 2 **Place a cover over the entire engine and put in desiccant.**

Note

- Store the engine in a well-ventilated and dried indoor area.
- Post a sign noted as "Fuel tank must be filled" on the fuel inlet pipe, etc. for the first startup after storage.

- 3 **Charge the battery disconnected in Step 1.**
- 4 **After charging, clean around the battery terminals, and apply grease lightly.**

Note

- Store the battery in a dry cool indoor area.

Maintenance during Storage

⚠ WARNING



Do not short the battery terminals.

* Otherwise, sparks could occur and cause a fire or an explosion.



When checking and servicing the battery, wear suitable personal protective equipment such as protective eyeglasses, rubber gloves, working clothes with long sleeves and long trousers.

* If battery fluid comes into contact with your eyes or skin, it may result in sight loss or burns.

Check battery fluid level, and then charge the battery once a month.

Restart after Storing

When restarting the engine after storing, follow the next procedure:

■ Preparation

- 1 **Remove the cover that has been placed over the entire engine.**
- 2 **Remove the adhesive cloth tape from around the terminals of the starter and alternator.**
- 3 **Adjust the tension of each belt on the crank pulley or alternator. ["Belt Tension \(Alternator\) - Adjust"](#) (→ [Page 129](#))**
- 4 **Remove the adhesive cloth tape from around the air inlet, exhaust outlet, breather and other openings.**
- 5 **Connect each piping of the fuel system and others.**
- 6 **Connect a well-charged battery stored.**
- 7 **Perform the pre-operation check. ["Pre-operation Check"](#) (→ [Page 92](#))**
- 8 **Remove the rocker cover from all the cylinder heads.**
 - Tool: Wrench

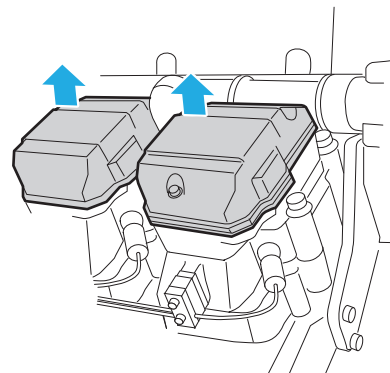

Fig. 9-1 Rocker Cover - Remove

9 Apply engine oil on the valve mechanisms of all the cylinder heads.

- Tool: Oiler, oil jug, and others.

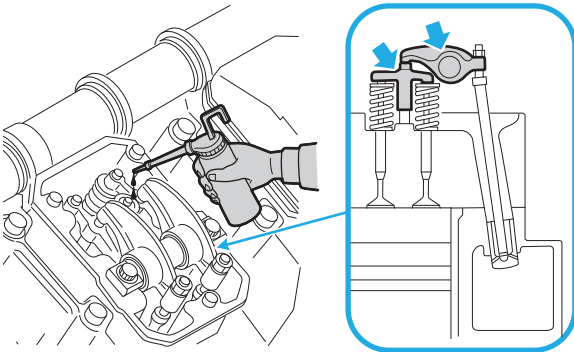

Fig. 9-2 Engine Oil - Apply (Valve Mechanism)

10 Install the rocker covers onto all the cylinder heads.

- Tool: Wrench

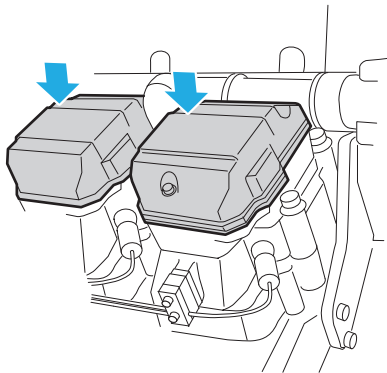

Fig. 9-3 Rocker Cover - Install

Restart

- 1 Pull the manual stop lever in the direction of stopping and hold this position, and crank the engine for approx. 10 seconds using the starter.

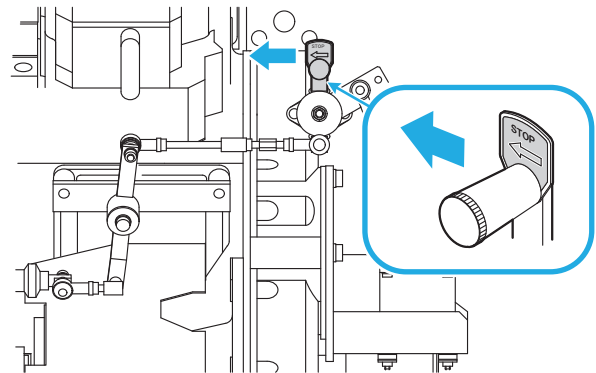

Fig. 9-4 Restart after Storing

Note

- The location of the manual stop lever varies depending on the specification of the engine. Refer to "[Protection System - Location](#)" (→ [Page 83](#)).

- 2 Pause for about 1 minute.
- 3 Repeat the operation of Step 1 and 2 for 2 or 3 times.
- 4 After starting the engine, make sure that the engine oil pressure rises with a pressure gauge.
- 5 Conduct a warm-up operation for a sufficient duration to fully lubricate all the components.
- 6 Operate the engine under load.

Storing Engine in Operable Condition

Perform maintenance operation "[Maintenance Operation](#)" (→ [Page 103](#)) once a month.

10 TRANSPORTATION

This chapter describes the transporting procedure of this engine.

Precautions on Transportation

⚠ WARNING

! When transporting the engine on a truck, consider the engine weight, width and height to ensure safety. Abide by road traffic law, road vehicles act, vehicle restriction ordinance and other pertinent laws.

- * Operation of the truck disregarding the laws and regulations may cause traffic accident or damage to the devices.

Be extremely careful when transporting the engine on rough roads.

- * Otherwise, a traffic accident such as rollover or damage to the devices may occur.

Obey the laws or regulations of each country where this engine is used.

Engine - Lift

⚠ WARNING

⊘ When lifting up the engine, do not allow the operators to stay under the engine.

- * Otherwise, if the wire breaks, the engine may fall down, which could cause serious personal injury.

! The engine must be lifted only by an operator who is qualified for a crane and slinging works and also well skilled.

- * Otherwise, the engine may fall by an operation error, which could cause serious personal injury or damage to the devices.

⚠ WARNING

! To lift the engine, take the mass of the engine and that of water remained in the engine into account, and use wire ropes, shackles, and slings which are strong enough to support the weight.

- * Otherwise, the engine may slip down, which could cause serious personnel injury or damage to the devices.
- * Check the contract specifications for engine dry mass.

Use sling/hoisting tools in accordance with their instruction manual.

- * Otherwise, the engine may slip down, which could cause serious personnel injury or damage to the devices.

Use the hangers of the engine only for lifting the engine unit.

- * If you use them when the engine is assembled with the generator and additional devices, the hanger may not be able to endure the mass and may break. If the engine falls, serious personnel injury or damage to the devices will occur.

Before lifting the engine, drain fuel, engine oil and coolant.

- * Otherwise, the hanger may not be able to endure the mass and break. If the engine falls, serious personnel injury or damage to the devices may occur.

Lift the slings while keeping the angle formed by the slings attached to the hangers within 60°.

- * If the angle is too large, excessive weight will be imposed on the hanger, which could cause damage to the hanger.

- When using the crane, the person who has obtained the crane operator's license and also have a certificate of the skill training course for slinging operation must operate the crane.
- Also when using a mobile crane, the person must have a mobile crane operator's license.
- Obey the corresponding laws and regulations.

The above-mentioned description is based on the premise that this engine is used in Japan. Obey the laws or regulations of each country where this engine is actually used.

Note

- **Devices and equipment outside the scope of our supply are included in the facility.
For the details, refer to such a document as the specifications sheet prepared by the generator manufacturer.**
- **For the devices and equipment outside the scope of our supply, refer the corresponding manual of the generator and the supplier's operation manual.**

- 1 Drain fuel, engine oil and coolant from the engine.**
- 2 Disconnect the wiring and pipings from the engine.**
- 3 Remove pipe covers and insulators located near the hangers.**
- 4 Hook the slings on the hangers.**

Note

- **For the location of the hangers, refer to ["ENGINE - OUTLINE" \(→ Page 76\)](#).**
- 5 Release the lockings between the engine and the common bed.**
 - 6 Lift up the engine by using a crane while checking the balance.**
 - Consider the engine's center of gravity to lift the engine.
 - 7 Slowly lower the engine on to a rack for transport, and so on.**
 - 8 Fix the engine to the rack for transport, and so on.**

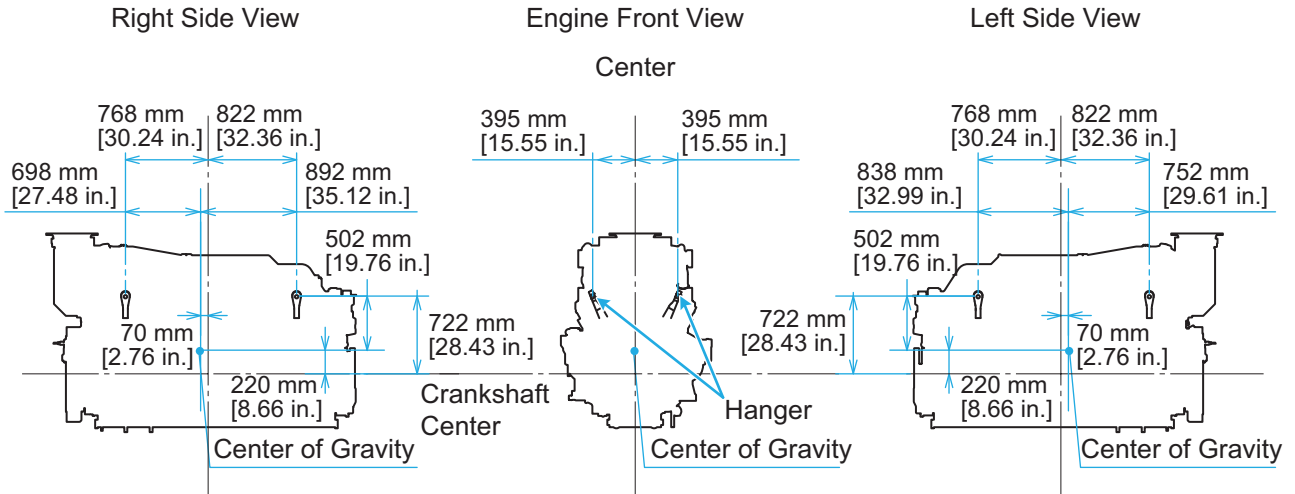



Fig. 10-1 Engine's Center of Gravity

11 TROUBLESHOOTING

This chapter describes the troubleshooting and action procedures.

Precautions on Troubleshooting

DANGER

 **Before inspecting and maintaining the engine, read this Operation & Maintenance Manual thoroughly to understand the construction and the required work to service the corresponding part. In addition, conduct the work after fully studying the procedure.**

- * In case of conducting the work without studying enough, an accident or damage due to wrong installation, or deterioration in the exhaust gas properties may occur.

WARNING

 **Do not take actions for items indicated as "Contact your MHIET dealer" in the measure column in the Scheduled Maintenance.**

- * Otherwise, serious accident, environmental pollution or damage to the devices may occur. Be sure to contact your MHIET dealer.

Do not disconnect the pipes immediately after the engine is stopped.

- * Otherwise, you could get burned by hot engine oil or coolant splashing out.

 **When lifting a part or tool, check its weight and lift it slowly.**

- * If you lift it carelessly, you may hurt your back or get injured by dropping the part.

Make sure that dripped oil, parts, tools or other things are not left on the floor around the engine. Always maintain cleanliness and tidiness.

- * Otherwise, a tumbling accident may occur.
- * Wear proper personal protective equipment for the work.

WARNING

 **Make sure that the tools to be used are not damaged.**

- * Using a damaged tool or a wrong-size tool may cause personal injury or damage to the devices.

Check and calibrate measurement equipment periodically.

- * Using uncalibrated measurement equipment may cause damage to the devices or performance degradation of them.

Watch your step during inspection and maintenance work.

- * Otherwise, a tumbling accident or a falling accident may occur while working on the floor panel or other high positions.
- * The floor could be extremely slippery due to spilt oil. Thoroughly wipe off oil on the floor and the sole of your shoes.
- * Install a stable scaffold as required.

Before maintaining electrical components, place the battery switch to the OFF position or disconnect the battery negative (-) terminal.

- * Electric shock could result when electricity flows through the circuit.

Cover the disconnected pipes or joints and their openings properly so that dusts or other foreign objects will not enter into them.

- * Otherwise, the devices could be damaged.

■ Remedies to Faults

Except for refilling fuel, engine oil, and coolant, remedies to faults will require special equipment or involves dangerous work.

Contact your MHIET dealer "[CONTACT LIST](#)" ([→ Page 10](#)).

■ Before Taking Actions

Before taking any remedies, inspect possible causes of the fault and try to find out if the same fault has occurred in the past.

In addition, closely investigate the parts that may be causing the problem.

When disassembly of any part of the engine is needed, pay close attention to the disassembly sequence so that you can effectively assemble later.

■ Cautions Against Contamination

Wear of parts are very often caused by aged deterioration or impurities such as dust.

When disassembling any part of the engine, take measures to prevent dust and foreign materials from entering.

■ Parts - Handling

Handle parts carefully.

When replacing, use genuine parts.

■ Safety Working Practices

Use correct tools, and perform work with the utmost care.

If you misjudge the weight, you may damage the part by dropping it, or get injured.

How to Troubleshoot

In general, problems can be divided into 3 types:

- (a) Machine-related problems
- (b) Electricity-related problems
- (c) Operation-related problems

If any problem occurs, it is necessary to precisely determine which of the three types applies.

Perform the troubleshooting by using the following steps:

- 1 Check the following items.**
 - Under what conditions was the engine running?
 - What operation was performed?
 - Any external factors?
- 2 Refer to the next "Troubleshooting" and determine the cause.**
- 3 Take the measures according to the Remedies.**

Note

- **If the problem is not solved after the measures have been taken, or if there is any uncertainty about the cause or remedies of the problem, contact your MHIET dealer "[CONTACT LIST](#)" ([→ Page 10](#)).**

Troubleshooting

Note

- **Devices and equipment outside the scope of our supply are included in the facility. For the details, refer to such a document as the specifications sheet prepared by the generator manufacturer.**
- **For the devices and equipment outside the scope of our supply, refer to the corresponding manual of the generator and the supplier's operation manual.**

Starter Does Not Crank or Cranks Slowly, Resulting in Starting Failure

Table 11-1 Starter Does Not Crank or Cranks Slowly, Resulting in Starting Failure

Problem	Cause		Remedies	Reference Page
Starter Does Not Crank or Cranks Slowly, Resulting in Starting Failure	Electrical System	Faulty wire connection, insufficient capacity	<ul style="list-style-type: none"> • Check fuse. • Check wiring connection between battery, starter, and starter switch. 	-
		Battery charge fault	• Alternator -Check	169
			• Check and adjust the belt.	127 129
		Capacity degradation of the battery	<ul style="list-style-type: none"> • Check the level and specific gravity of the electrolyte • Charge battery. • Replace battery. 	168
	Faulty starter or faulty safety relay	• Contact your MHIET dealer.	10	
	Lubrication System	Oil viscosity too high	• Change with appropriate engine oil.	110 147
		Excessive oil level	<ul style="list-style-type: none"> • Engine oil level - Check • Check lubrication system. 	149
Engine Body	Wear or lock of sliding parts	• Contact your MHIET dealer.	10	

Starter Cranks, but Engine Does Not Start

Table 11-2 Starter Cranks, but Engine Does Not Start

Problem	Cause	Remedies	Reference Page	
Starter Cranks, but Engine Does Not Start	Fuel System	Run out of fuel, blocked pipe	<ul style="list-style-type: none"> • Check fuel tank, add fuel and bleed air. • Check fuel pipes and valves. 	134
		Improper fuel properties	<ul style="list-style-type: none"> • Change with appropriate fuel. • Remove dust, water and impurities. 	104 134
		Fuel leaks from low pressure fuel line	<ul style="list-style-type: none"> • Check defects of low pressure fuel line and retighten, if necessary. 	144
		Fuel leaks from high pressure fuel injection pipe	<ul style="list-style-type: none"> • Check defects of high pressure fuel injection pipe 	144
			<ul style="list-style-type: none"> • Contact your MHIET dealer. 	10
		Clogged fuel filter	<ul style="list-style-type: none"> • Check and replace fuel filter. • Gauze filter - Clean • Change to fuel suitable for the ambient temperature. 	140 139 104
		Fuel feed pump malfunction	<ul style="list-style-type: none"> • Contact your MHIET dealer. 	10
		Fuel injection pump malfunction	<ul style="list-style-type: none"> • Check fuel injection pump rack stroke. 	-
	<ul style="list-style-type: none"> • Contact your MHIET dealer. 		10	
	Fuel injection nozzle malfunction	<ul style="list-style-type: none"> • Contact your MHIET dealer. 	10	
	Air Intake System	Insufficient amount of intake air	<ul style="list-style-type: none"> • Turbocharger - Check 	165
		Poor ventilation	<ul style="list-style-type: none"> • Clean, check and replace air cleaner element. • Clean, check and replace pre-cleaner. 	168
	Control System	Governor malfunction	<ul style="list-style-type: none"> • Fuel control link - Check 	142
<ul style="list-style-type: none"> • Contact your MHIET dealer. 			10	
Engine Body	Compression pressure drop	<ul style="list-style-type: none"> • Contact your MHIET dealer. 	10	
Additional Equipment	Water heater switch "OFF"	<ul style="list-style-type: none"> • Check water heater switch 	-	

Output Shortage

Table 11-3 Output Shortage (1/2)

Problem	Cause	Remedies	Reference Page	
Output Shortage	Fuel System	Improper fuel properties	<ul style="list-style-type: none"> • Change with appropriate fuel. 	104
		Faulty fuel injection timing	<ul style="list-style-type: none"> • Check fuel injection pump drive coupling. 	-
			<ul style="list-style-type: none"> • Contact your MHIET dealer. 	10
		Improper maximum injection volume	<ul style="list-style-type: none"> • Fuel system - Bleed air 	134
			<ul style="list-style-type: none"> • Check fuel injection pump rack stroke. • Check the balance between left and right banks. 	-
			<ul style="list-style-type: none"> • Contact your MHIET dealer. 	10
	Clogged fuel filter	<ul style="list-style-type: none"> • Check and replace fuel filter. • Gauze filter - Clean • Change to fuel suitable for the ambient temperature. 	140 139 104	
		Fuel feed pump malfunction	<ul style="list-style-type: none"> • Contact your MHIET dealer. 	10
	Cooling System	Overheating	<ul style="list-style-type: none"> • Refer to the items of overheating. 	190
		Overcooling	<ul style="list-style-type: none"> • Check fan and heat exchanger. • Check control system. 	-
			<ul style="list-style-type: none"> • Contact your MHIET dealer. 	10
	Inlet and Exhaust Systems	Insufficient amount of intake air	<ul style="list-style-type: none"> • Turbocharger - Check • Clean, check and replace pre-cleaner. • Clean, check and replace air cleaner element. • Check intake air pressure and leakage of intake air. • Check intake air temperature and ventilation device. 	165 166 168
			<ul style="list-style-type: none"> • Contact your MHIET dealer. 	10
Increase of exhaust resistance			<ul style="list-style-type: none"> • Turbocharger - Check • Check exhaust pipes, muffler and silencer. 	165
			<ul style="list-style-type: none"> • Contact your MHIET dealer. 	10

Table 11-4 Output Shortage (2/2)

Problem	Cause		Remedies	Reference Page
Output Shortage	Control System	Faulty governor control	• Contact your MHIET dealer.	10
	Engine Body	Compression pressure drop	• Contact your MHIET dealer.	10
		Faulty valve timing		
		Wear of sliding parts		
Additional Equipment	Water heater switch "OFF"	• Check water heater switch	-	

Exhaust Smoke is White or Blue

Table 11-5 Exhaust Smoke is White or Blue

Problem	Cause	Remedies	Reference Page	
Exhaust Smoke is White or Blue	Fuel System	Improper fuel properties	<ul style="list-style-type: none"> • Check cetane index. • Change with appropriate fuel. 	107 104
		Faulty fuel injection timing Not good	• Check fuel injection pump drive coupling.	-
			• Contact your MHIET dealer.	10
		Uneven fuel injection volume	• Check ignition sound, exhaust temperature and the balance between left and right banks.	-
	• Contact your MHIET dealer.		10	
	Fuel injection nozzle malfunction	• Contact your MHIET dealer.	10	
	Lubrication System	Combustion of engine oil	• Engine oil level - Check	149
			• Check lubrication system.	
	Cooling System	Overcooling	• Check heat exchanger.	-
			• Check control system.	
Engine Body	Faulty valve timing Compression pressure drop	• Check thermostat.		
		• Contact your MHIET dealer.	10	
Additional Equipment	Water heater switch "OFF"	• Check water heater switch.	-	

Exhaust Smoke is Black or Dark Grey

Table 11-6 Exhaust Smoke is Black or Dark Grey (1/2)

Problem	Cause	Remedies	Reference Page	
Exhaust Smoke is Black or Dark Grey	Fuel System	Improper fuel properties	<ul style="list-style-type: none"> • Change with appropriate fuel. 	104
		Fuel feed pump malfunction	<ul style="list-style-type: none"> • Contact your MHIET dealer. 	10
		Fuel injection pump malfunction		
		Fuel injection nozzle malfunction		
		Faulty fuel injection timing	<ul style="list-style-type: none"> • Check fuel injection pump drive coupling. • Contact your MHIET dealer. 	- 10
			Uneven fuel injection volume	<ul style="list-style-type: none"> • Check ignition sound, exhaust temperature and the balance between left and right banks. • Contact your MHIET dealer.
	Lubrication System	Combustion of engine oil	<ul style="list-style-type: none"> • Check engine oil properties. • Engine oil level - Check 	149
			<ul style="list-style-type: none"> • Contact your MHIET dealer. 	10
	Inlet and Exhaust Systems	Insufficient amount of intake air	<ul style="list-style-type: none"> • Turbocharger - Check • Clean, check and replace pre-cleaner. • Clean, check and replace air cleaner element. • Check intake air pressure and leakage of intake air. • Check intake air temperature and ventilation system. 	165 166 168
			<ul style="list-style-type: none"> • Contact your MHIET dealer. 	10
			Increase of exhaust resistance	<ul style="list-style-type: none"> • Turbocharger - Check • Check exhaust pipes, muffler and silencer.
		<ul style="list-style-type: none"> • Contact your MHIET dealer. 		10

Table 11-7 Exhaust Smoke is Black or Dark Grey (2/2)

Problem	Cause		Remedies	Reference Page
Exhaust Smoke is Black or Dark Grey	Control System	Excessive load	• Check control system and governor controller.	-
			• Check boost compensator.	
	Engine Body	Compression pressure drop	• Contact your MHIET dealer.	10
			Faulty valve timing	• Contact your MHIET dealer.
Wear of sliding parts				

Excessive Fuel Consumption

Table 11-8 Excessive Fuel Consumption

Problem	Cause	Remedies	Reference Page	
Excessive Fuel Consumption	Fuel System	Fuel injection nozzle malfunction	<ul style="list-style-type: none"> Contact your MHIET dealer. 	10
		Faulty fuel injection timing	<ul style="list-style-type: none"> Check fuel injection pump drive coupling. 	-
			<ul style="list-style-type: none"> Contact your MHIET dealer. 	10
		Improper fuel properties	<ul style="list-style-type: none"> Change with appropriate fuel. 	104
		Fuel leaks from low pressure fuel line	<ul style="list-style-type: none"> Check defects of low pressure fuel line and retighten, if necessary. 	144
	Fuel leaks from high pressure fuel injection pipe	<ul style="list-style-type: none"> Check defects of high pressure fuel injection pipe 	144	
		<ul style="list-style-type: none"> Contact your MHIET dealer. 	10	
	Cooling System	Overcooling	<ul style="list-style-type: none"> Check fan and heat exchanger. Check control system. Check thermostat. 	-
			<ul style="list-style-type: none"> Contact your MHIET dealer. 	10
	Inlet and Exhaust Systems	Insufficient amount of intake air	<ul style="list-style-type: none"> Turbocharger - Check 	165
			<ul style="list-style-type: none"> Clean, check and replace pre-cleaner. 	166
			<ul style="list-style-type: none"> Clean, check and replace air cleaner element. Check intake air pressure and leakage of intake air. Check intake air temperature and ventilation system. 	168
		<ul style="list-style-type: none"> Contact your MHIET dealer. 	10	
	Increase of exhaust resistance	<ul style="list-style-type: none"> Turbocharger - Check 	165	
		<ul style="list-style-type: none"> Check exhaust pipes, muffler and silencer. 	166	
<ul style="list-style-type: none"> Contact your MHIET dealer. 	10			
Engine Body	Compression pressure drop	<ul style="list-style-type: none"> Contact your MHIET dealer. 	10	
	Faulty valve timing			
	Wear of sliding parts			

Excessive Engine Oil Consumption

Table 11-9 Excessive Engine Oil Consumption

Problem	Cause		Remedies	Reference Page
Excessive Engine Oil Consumption	Fuel System	Faulty fuel injection timing	• Check fuel injection pump drive coupling.	-
			• Contact your MHIET dealer.	10
	Lubrication System	Oil leaking on engine outside	• Check engine oil leaks.	-
			• Contact your MHIET dealer.	10
		Faulty engine oil property (viscosity)	• Analyze engine oil properties	-
			• Change with the engine oil of proper viscosity.	199
	Excessive engine oil temperature	• Engine oil level - Check	149	
		• Check lubrication system. • Check oil cooler and oil thermostat.		
	Cooling System	Overheating	• Contact your MHIET dealer.	10
			• Refer to the items of overheating.	190
	Inlet and Exhaust Systems	Oil entry to the air supply chamber	• Check oil leakage to the turbocharger.	-
			• Contact your MHIET dealer.	10
Worn parts in valve operating system		• Contact your MHIET dealer.	10	
Control System	Excessive load	• Check control system and governor controller.	-	
		• Contact your MHIET dealer.	10	
Engine Body	Wear of sliding parts	• Contact your MHIET dealer.	10	

Overheating

Table 11-10 Overheating

Problem	Cause		Remedies	Reference Page
Overheating	Cooling System	Low coolant level	<ul style="list-style-type: none"> • Check coolant leakage. • Coolant level - Check 	-
		Excessive LLC concentration	<ul style="list-style-type: none"> • Check LLC concentration 	114
		Water pump malfunction	<ul style="list-style-type: none"> • Contact your MHIET dealer. 	10
		Thermostat malfunction	<ul style="list-style-type: none"> • Contact your MHIET dealer. 	10
		Heat exchanger malfunction	<ul style="list-style-type: none"> • Check and clean heat exchanger. 	-
	Control System	Excessive load	<ul style="list-style-type: none"> • Check fuel injection pump rack stroke. 	-
			<ul style="list-style-type: none"> • Check control system and governor controller. 	-
			<ul style="list-style-type: none"> • Contact your MHIET dealer. 	10
	Engine Body	Wear of sliding parts	<ul style="list-style-type: none"> • Contact your MHIET dealer. 	10

Engine Oil Pressure Drop

Table 11-11 Engine Oil Pressure Drop

Problem	Cause	Remedies	Reference Page	
Engine Oil Pressure Drop	Lubrication System	Low engine oil level	<ul style="list-style-type: none"> • Engine oil level - Check • Check lubrication system. 	149
		Faulty engine oil property (viscosity)	<ul style="list-style-type: none"> • Analyze engine oil properties • Change with the engine oil of proper viscosity. 	- 199
		Excessive engine oil temperature	<ul style="list-style-type: none"> • Cooling system - Check 	-
			<ul style="list-style-type: none"> • Contact your MHIET dealer. 	10
		Clogged oil filter	<ul style="list-style-type: none"> • Check and replace oil filter and bypass oil filter 	151 153
		Oil pump malfunction	<ul style="list-style-type: none"> • Contact your MHIET dealer. 	10
	Relief valve malfunction	<ul style="list-style-type: none"> • Contact your MHIET dealer. 	10	
	Control System	Oil pressure gauge malfunction	<ul style="list-style-type: none"> • Check control system and wiring. 	-
			<ul style="list-style-type: none"> • Contact your MHIET dealer. 	10
		Excessive load	<ul style="list-style-type: none"> • Check fuel injection pump rack stroke. 	-
	<ul style="list-style-type: none"> • Contact your MHIET dealer. 		10	
	Engine Body	Increased wear of sliding parts	<ul style="list-style-type: none"> • Contact your MHIET dealer. 	10
Increased clearance of sliding parts				

Engine Stops

Table 11-12 Engine Stops

Problem	Cause	Remedies	Reference Page
Engine Stops	Run out of fuel	Restart the engine in the following order: <ol style="list-style-type: none"> 1 Turn the start switch to the "ON" position. 2 Fill the fuel tank with fuel. 3 Bleed air from the fuel system. "Fuel System - Bleed Air" (→ Page 134) 4 Operate the start switch of the generator "Starting and Stopping Devices Installed during Manufacturing the Generator" (→ Page 87) to start the engine. 	-

During Normal Operation, Thermo Switch Activated

Table 11-13 During Normal Operation, Thermo Switch Activated

Problem	Cause	Remedies	Reference Page
During Normal Operation, Thermo Switch Activated	Coolant temperature raised	<p>Restart the engine in the following order:</p> <ol style="list-style-type: none"> 1 Operate the engine at low idle speed to cool down immediately. 2 Stop the engine. 3 Check the coolant level. 4 Check the ambient temperature. 5 Bleed air from the cooling system. 6 Check the radiator, fan, and fan belt. 7 Check the coolant temperature. 8 If no fault has been found, restart the engine. <p>Note</p> <ul style="list-style-type: none"> • If any fault is found, contact your MHIET dealer "CONTACT LIST" (→ Page 10). 	-

12 AFTER-SALES SERVICE

This chapter describes the after-sales service.

Supply of Performance Parts for Repair

Supply Period

The supply period is stipulated as 10 years after the end of manufacturing of this engine.

Within this period, the performance parts for repair are always in stock and immediately supplied.

However, some items such as electronic parts may become unavailable before the end of this period due to termination of production by the manufacturer. Contact your MHIET dealer for the availability, price, delivery date, and so on.

Parts That Reached the Supply Period

As a general rule, a performance part for repair which reached its supply period will be terminated for supply.

However, according to the size of the needs and the production situation of the supplier, it may be supplied. In addition, reproduction at your cost may be considered.

When Requesting Repair

If you cannot restore the engine to normal operating condition, in spite that the cause has been identified according to "[11 TROUBLESHOOTING](#)" ([→ Page 179](#)) and the remedies have been taken, disconnect the power supply and contact your MHIET dealer "[CONTACT LIST](#)" ([→ Page 10](#)).

- During the warranty period, we will repair in accordance with the stipulation of the Warranty Policy.
- When the warranty period is expired, parts which will be usable, if repaired, can be repaired at your request and cost.

Inquiry Counter

For repair, inspection and maintenance, contact your MHIET dealer "[CONTACT LIST](#)" ([→ Page 10](#)). At that time, also inform the following items described on the nameplate "[MODEL NAME](#)" ([→ Page 11](#)).

- Serial number
- Model name

13 DISPOSAL

This chapter describes the information for disposal.

Disposal Precautions

■ Fuel - Drain

WARNING



Do not discard waste oil into sewerage, river, lake or other similar places.

* Be sure to discard waste oil in accordance with the applicable laws and regulations.

Keep away from fire, when working with flammable substances such as fuel.

* They may cause a fire.



When working with fuel, wear suitable personal protective equipment such as protective mask, protective eyeglasses, rubber gloves, working clothes with long sleeves and long trousers.

* If fuel comes into contact with your eyes, mouth or skin, it will cause irritation or disorders.

Wipe off spilled flammable substances such as fuel thoroughly with a waste cloth.

* They may cause a fire.

When discarding a waste cloth used to wipe off combustible material, put it into a lidded can and obey the Waste Management and Public Cleansing Act to handle it as a special industrial waste.

* It may cause a fire.

* It could lead to environmental pollution.

* If you violate rules, you may be subject to penalties.

■ Engine Oil - Drain

WARNING



Do not discard waste oil into sewerage, river, lake or other similar places.

* Be sure to discard waste oil in accordance with the applicable laws and regulations.

Keep away from fire, when working with flammable substances such as engine oil.

* They may cause a fire.



When handling engine oil, obey the manufacturer's SDS.

* If engine oil gets in your eyes, it will cause pain and lead to sight loss at the worst.

Wipe off spilled flammable substances such as engine oil thoroughly with a waste cloth.

* They may cause a fire.

When discarding a waste cloth used to wipe off combustible material, put it into a lidded can and obey the Waste Management and Public Cleansing Act to handle it as a special industrial waste.

* It may cause a fire.

* It could lead to environmental pollution.

* If you violate rules, you may be subject to penalties.

■ Coolant (LLC) - Drain

WARNING

 **Do not discard coolant (LLC) into sewerage, river, lake or other similar places.**

* Be sure to discard coolant (LLC) in accordance with the applicable laws and regulations.

Keep away from fire, when working with flammable substances such as coolant (LLC).

* They may cause a fire.

 **When handling coolant (LLC), always wear suitable personal protective equipment such as rubber gloves and protective eyeglasses.**

* If LLC comes into contact with your eyes, it will result in sight loss at the worst.

* If LLC comes into contact with your skin while the engine is hot, you could get burned by heat.

Wipe off spilled flammable substances such as coolant (LLC) thoroughly with a waste cloth.

* They may cause a fire.

When discarding a waste cloth used to wipe off combustible material, put it into a lidded can and obey the Waste Management and Public Cleansing Act to handle it as a special industrial waste.

* It may cause a fire.

* It could lead to environmental pollution.

* If you violate rules, you may be subject to penalties.

■ Anti-corrosive Agent, Rust Preventive Oil, Rust-preventive Fuel - Drain

WARNING

 **Do not discard waste oil into sewerage, river, lake or other similar places.**

* Be sure to discard waste oil in accordance with the applicable laws and regulations.

Keep away from fire, when working with flammable substances such as volatile corrosion inhibitor or rust preventive oil.

* They may cause a fire.

CAUTION

 **When handling volatile corrosion inhibitor or rust preventive oil, wear personal protective equipment such as protective mask or protective glasses, and obey the manufacturer's SDS.**

* If such products are breathed in or comes in contact with the skin, serious personal injury may occur.

■ Battery Fluid (Dilute Sulfuric Acid) - Drain

WARNING

 **Do not discard battery fluid (dilute sulfuric acid) into sewerage, river, lake, or other similar places.**

* Be sure to discard battery fluid (dilute sulfuric acid) in accordance with the applicable laws and regulations.

Never use flames or allow sparks near the battery.

* An explosion due to catching flame or a fire may occur.

 **When checking and servicing the battery, wear suitable personal protective equipment such as protective eyeglasses, rubber gloves, working clothes with long sleeves and long trousers.**

* If battery fluid comes into contact with your eyes or skin, it may result in sight loss or burns.

■ Engine Body - Disposal

⚠ WARNING

! In case that you have to discard the engine body, contact your MHIET dealer.

* You must deal with it as a special industrial waste in accordance with the laws and regulations of the national government and other local municipalities.

Asbestos, mercury, and heavy metal (lead) were used in the parts of the engines that were manufactured in 2005 or earlier. Therefore, when discarding them, obey the "Waste Management and Public Cleansing Act".

* If you violate rules, you may be subject to penalties.

⚠ CAUTION

! While discarding the engine body, be sure to wear the appropriate personal protective equipment.

* Without wearing or not properly wearing personal protective equipment, serious personal injury may occur.

■ Other Disposal

⚠ WARNING

! When discarding a waste cloth used to wipe off combustible materials such as fuel, the engine oil, and coolant (LLC), put it into a lidded can and obey the Waste Management and Public Cleansing Act to handle it as a special industrial waste.

* It may cause a fire.
* It could lead to environmental pollution.
* If you violate rules, you may be subject to penalties.

⚠ CAUTION

! Lift and transport an engine or a heavy object such as tank filled with waste oil or fluid with a forklift only by the qualified operator.

* Otherwise, the heavy object may fall due to improper transportation, and the operator may get injured.
* And the waste oil or fluid leak may occur, which could cause environmental pollution.

Wastes Produced during Inspection and Maintenance

Some wastes produced during inspection or maintenance are subject to control by the laws or regulations of the national government and other local municipalities.

When discarding them, obey the laws or regulations of the national government and other local municipalities and handle them properly, for example, by requesting an industrial waste disposer.

Engine Body - Disposal

In case that you have to discard this engine, contact your MHIET dealer "[CONTACT LIST](#)" (→ Page 10). This engine must be discarded as industrial waste.



Fig. 13-1 Engine Body - Disposal

14 APPENDIX

This chapter describes information about the appendix.

Engine Oil

When using the engine oil other than the genuine ones, use the engine oil which meets "[Engine Oil Quality Standards](#)" ([→ Page 199](#)).

Do not mix and use engine oil of different types and/or manufacturers.

In addition, conduct the oil analysis earlier than the normal change interval and check the change interval.

Note

- **If you use the engine oil which does not meet "[Engine Oil Quality Standards](#)" ([→ Page 199](#)), for fault caused by the engine oil, the warranty will become invalid.**

Engine Oil Quality Standards

Table 14-1 Engine Oil Quality Standards

Item		Unit	Recommended property value	Test method	
API/JASO standards		-	CF grade	-	
SAE viscosity		-	15W-40	-	
ASTM Color		-	L4.0	JIS K 2580	
Density		15°C [59°F]	g/cm ³	0.87 to 0.90	JIS K 2249
Kinetic viscosity		40°C [104°F]	mm ² /s	100 to 110	JIS K 2283
		100°C [212°F]		13.5 to 15.5	
Viscosity index		-	-	JIS K 2283	
Flash point		°C [°F]	225 to 250 [437 to 482]	JIS K 2265	
Base Number	Hydrochloric acid method	Sulfur content in fuel	1.0 mass% or less	10 or more (up to 13)	JIS K 2501
			0.2 mass% or less	8 or more (up to 13)	
	Perchloric acid method		1.0 mass% or less	13 or more (up to 16)	
			0.2 mass% or less	11 or more (up to 16)	
Acid Number		mgKOH/g	1.5 to 2.0	JIS K 2501	
Sulfur content		%	0.5 or less	JIS K 2541	
Sulfuric acid ash		%	2.0 or less	JIS K 2272	
Carbon residue content		%	2.0 or less	JIS K 2270	
High temperature shear viscosity		150°C [302°F]	mPa·S	3.7 or more	JPI-5S-36-91
Pour point		°C [°F]	-25 or less [-13 or less]	JIS K 2269	
Additives	Ca	mass%	0.480 to 0.570	JIS K 0116	
	P		0.050 to 0.070		
	Zn		0.060 to 0.080		
	B		-		
	Si		0.001 or less		
	N		0.030 to 0.060	JIS K 2609	
Bubbling test *1	I	mL	10/0	JIS K 2518	
	II		30/0		
	III		10/0		
Panel coking test *2	300°C [572°F]	mg	140 or less	FED791-3462	
	325°C [617°F]		300 or less		

*1: I test temp. (24°C [75°F]), II test temp. (93.5°C [200°F]), III test temp. (24°C [75°F] after 93.5°C [200°F])

*2: Temperature of aluminum panel: 300°C [572°F] and 325°C [617°F], Temperature of engine oil: 100°C [212°F], Splatter time: 15 seconds, Downtime: 45 seconds, Test time: 8 hours. The properties are the weight of solid product accumulated on the panel.

Service Limit for Engine Oil Properties

■ Kinetic Viscosity

Kinetic viscosity is a basic physical property of engine oil and is considered as the most important factor when evaluating oil.

The kinetic viscosity decreases by contamination with blow-by gas and increases by degradation of oil. Due to increased viscosity, sludge produced in the process accumulates in engine and may cause lubrication oil filter clogging.

Also, the viscosity decreases by contamination with fuel or engine oil and molecular disconnection of the viscosity index improver.

The decreased viscosity causes insufficient lubrication that will cause friction or wear of engine parts.

■ Base Number

Base number shows the ability to neutralize acids such as organic acid due to engine oil oxidation, and sulfurous or sulfuric acid due to the combustion of sulfur content in fuel.

Because the base number indicates the amount of dispersant detergent in oil, it can be used to estimate the consumption of basic dispersant detergent. The ability to disperse sludge declines as the dispersant detergent is consumed. Thus, the base number is often used as an indication of cleaning capability decline.

■ Acid Number

The acid number in oil increases as the organic acid is being derived by the engine oil oxidation, or sulfurous acid or sulfuric acid derived by the combustion of sulfur content of fuel, or the oil becomes contaminated with imperfect combustion products. An increase in the acid number will result in corrosion or wear of the inner parts of the engine (such as cylinder liner and bearing) due to sulfur content, and the piston ring seizure due to sludge.

■ Water Content

Water in oil promotes corrosion/wear, and decreases lubricity in sliding parts.

■ Flash Point

The flash point is lowered by contamination with fuel. Flash point is used to check the fuel dilution of oil. The dilution of oil reduces oil film, and causes insufficient lubrication that will cause friction or wear of engine parts.

■ Insolubles

Insolubles include acid products of engine oil, imperfect combustion products, soot or sludge, worn metal particles and dust. Insolubles value is an indication of degradation/contamination of oil. Dispersant detergent, which is an additive in engine oil, absorbs sludge particles, and disperses them as fine particles in oil. Total insoluble density and remaining dispersibility can be obtained by measuring insoluble and coagulated insoluble (chemical specialties which stop action of disperse detergent and collect the sludge dispersed in oil) to identify the engine oil contamination level, and thereby, the insoluble value can be a marker to prevent the piston ring from seizure or premature wear.

Service Limits for Engine Oil

Engine oil degrades through the use and by the lapse of time. The quality of engine oil and the operating condition of the engine have influence on deterioration of the engine oil.

- Engine oil must be changed at the time stipulated in ["7 SCHEDULED MAINTENANCE"](#) (→ Page 118).
- For the determination of engine oil properties degradation, see the table below.
If any of oil properties exceeds the limit, change the engine oil with new oil.

Table 14-2 Engine Oil Properties

Properties		Standard value		Test standard
Kinetic viscosity	mm ² /s@100°C	Continuous use	+30% or less rate of change from new oil 10 mm ² /s or more	JIS K 2283 ISO 3107 ISO 2909
		Emergency use	+30% or less of the change rate from new oil -20% or more rate of change from new oil	
		For portable	+30% or less of the change rate from new oil -15% or more rate of change from new oil	
Base number	mgKOH/g	2.0 or more by hydrochloric acid (HCL) method 1/2 of new oil or more by the perchloric acid (PCA) method		JIS K 2501 ISO 3771
Acid number	mgKOH/g	+3.0 or less of new oil		JIS K 2501 ISO 3771
Water content	Volume%	0.2 or less		JIS K 2275 ISO 9029
Flash point (open cup)	°C [°F]	180 or more [356 or more]		JIS K 2265 ISO 3679 ISO 2719
Pentane insolubles	mass%	0.5 or less		ASTM D893
Coagulated pentane insolubles	mass%	3.0 or less		ASTM D893

Engine Oil Service Limits for Emergency Use

In case of the engine with long waiting time for operation like emergency use engine, if the fuel level of the fuel tank (fuel day tank) becomes higher than the position of the fuel injection pump, the leak quantity per time increases so that the possibility of dilution increases.

In accordance with the maximum head drop between the fuel level of the fuel tank (fuel day tank) between the position of the fuel injection pump, with or without the water heater, the usage period of the engine varies, in addition, the change interval of the engine oil must be changed accordingly.

Table 14-3 Engine Oil Service Limits for Emergency use

*Maximum head drop (m)	With water heater		Without water heater	
	From 1.0 to 2.0	1.0 or less	From 1.5 to 2.0	1.5 or less
Use limit	1 year	2 years	1 year	2 years

* : The maximum head drop means a vertical distance from the center of the fuel injection pump drive shaft to the fuel level of the fuel tank (fuel day tank) when fuel is filled up to the upper limit.

Coolant

When using the LLC other than genuine ones, use the LLC which meets "[Requirements for LLC](#)" ([→ Page 203](#)) and "[LLC Quality Standard](#)" ([→ Page 203](#)).

Do not mix and use LLC of different types and/or manufacturers.

Note

- **If you use the LLC which does not meet "[Requirements for LLC](#)" ([→ Page 203](#)) and "[LLC Quality Standard](#)" ([→ Page 203](#)), for failures due to LLC, warranty will become invalid.**
- **The quality and performance of commercially available LLC and their component variations are the responsibility of LLC suppliers.**
- **Before purchasing a commercial LLC, be sure to discuss the suitability of LLC with the LLC supplier.**
- **Be sure to use an all-season (non-amine) type long life coolant that prevent freezing of cooling water. Do not use antifreeze alone instead of LLC.**

Requirements for LLC

- LLC must be a homogeneous liquid without sediment.
- When the LLC is diluted to 30 to 60% density, the LLC must not cause any problems such as corrosion and precipitation deposits in the engine cooling system.
- LLC must be mixed well with other non-amine type LLC that meets these requirements and must not separate elements included in each product, and must not decrease the performance of both products.
- LLC must not corrode the container and shall not produce a precipitate when LLC is stored in the container for 6 months.
- LLC must be free from any abnormalities such as precipitates when kept in -20 to -25°C [-4 to -13°F] temperature.

LLC Quality Standard

LLC must be tested in accordance with JIS K 2234, Section 8 "Test method", and satisfy the following table. General matters and specimen sampling method shall comply with JIS K 2234.

Table 14-4 LLC Specifications (1/3)

Test items		Standard value	
External appearance		No precipitation	
Specific gravity		Minimum 1.112 g/cm [69.4199 lb/ft ³] (20/20°C) [20/68°F] (in stock solution)	
Water content		Maximum 5.0 vol% (undiluted solution)	
Freezing temperature	30 volumetric% water solution	-14.5°C [5.9°F] or less	
	50 volumetric% water solution	-34.0°C [-29.2°F] or less	
Equilibrium reflex boiling point		155°C [311°F] or more (undiluted solution)	
pH		7.0 to 11.0 (30 volumetric% water solution)	
Foamability (ASTM D3306-01)	30 volumetric% water solution	4.0 ml or less	
	33 1/3 volumetric% water solution	150 ml or less, defoaming time 5 sec. or less	
Hard water compatibility		1.0 or less (50 volumetric% water solution)	
Corrosiveness to metal (88±2°C [190.4±3.6°F], 336±2 Hr, 30 volumetric% water solution {ethylene glycol}), 50 volumetric% water solution {propylene glycol})	Metallic test piece	Aluminum	± 0.30 mg/cm ²
		Cast iron	± 0.15 mg/cm ²
		Steel	± 0.15 mg/cm ²
		Brass	± 0.15 mg/cm ²
		Solder	± 0.30 mg/cm ²
		Copper	± 0.15 mg/cm ²
		Visual inspection of test piece after testing	Any corrosion must not be observed except for the contacting position of the test piece and spacer. Discoloration is allowed.
		Bubble formation during test	Bubbles must not overflow.
	Property of liquid after test	pH	6.5 to 11.0
		pH change	± 1.0
Precipitation		0.5 volumetric% water solution or less	
Visual inspection of liquid		No significant discoloration. No significant changes such as separation and gel generation.	

Table 14-5 LLC Specifications (2/3)

Test items				Standard value
Circulating corrosion (98±2°C [208.4±3.6°F], 1000 Hr, 30 volumetric% water solution {ethylene glycol}, 50 volumetric% water solution {propylene glycol})	Metallic test piece	Mass change	Aluminum, cast iron, steel, brass, solder, and copper	± 0.30 mg/cm ²
		Visual inspection of test piece after testing		Any corrosion must not be observed except for the contacting position of the test piece and spacer. Discoloration is allowed.
	Property of liquid after test	pH		7.0 to 9.0
		pH change		± 1.0
		Reserve alkalinity change		± 15%
		Precipitation		1.0 volumetric% water solution or less
		Visual inspection of liquid		No significant discoloration. No significant changes such as separation and gel generation.
Ion concentration	Iron, copper, aluminum, zinc, lead, and ammonium ion	10 ppm or less		
Corrosiveness in recirculation (88±3°C [190.4±5.4°F], 1000±2 Hr, 30 volumetric% water solution (ethylene glycol))	Metallic test piece	Mass change	Aluminum	± 0.60 mg/cm ²
			Cast iron	± 0.30 mg/cm ²
			Steel	± 0.30 mg/cm ²
			Brass	± 0.30 mg/cm ²
			Solder	± 0.60 mg/cm ²
			Copper	± 0.30 mg/cm ²
	Visual inspection of test piece after testing		Any corrosion must not be observed except for the contacting position of the test piece and spacer. Discoloration is allowed.	
	Property of liquid after test	pH		6.5 to 11.0
		pH change		Maximum ±1.0
		Visual inspection of liquid		No significant discoloration. No significant changes such as bubbles and gel generation.
	Condition of parts	Pump seals		Free from any malfunction, liquid leak, and abnormal noise during operation.
Pump case inner surfaces and blades		Free from significant corrosion.		

Table 14-6 LLC Specifications (3/3)

Test items		Standard value	
(30 volumetric% water solution, 115°C [239°F], 360 Hr)	Silicone rubber	Tensile strength change rate	-60 to 0%
		Elongation change rate	-40 to +20%
		Volume change rate	0 to +40%
		Hardness change rate*	-20 to +10%
	Nitril rubber	Tensile strength change rate	0 to +10%
		Elongation change rate	-15 to +15%
		Volume change rate	0 to +40%
		Hardness change rate*	-10 to 0%
	Ethylene propylene diene monomer	Tensile strength change rate	0 to +10%
		Elongation change rate	-30 to 0%
		Volume change rate	0 to +10%
		Hardness change rate*	-10 to 0%
Storage stability volumetric% (30 volumetric%, room temperature, 6 Hr)		0.3 or less	

*: Means International Rubber Hardness Degrees (IRHD).

Necessity of LLC

In recent years, with increasing in performance, the engine is inclined to be compact, lightweight, high output power, low sparing on fuel and low emission, however engine coolant is used under severe conditions such as continuous long operation, high temperature, high flow rate and others.

Furthermore, many different materials such as steel, aluminum, copper, solder, and rubber are used in the cooling system, and they are also subject to the severe conditions described above. Those materials have different ionization characteristics, and this difference accelerates corrosion through the medium of engine coolant. To prevent such a problem, it is necessary to use the LLC containing additives that prevent rust.

Characteristics of LLC Additives

LLC contains several chemicals in such proportions as to produce chemical reactions that suppress corrosion (ionization) of engine parts that contact with the coolant. LLC loses its effectiveness by hours of use as well as lapse of time.

Furthermore, if the chemicals are not well proportioned to match the metals used in the cooling system, certain chemicals in the LLC become rapidly used up, and it results in corrosion of metals to be protected. Consequently, other corrosion preventing chemicals react with dissolving metals, by which corrosion is accelerated. This condition generates more severe corrosion than when plain soft water is used. This is a typical problem caused by the use of inappropriate LLC.

Examples of Abnormalities Caused by LLC (Amine Type)

■ Corrosion of Iron Parts

Amines are generally effective in suppressing the rusting of ferrous metals, but they are said to cause problems for copper parts. If copper corrosion occurs in the cooling system due to lowering of copper type antirust, dissolved copper will deposit on iron parts. A difference in electrical potential occurs between the copper deposits and the iron, causing corrosion of iron which has a higher ionization characteristics, resulting in problems such as pitting at an early stage.

■ Corrosion of Aluminum Parts

Silicate is highly effective in protecting aluminum against rusting. However, it is unstable in a solution in which the pH is 9 or less, and can turn to gel and precipitate in the solution. For this reason, the pH is usually specified to be about 10 to ensure a high alkaline level. This means, after silicate is used up, the high alkalinity causes chemical attacks on aluminum. To prevent this problem, proper maintenance of the coolant is required. For example, rapid wear of the water pump mechanical seal due to gelification of silicate salt has been observed.

■ Pitting and Clogging of Heat Exchanger

When LLC deteriorates or when its concentration in the coolant becomes low, the anti-corrosion performance of LLC lowers and it results in the corrosion of metals.

Brass and solder tend to corrode faster than other metals, and corrosion of these metals is said to cause troubles such as water leak and clogging in the heat exchanger.

Mitsubishi Diesel Engine S16R OPERATION & MAINTENANCE MANUAL

Issued in December 2021

Pub. No. 290Y1-40220 Revision: 4

Issued by Mitsubishi Heavy Industries Engine & Turbocharger, Ltd.
3000, Tana, Chuo-ku, Sagamihara, Kanagawa, 252-5293, Japan

Edited by MHI Sagami High-tech LTD.

Printed and bound by Fuji Film Service Link Co., Ltd.

-
- The manual with incorrect collating or missing pages is to be replaced.
 - Without written approval from the publisher, for all or some part of this manual, unauthorized reproduction, copy, reprinting in any way or method are prohibited.



December 2021

OPERATION & MAINTENANCE MANUAL **SI6R**

For EPA Certified Engine

Pub. No. 290Y1-40220

