

BLUE STAR

Power Systems Inc.

Diesel Product Line

208-600 Volt

VD600-03

60 Hz / 1800 RPM

600 kWe

Standby

Ratings

	208V	240V	480V	600V
Phase	3	3	3	3
PF	0.8	0.8	0.8	0.8
Hz	60	60	60	60
Generator Model	S6L1D-C	S6L1D-C	HCI534E	HCI534F
Connection	12 LEAD WYE	12 LEAD DELTA	12 LEAD WYE	4 LEAD WYE
kWe	600	600	600	600
AMPS	2084	1806	903	723
Temp Rise	125°C / 40°C	125°C / 40°C	125°C / 40°C	125°C / 40°C

Standard Equipment

Engine

- Radiator Cooled Unit Mounted (55°C)
- Radiator Duct Flange (OPU Only)
- Blower Fan & Fan Drive
- Starter & Alternator
- Oil Pump & Filter
- Oil Drain Extension w/Valve
- Governor - Electronic Isochronous
- 24V Battery System & Cables
- Air Cleaner (Dry Single Stage)
- Critical Grade Silencer Mounted
- Flexible Fuel Connector
- EPA Certified Tier 2

Generator

- Brushless Single Bearing
- Automatic Voltage Regulator
- ± 0.50% Voltage Regulation
- 4 Pole, Rotating Field
- 125°C Standby Temperature Rise
- 100% of Rated Load - One Step
- 5% Maximum Harmonic Content
- NEMA MG 1, IEEE and ANSI Standards Compliance for Temperature Rise

Additional

- Single Source Supplier
- UL 2200 & cUL Listed
- CSA Certified
- Seismic Certified to IBC 2021
- NFPA 110 / CSA C282 Compliant
- Microprocessor Based Digital Control Panel Mounted in NEMA 12 Enclosure
- Base - Structural Steel
- Main Line Circuit Breaker Mounted & Wired
- Battery Charger 24V 5 Amp
- Jacket Water Heater -20°F 5000W 240V w/Isolation Valves
- Vibration Isolation Mounts (Pad Type)
- 2 Year / 2000 Hour Standby Warranty
- Standard Colors - White / Gray

Application Data

Engine

Manufacturer:	Volvo Penta	Displacement - Cu. In. (lit):	984 (16.1)
Model:	TWD1644GE	Bore - in. (cm) x Stroke - in. (cm):	5.67 (14.4) x 6.50 (16.5)
Type:	4-Cycle	Compression Ratio:	16.8:1
Aspiration:	Turbo Charged, H2O to Air CAC	Rated RPM:	1800
Cylinder Arrangement:	6 Cylinder Inline	Max HP Stby (kWm):	917 (674)

Exhaust System

Standby

Gas Temp. (Stack): °F (°C)	923 (495)
Gas Volume at Stack Temp: CFM (m³/min)	4,044 (114)
Maximum Allowable Exhaust Restriction: in. H ₂ O (kPa)	40.2 (10.0)

Cooling System

Ambient Capacity of Radiator: °F (°C)	131 (55.0)
Maximum Allowable Static Pressure on Rad. Exhaust: in. H ₂ O (kPa)	0.50 (0.12)
Water Pump Flow Rate: GPM (lit/min)	95.4 (361)
Heat Rejection to Coolant: BTUM (kW)	13,990 (245)
Heat Rejection to CAC: BTUM (kW)	8,360 (146)
Heat Radiated to Ambient: BTUM (kW)	12,050 (211)

Air Requirements

Aspirating: CFM (m³/min)	1,649 (46.7)
Air Flow Required for Rad. Cooled Unit: CFM (m³/min)	28,198 (798)
Air Flow Required for Heat Exchanger/Rem. Rad. CFM (m³/min)	Consult Factory For Remote Cooled Applications

Fuel Consumption

At 100% of Power Rating: gal/hr (lit/hr)	39.2 (148)
At 75% of Power Rating: gal/hr (lit/hr)	30.4 (115)
At 50% of Power Rating: gal/hr (lit/hr)	21.0 (79.3)

Fluids Capacity

Total Oil System: gal (lit)	12.7 (48.0)
Engine Jacket Water Capacity: gal (lit)	6.60 (25.0)
System Coolant Capacity: gal (lit)	39.9 (151)

Deration Factors: Rated Power is available up to 4,920 Ft (1,500 m) at ambient temperatures to 122°F (50°C). Consult factory for site conditions above these parameters.

DCP7310 Control Panel

Standard Features

- Digital Metering
- Engine Parameters
- Generator Protection Functions
- Engine Protection
- CAN Bus (J1939) ECU Communications
- Windows-Based Software
- Multilingual Capability
- Remote Communications to DSE2548 Remote Annunciator
- 8 Programmable Contact Inputs
- 10 Contact Outputs
- RS485 Communicator Interface
- cULus Listed, CE Approved
- Event Recording
- IP 65 rating (with supplied gasket) offers increased resistance to water ingress
- NFPA 110 Level 1 Compatible



Weights / Dimensions / Sound Data

	L x W x H	Weight lbs
OPU	150 x 78 x 100 in	10,775
Level 1	200 x 78 x 110 in	12,600
Level 2	200 x 78 x 110 in	12,700
Level 3	255 x 78 x 110 in	13,200

Please allow 6-12 inches for height of exhaust stack.

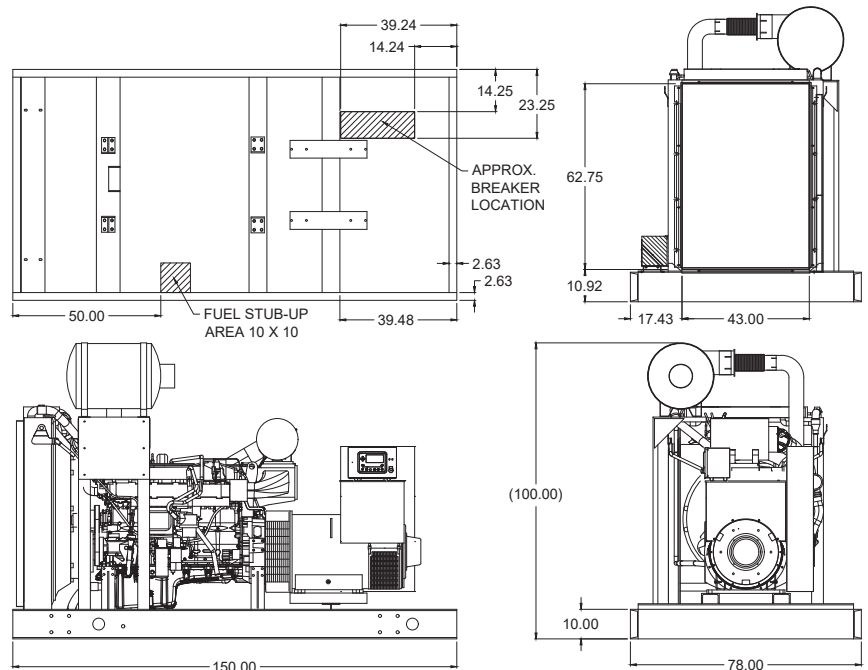

	No Load	Full Load
OPU	92 dBA	94 dBA
Level 1	87 dBA	90 dBA
Level 2	82 dBA	84 dBA
Level 3	74 dBA	76 dBA

Enclosures & Fuel Tanks

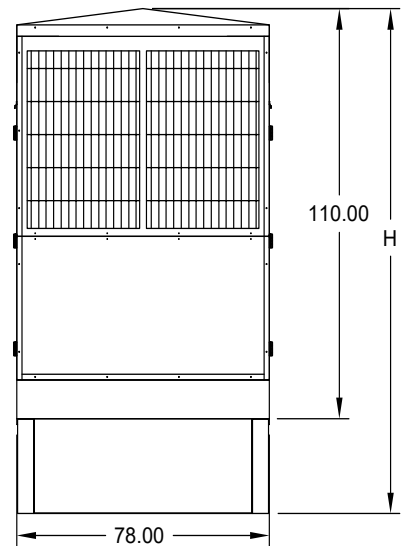
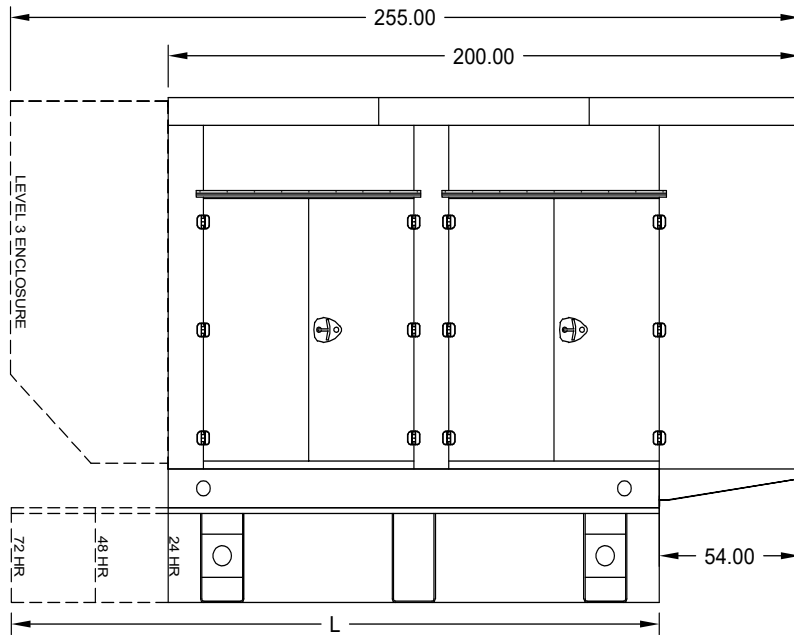

- All enclosure models are 200 MPH wind rating certified in accordance with IBC2021 and ASCE/SEI 7-16 standards.
- Level 2 & 3 enclosures include sound attenuation foam
- Level 3 enclosure includes frontal sound & exhaust hood.
- Enclosure height does not include exhaust stack.

	24 Hour 900 Gallon	48 Hour 1800 Gallon	72 Hour 2700 Gallon
L	150.00	228.00	336.00
H	140.00	146.00	146.00

Notes

- All specification sheet dimensions are represented in inches.
- All drawings based on standard 480 volt standby generator. Lengths may vary with other voltages. All drawings and dimensions subject to change without notice.
- All enclosures and fuel tanks are based on the standard unit configuration. Any requested deviation can change dimensions.
- Sound data is measured at 23 feet (7 meters) in accordance with ISO 8528-10.
- All materials and specifications subject to change without notice.

American Owned



American Made

Blue Star Power Systems, Inc.

2250 Carlson Drive

North Mankato, Minnesota 56003

Phone + 1 507 345 1776

bluestarps.com

quote.bluestarps.com

sales@bluestarps.com