

DRAWING: PD750-01-LV0

**\*\*CONSULT FACTORY FOR 208V  
3PH AND 240V 3PH  
DIMENSIONS\*\***

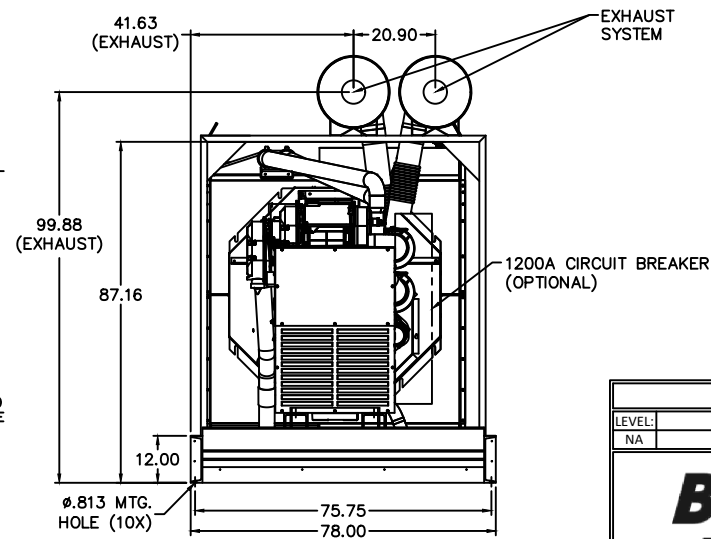
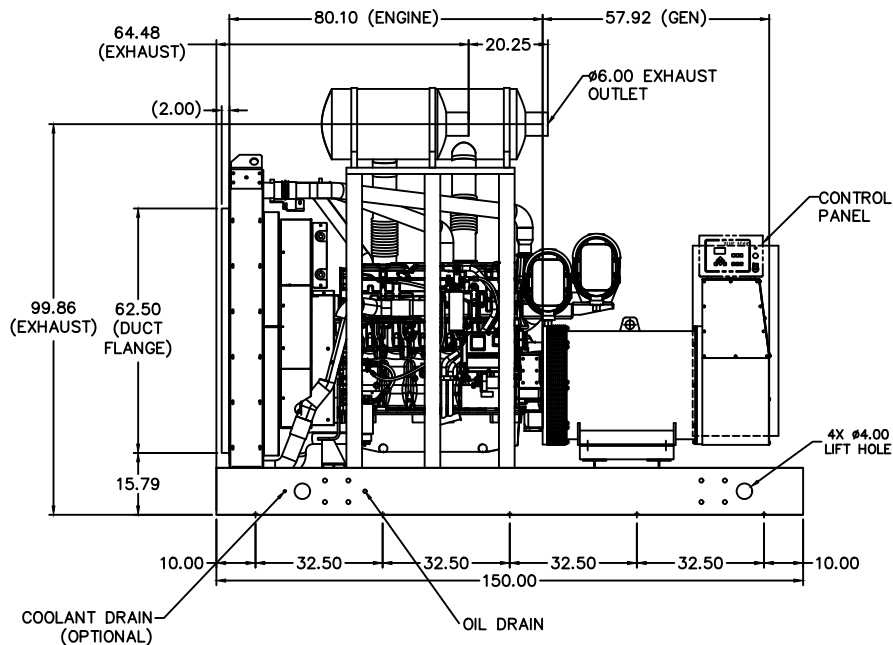
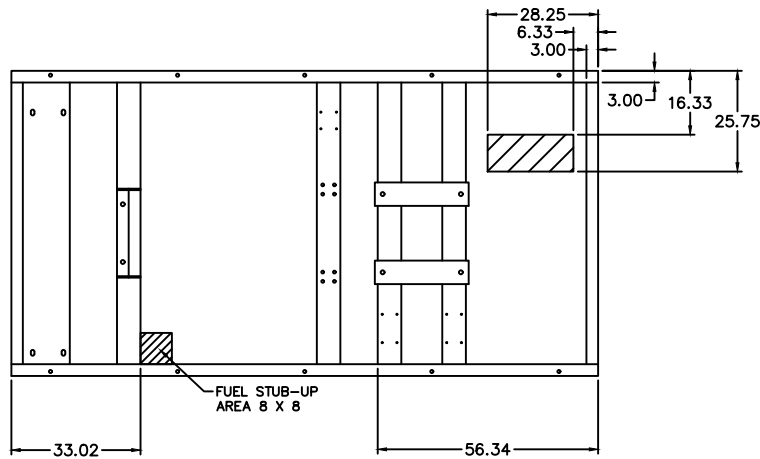

- NOTES:  
 1. BREAKER LOCATION IS APPROXIMATE  
 2. DUCT FLANGE WIDTH: 63.75"  
 3. FUEL SUPPLY: 5/8" FUEL RETURN: 3/8"  
 4. (XX.XX) DIMENSIONS ARE FOR REFERENCE ONLY

REVISIONS:

LEVEL:	DESCRIPTION:	DATE:	BY:
NA	NA	NA	NA

**BLUE STAR**  
 Power Systems Inc.

ENG: 2806C-E18TTAG7		GEN: 573	
RAD: W/ ENG	BASE: 23577	HSG: NA	
DATE: 02-22-21		BY: CLJ	DRAWN TO SCALE