

# BLUE STAR

## Power Systems Inc.

### Gaseous Product Line

208-600 Volt

NG300-01

60 Hz / 1800 RPM

300 kWe

Standby

### Ratings

	208V	240V	480V	600V
<b>Phase</b>	3	3	3	3
<b>PF</b>	0.8	0.8	0.8	0.8
<b>Hz</b>	60	60	60	60
<b>Generator Model</b>	S4L1D-E41	S4L1D-E41	S4L1D-D41	S4L1S-D4
<b>Connection</b>	12 LEAD WYE	12 LEAD DELTA	12 LEAD WYE	4 LEAD WYE
<b>kWe Nat (LP)</b>	300 (200)	300 (200)	300 (200)	300 (200)
<b>AMPS Nat (LP)</b>	1042 (695)	903 (602)	452 (301)	361 (241)
<b>Temp Rise</b>	125°C / 40°C	125°C / 40°C	125°C / 40°C	125°C / 40°C

### Standard Equipment

#### Engine

- Radiator Cooled Unit Mounted (50°C)
- Radiator Duct Flange (OPU Only)
- Blower Fan & Fan Drive
- Starter & Alternator
- Oil Pump & Filter
- Oil Drain Extension w/Valve
- Governor - Electronic Isochronous
- 24V Battery System & Cables
- Air Cleaner (Dry Single Stage)
- Catalyst / Silencer Mounted
- Flexible Fuel Connector
- EPA Certified

#### Generator

- Brushless Single Bearing
- Automatic Voltage Regulator
- ± 0.50% Voltage Regulation
- 4 Pole, Rotating Field
- 125°C Standby Temperature Rise
- 100% of Rated Load - One Step
- 5% Maximum Harmonic Content
- NEMA MG 1, IEEE and ANSI Standards Compliance for Temperature Rise

#### Additional

- Single Source Supplier
- UL 2200 & cUL Listed
- CSA Certified
- Seismic Certified to IBC 2021
- NFPA 110 / CSA C282 Compliant
- Microprocessor Based Digital Control Panel Mounted in NEMA 12 Enclosure
- Base - Structural Steel
- Main Line Circuit Breaker Mounted & Wired
- Battery Charger 24V 5 Amp
- Jacket Water Heater -20°F 4000W 240V w/Isolation Valves
- Vibration Isolation Mounts (Pad Type)
- 2 Year / 2000 Hour Standby Warranty
- Standard Colors - White / Gray

### Application Data

#### Engine

Manufacturer:	Power Solutions International	Displacement - Cu. In. (lit):	891 (14.6)
Model:	14.6L	Bore - in. (cm) x Stroke - in. (cm):	5.04 (12.8) x 5.59 (14.2)
Type:	4-Cycle	Compression Ratio:	10.5 : 1
Aspiration:	Turbo Charged, CAC	Rated RPM:	1800
Cylinder Arrangement:	8 Cylinder Vee	Max HP Stby (kWm):	456 (340)

#### Exhaust System

#### Standby

Gas Temp. (Stack): °F (°C)	1,005 (541)
Gas Volume at Stack Temp: CFM (m³/min)	1,531 (43.3)
Maximum Allowable Exhaust Restriction (Post Catalyst): in. H <sub>2</sub> O (kPa)	11.5 (2.88)

#### Cooling System

Ambient Capacity of Radiator: °F (°C)	122 (50.0)
Maximum Allowable Static Pressure on Rad. Exhaust: in. H <sub>2</sub> O (kPa)	0.50 (0.12)
Water Pump Flow Rate: GPM (lit/min)	139 (526)
Heat Rejection to Coolant: BTUM (kW)	16,099 (282)
Heat Rejection to CAC: BTUM (kW)	2,006 (35.1)
Heat Radiated to Ambient: BTUM (kW)	6,097 (107)

#### Air Requirements

Aspirating: CFM (m³/min)	547 (15.5)
Air Flow Required for Rad. Cooled Unit: CFM (m³/min)	29,970 (848)
Air Flow Required for Heat Exchanger/Rem. Rad. CFM (m³/min)	Consult Factory For Remote Cooled Applications

#### Standby

#### Fuel Consumption

#### Natural Gas

#### LP

At 100% of Power Rating: ft <sup>3</sup> /hr (m <sup>3</sup> /hr)	3,269 (92.5)	933 (26.4)
At 75% of Power Rating: ft <sup>3</sup> /hr (m <sup>3</sup> /hr)	2,563 (72.5)	745 (21.1)
At 50% of Power Rating: ft <sup>3</sup> /hr (m <sup>3</sup> /hr)	1,862 (52.7)	554 (15.7)
Fuel Inlet Size: NPT		3.00"
Fuel Pressure Required: in. H <sub>2</sub> O (kPa)		11.0 (2.75)

#### Fluids Capacity

Total Oil System: gal (lit)	8.19 (31.0)
Engine Jacket Water Capacity: gal (lit)	9.50 (36.0)
System Coolant Capacity: gal (lit)	31.6 (120)

All calculations based on natural gas fuel.

Deration Factors: Temperature: Derate 1.5% Per 10°F Over 77°F Air Inlet Temperature | Altitude: Derate 2.5% Per 1,000 ft Over 1,200 ft

## DCP7310 Control Panel

### Standard Features

- Digital Metering
- Engine Parameters
- Generator Protection Functions
- Engine Protection
- CAN Bus (J1939) ECU Communications
- Windows-Based Software
- Multilingual Capability
- Remote Communications to DSE2548 Remote Annunciator
- 8 Programmable Contact Inputs
- 10 Contact Outputs
- RS485 Communicator Interface
- cULus Listed, CE Approved
- Event Recording
- IP 65 rating (with supplied gasket) offers increased resistance to water ingress
- NFPA 110 Level 1 Compatible



## Weights / Dimensions / Sound Data

	L x W x H	Weight lbs
<b>OPU</b>	140 x 78 x 90 in	9,200
<b>Level 1</b>	140 x 78 x 96 in	10,625
<b>Level 2</b>	140 x 78 x 96 in	10,725
<b>Level 3</b>	200 x 78 x 96 in	11,775

Please allow 6-12 inches for height of exhaust stack.

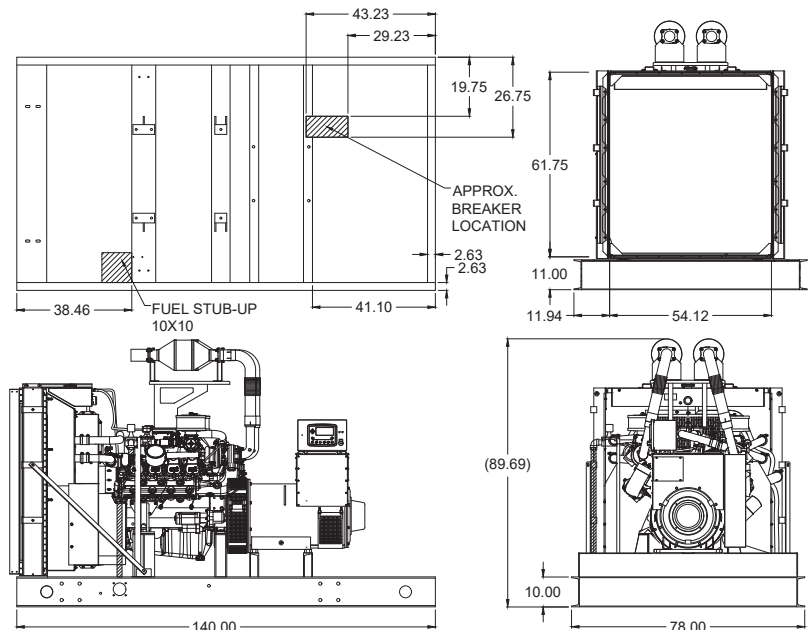

	No Load	Full Load
<b>OPU</b>	82 dBA	85 dBA
<b>Level 1</b>	80 dBA	82 dBA
<b>Level 2</b>	75 dBA	77 dBA
<b>Level 3</b>	70 dBA	72 dBA

## Enclosures

Level 1 & 2 | Side View (Weather Proof)

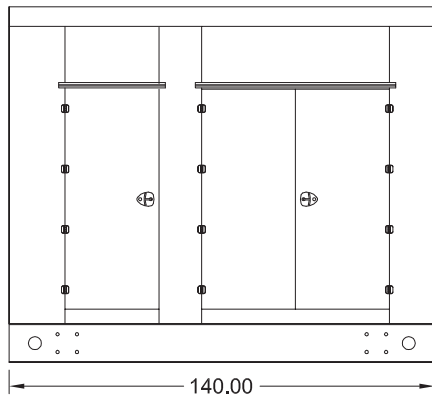

Level 3 | Side View (Sound Attenuated)

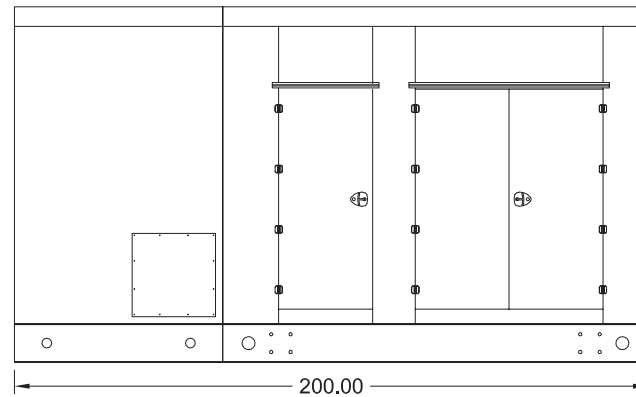

Level 1, 2 & 3 | Intake View

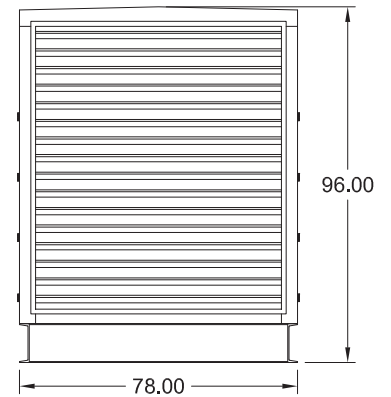

- All enclosure models are 200 MPH wind rating certified in accordance with IBC2021 and ASCE/SEI 7-16 standards.
- Level 2 & 3 enclosures include sound attenuation foam
- Level 3 enclosure includes frontal sound & exhaust hood.
- Enclosure height does not include exhaust stack.

### Notes

- All specification sheet dimensions are represented in inches.
- All drawings based on standard 480 volt standby generator. Lengths may vary with other voltages. All drawings and dimensions subject to change without notice.
- All enclosures are based on the standard unit configuration. Any requested deviation can change dimensions.
- Sound data is measured at 23 feet (7 meters) in accordance with ISO 8528-10.
- All materials and specifications subject to change without notice.

American Owned



American Made

**Blue Star Power Systems, Inc.**

2250 Carlson Drive

North Mankato, Minnesota 56003

Phone + 1 507 345 1776

bluestarps.com

quote.bluestarps.com

sales@bluestarps.com