

12HR TANK
MD800, MD 1000
LV3

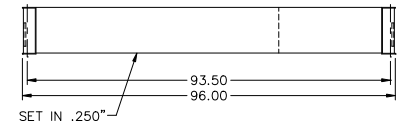
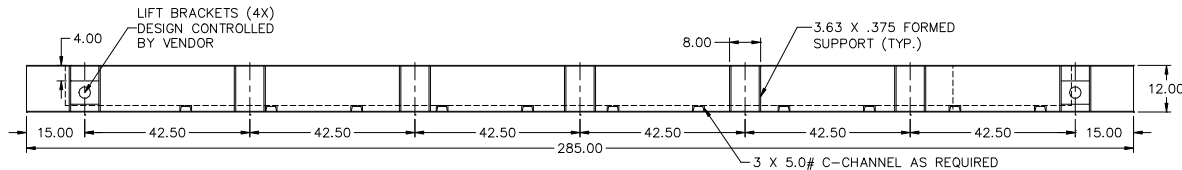
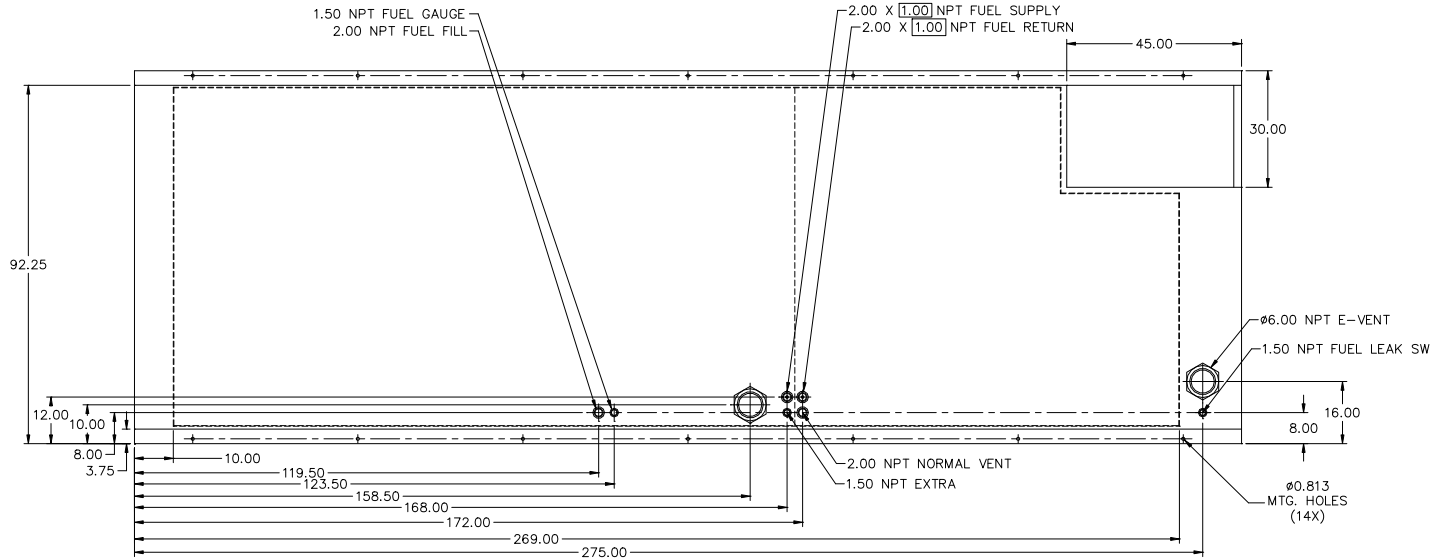

- NOTES:
- MATERIAL: 7GA. RUPTURE BASIN
7GA. INNER TANK
 - SECONDARY CONTAINMENT TANK
 - FINISH PAINT GLOSS BLACK
 - TANK TO INCLUDE
 - FUEL SUPPLY / RETURN DIP TUBES
 - LIFTING / TIE DOWN BRACKETS
 - FUEL NPT SUPPLY/RETURN 2.00 X 1.00

APPROXIMATE WEIGHT: 5200 LBS

REVISIONS:

LEVEL:	DESCRIPTION:	DATE:	BY:
01	MOVED FUEL FILL INSIDE DOORWAY	07-05-16	KAP

BLUE STAR
Power Systems Inc.

TANK SB 900GL DW UL W/STUB-UP

P/N: 20923	285"L X 96"W X 12"H
DATE: 07-15-16	BY: KDH DRAWN TO SCALE