

**12HR TANK  
MD800, MD1000  
LV0/LV1/LV2**

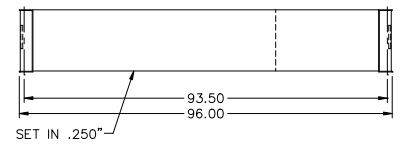
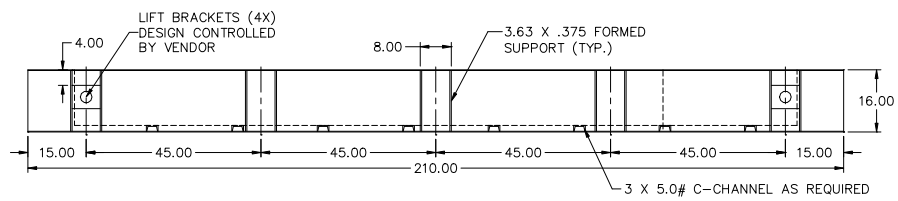
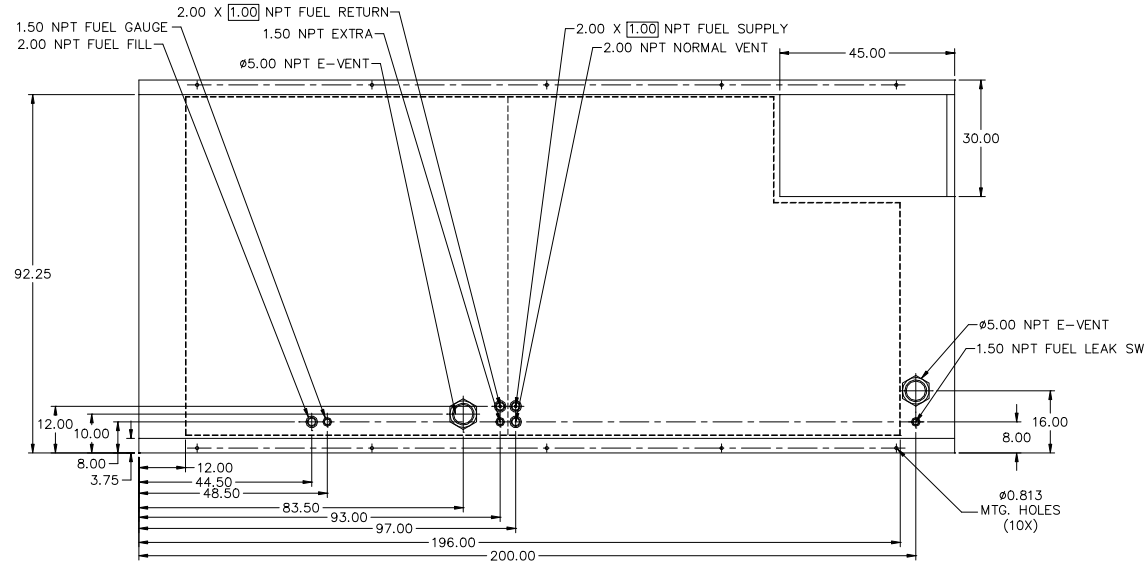

- NOTES:
1. MATERIAL: 7GA. RUPTURE BASIN  
7GA. INNER TANK
  2. SECONDARY CONTAINMENT TANK
  3. FINISH PAINT GLOSS BLACK
  4. TANK TO INCLUDE
    - FUEL SUPPLY / RETURN DIP TUBES
    - LIFTING / TIE DOWN BRACKETS
  5. FUEL NPT SUPPLY/RETURN 2.00 X 1.00

APPROXIMATE WEIGHT: 4200 LBS

| REVISIONS: |  |          |     |
|------------|--|----------|-----|
| LEVEL:     | DESCRIPTION:                                     | DATE:    | BY: |
| 01         | MOVE FITTINGS TO STANDARDIZE LOCATIONS, MATERIAL | 07-15-16 | KAP |

**BLUE STAR**  
Power Systems Inc.

**TANK SB 900GL DW UL W/STUB-UP**

|                |                        |
|----------------|------------------------|
| P/N: 20922     | 210"L X 96"W X 16"H    |
| DATE: 07-15-16 | BY: KDH DRAWN TO SCALE |