

VUE GAUCHE / LEFT VIEW

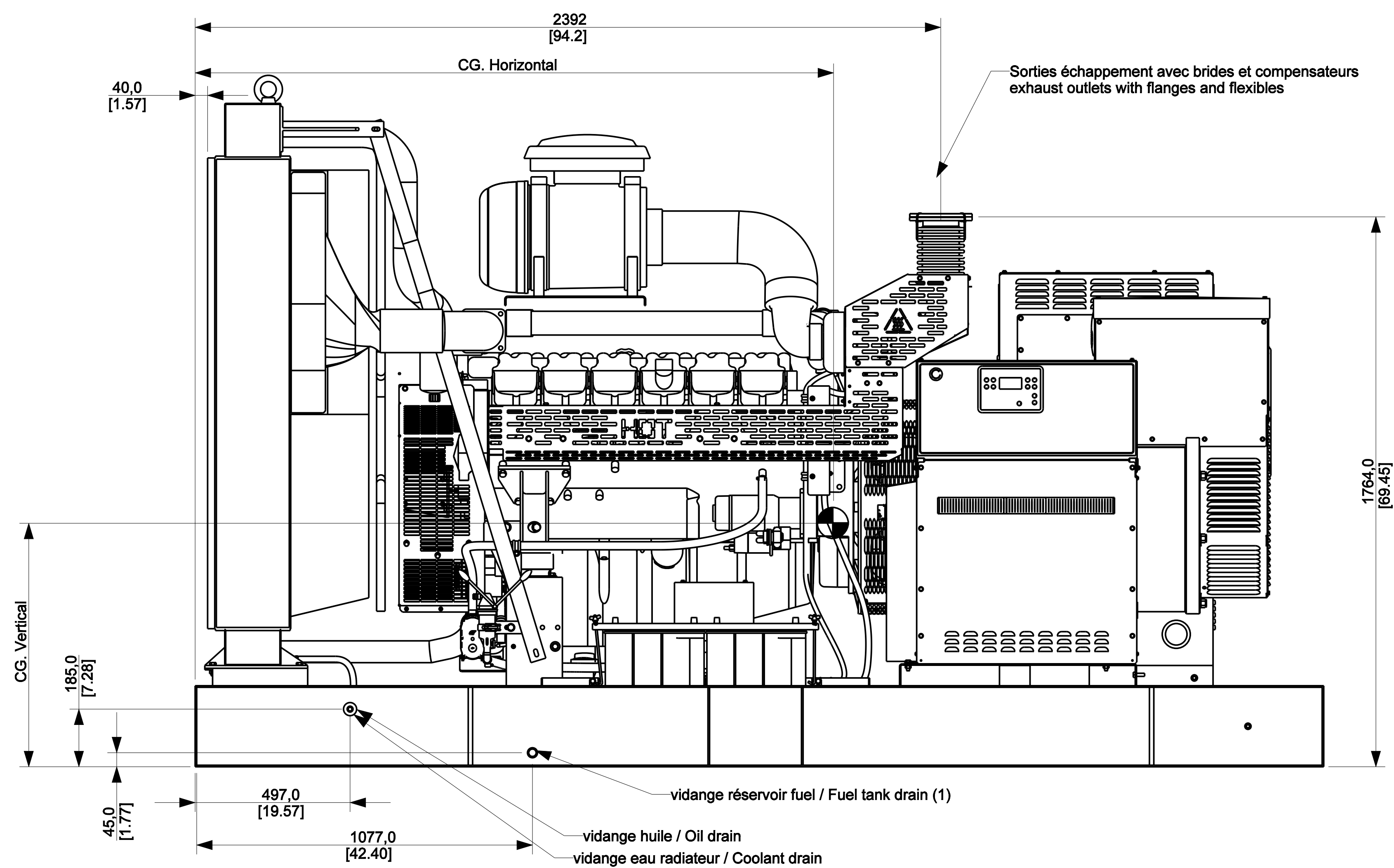

VUE FACE / FRONT VIEW

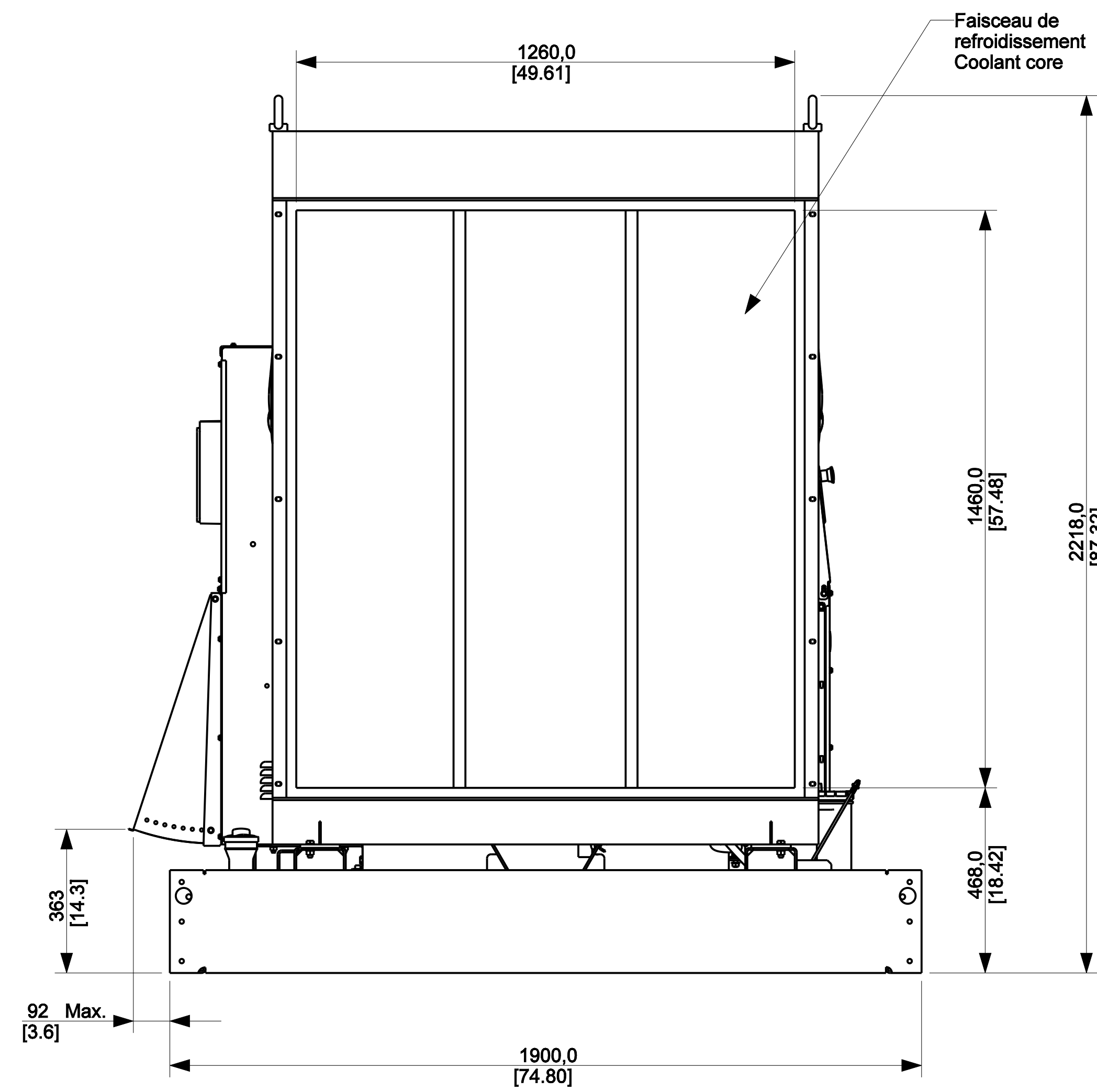

VUE DROITE / RIGHT VIEW

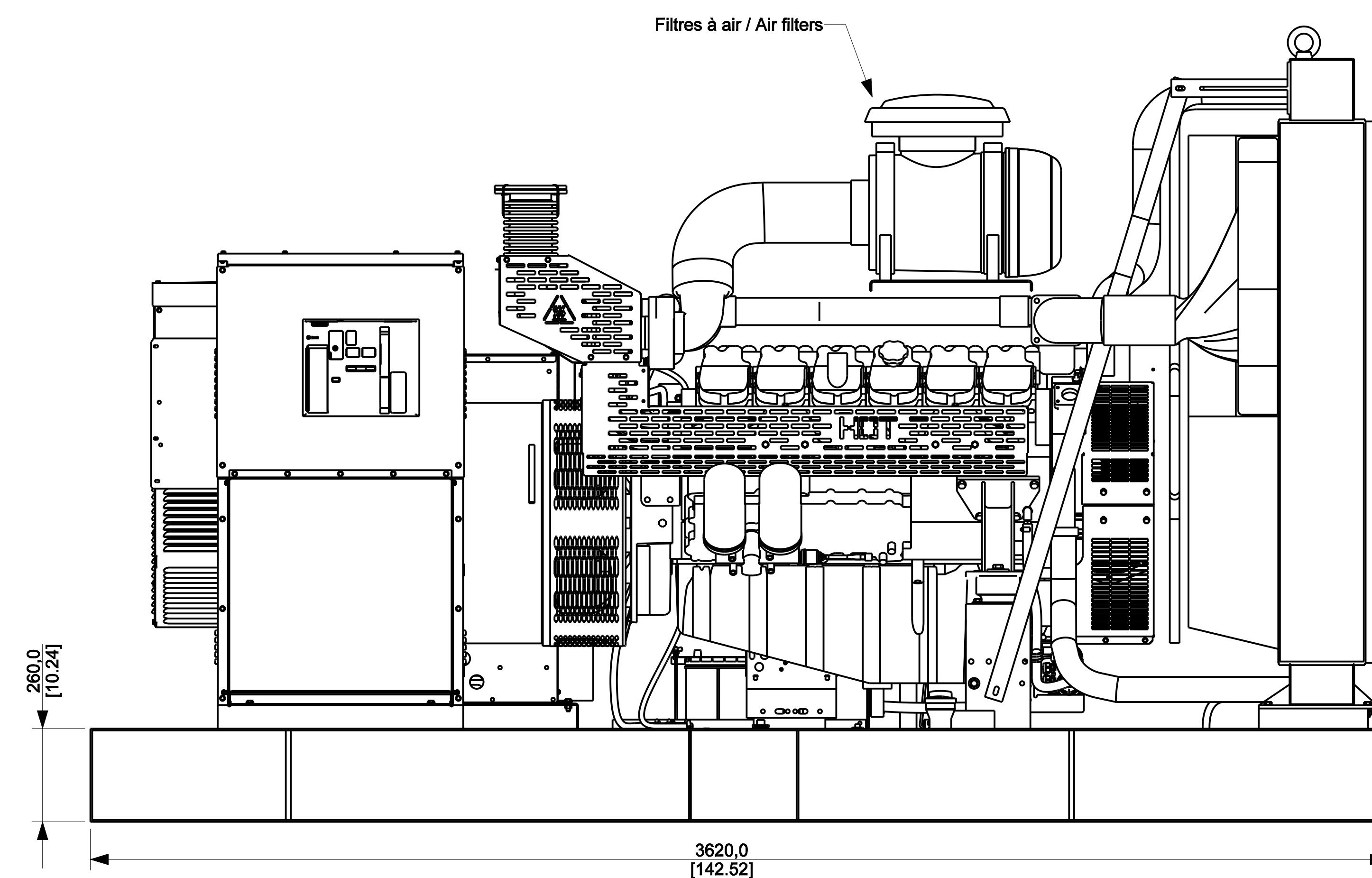

VUE DESSUS / TOP VIEW

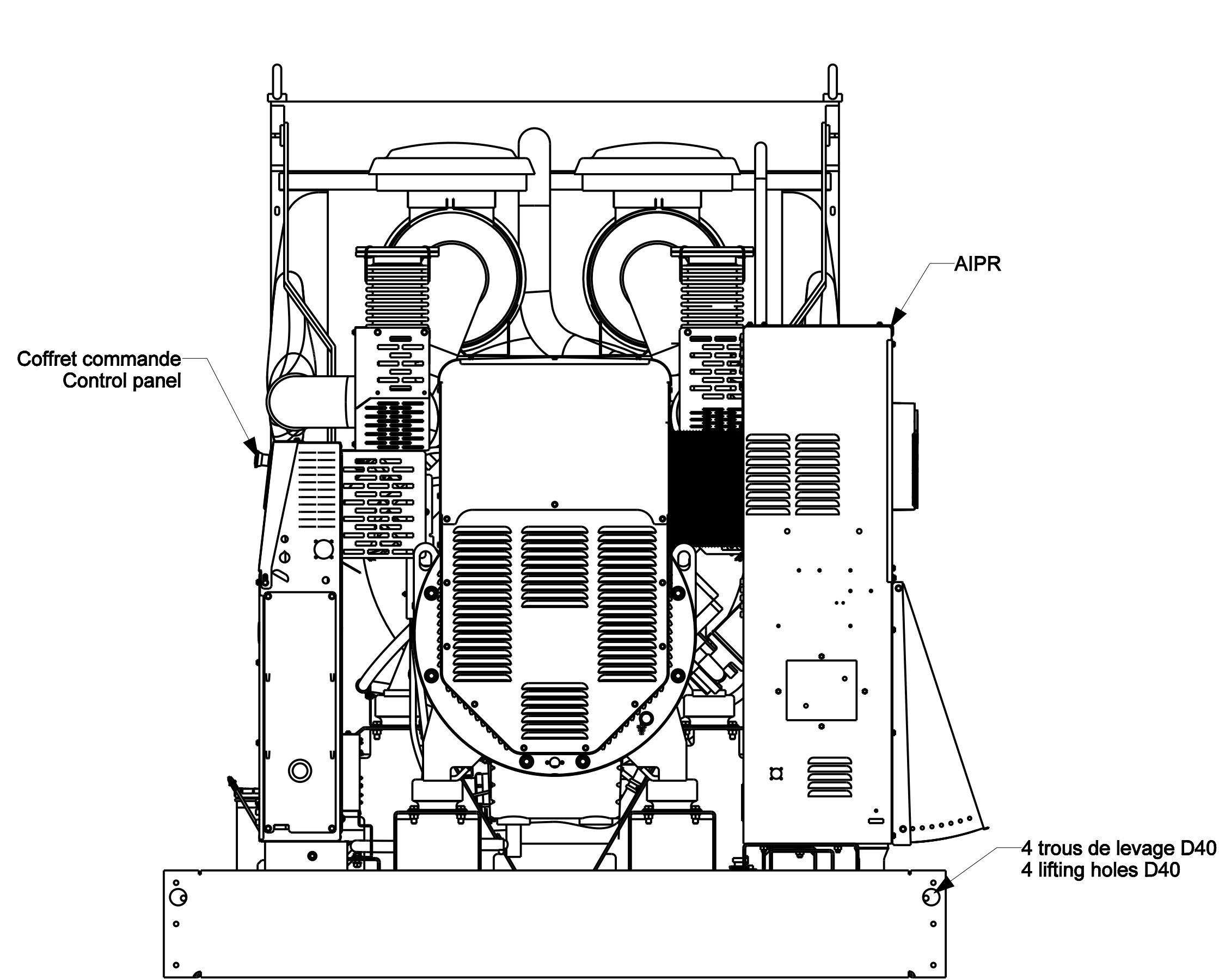
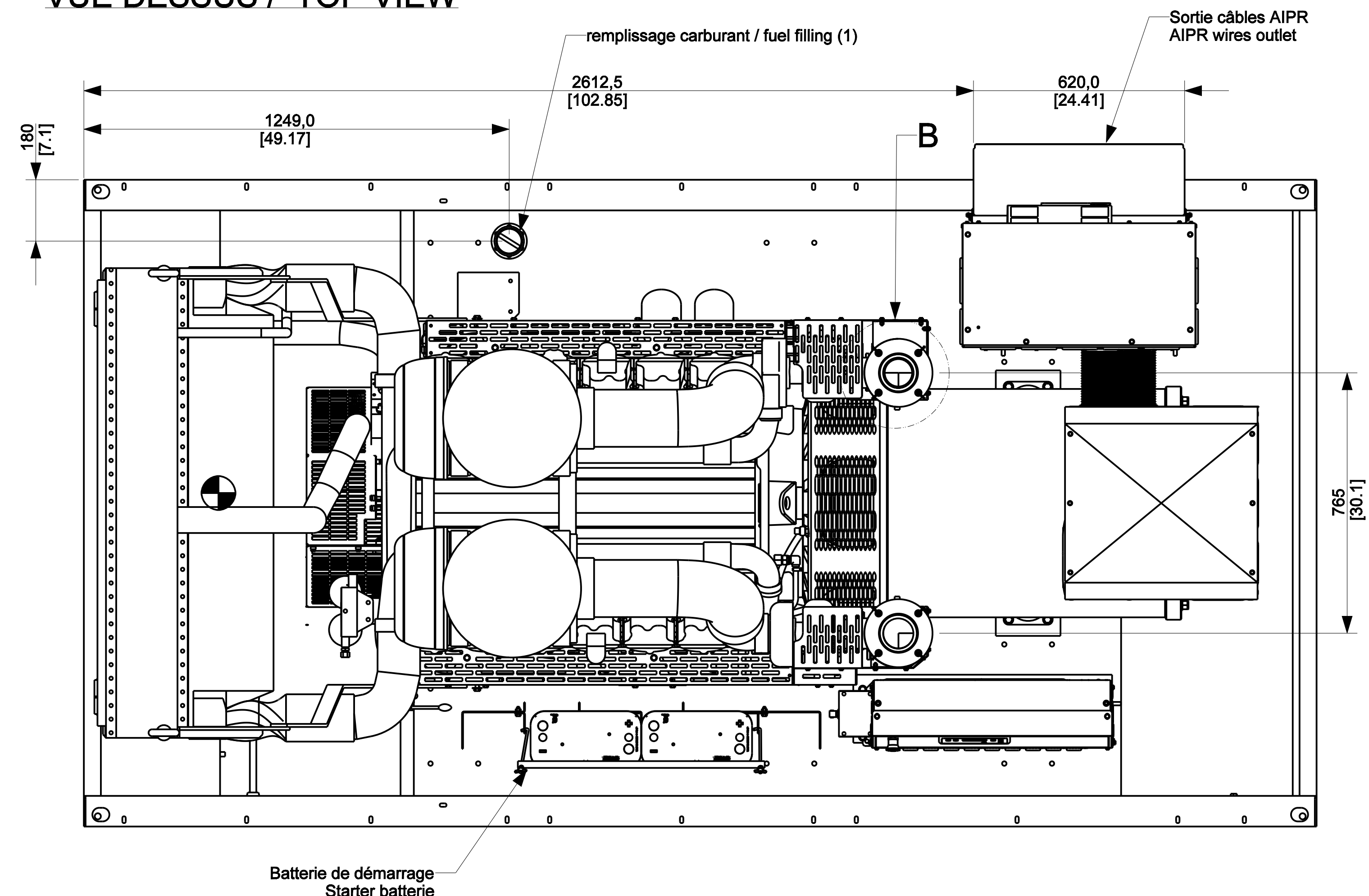

VUE ARRIERE / REAR VIEW

Sortie échappement / Exhaust outlet

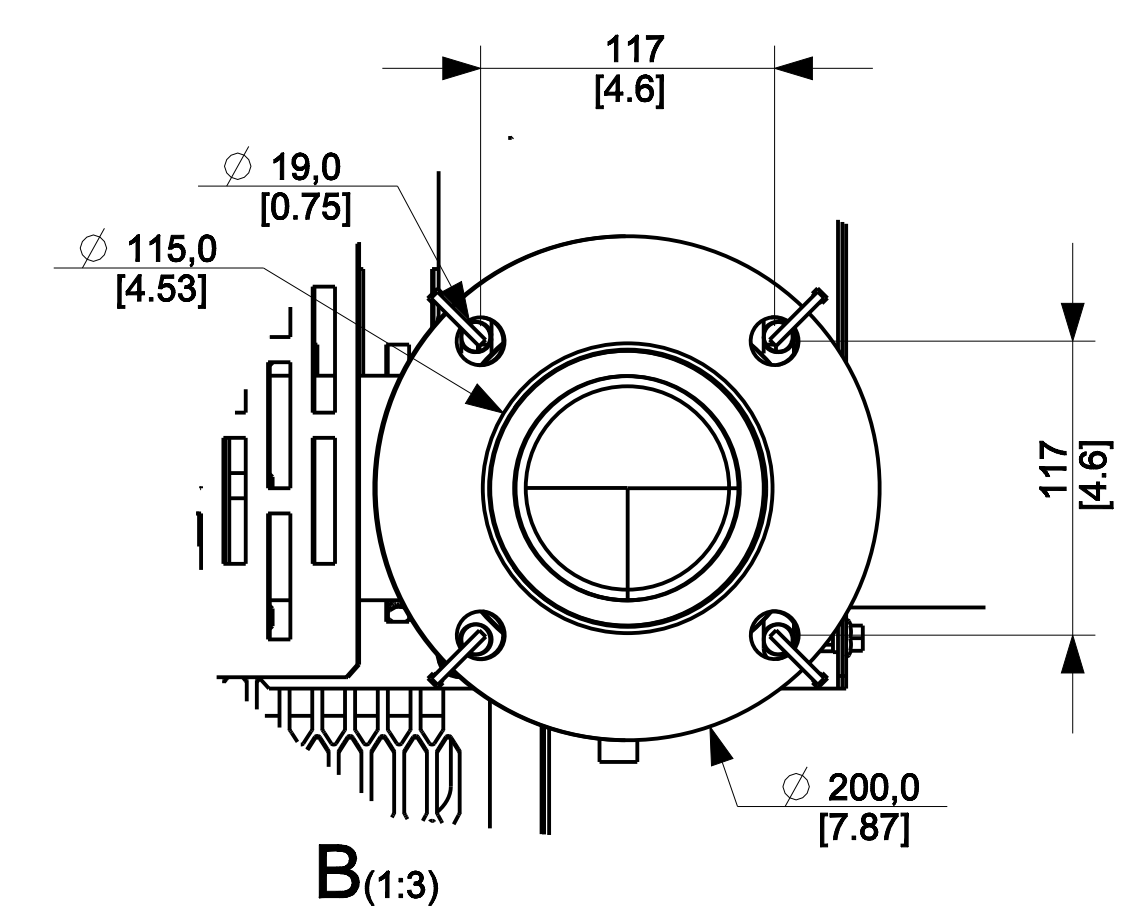

MOTEUR / ENGINE	ALTERNATEUR / ALTERNATOR	CHASSIS AVEC RESERVOIR GASOIL / FRAME WITH FUEL TANK					
		MASSE / WEIGHT (kg / lbs) +/- 5%		COG (mm / inch) A vide / Dry		COG (mm / inch) OdM / Wet	
		A vide / Dry	OdM / Wet	CG Horizontal	CG Vertical	CG Horizontal	CG Vertical
DOOSAN DP222LC	KH03546T	4340 / 9568	5042 / 11115	2094 / 82.44	827 / 32.55	2126 / 83.70	770 / 30.31

MOTEUR / ENGINE	ALTERNATEUR / ALTERNATOR	CHASSIS SANS RESERVOIR GASOIL / FRAME WITHOUT FUEL TANK					
		MASSE / WEIGHT (kg / lbs) +/- 5%		COG (mm / inch) A vide / Dry		COG (mm / inch) OdM / Wet	
		A vide / Dry	OdM / Wet	CG Horizontal	CG Vertical	CG Horizontal	CG Vertical
DOOSAN DP222LC	KH03546T	4293 / 9464	4479 / 9874	2083 / 82.00	1137 / 44.76	2084 / 82.047	1136 / 44.72

(1) Seulement avec châssis réservoir fuel / Only with fuel tank frame

- Voir folios suivants pour informations complémentaires / See following sheets for additional informations.

- Les noms des vues correspondent aux différentes faces du groupe électrogène / The names of the views correspond to the different sides of the generating set.

REV. DATE ON COMPOSITE DWGS, SEE PART NO. FOR REVISION LEVEL BY DO NOT SCALE, REFERENCE THE MODEL FOR ALL UNSPECIFIED DIMENSIONS

UNLESS OTHERWISE SPECIFIED - 1) DIMENSIONS ARE IN MILLIMETERS 2) TOLERANCES ARE: NF ISO 13260-A4

APPROVALS DATE 01-Jun-22 CAD NO: 30001545901 SCALE: 1:10 SHEET: 1 of 3

DRAWN P. SIMON CHECKED APPROVED DWG NO.: 30001545901

TITLE: 30001545901

THIS DRAWING IS UNDER PROPERTY OF THE COMPANY. IT CANNOT BE PRINTED, USED OR COMMUNICATED WITHOUT ITS AUTHORIZATION.

270 rue de Koenigsmann - 29490 Guipavas CS 40047 - 29801 Brest Cedex 3 - France

KOHLER

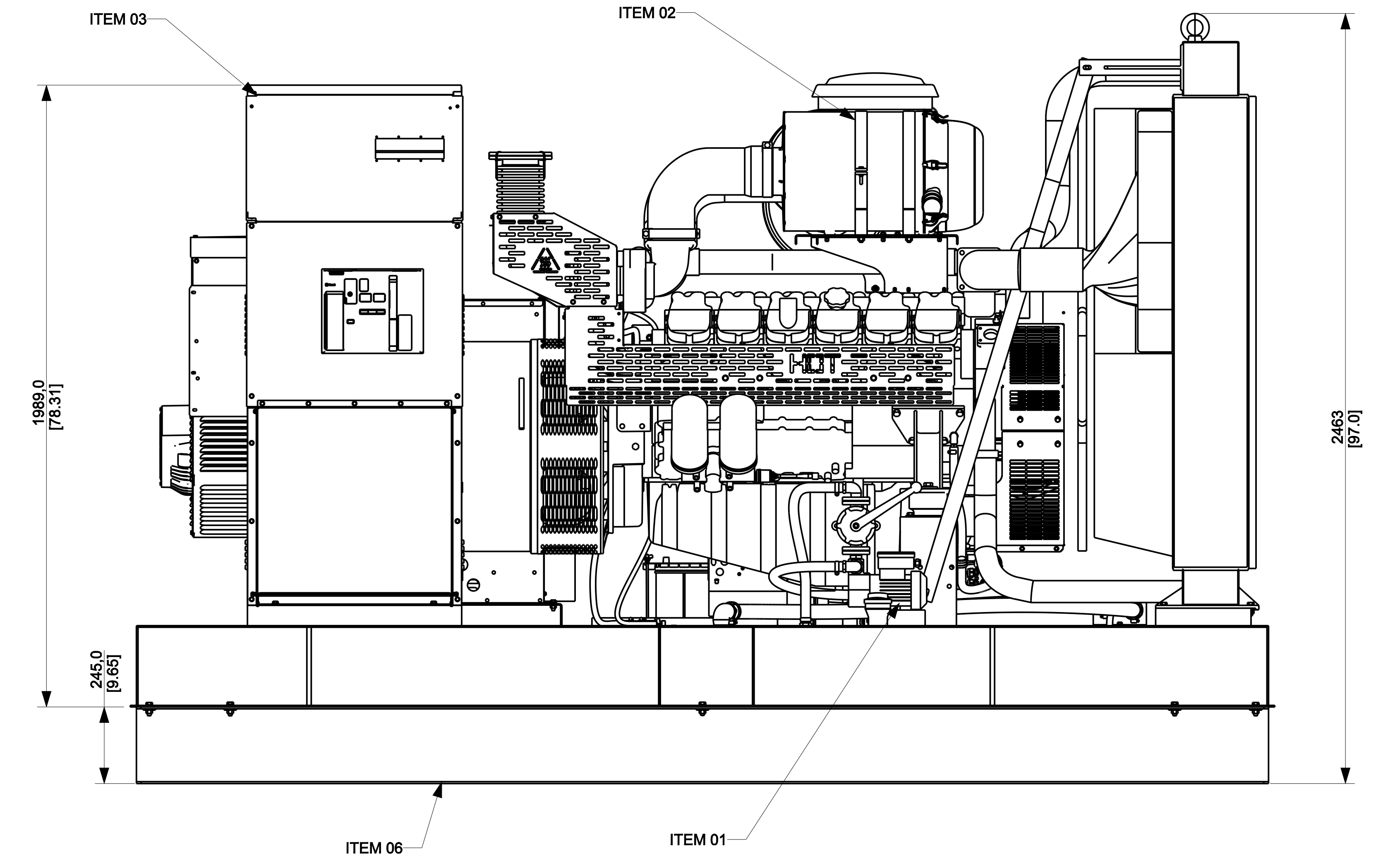
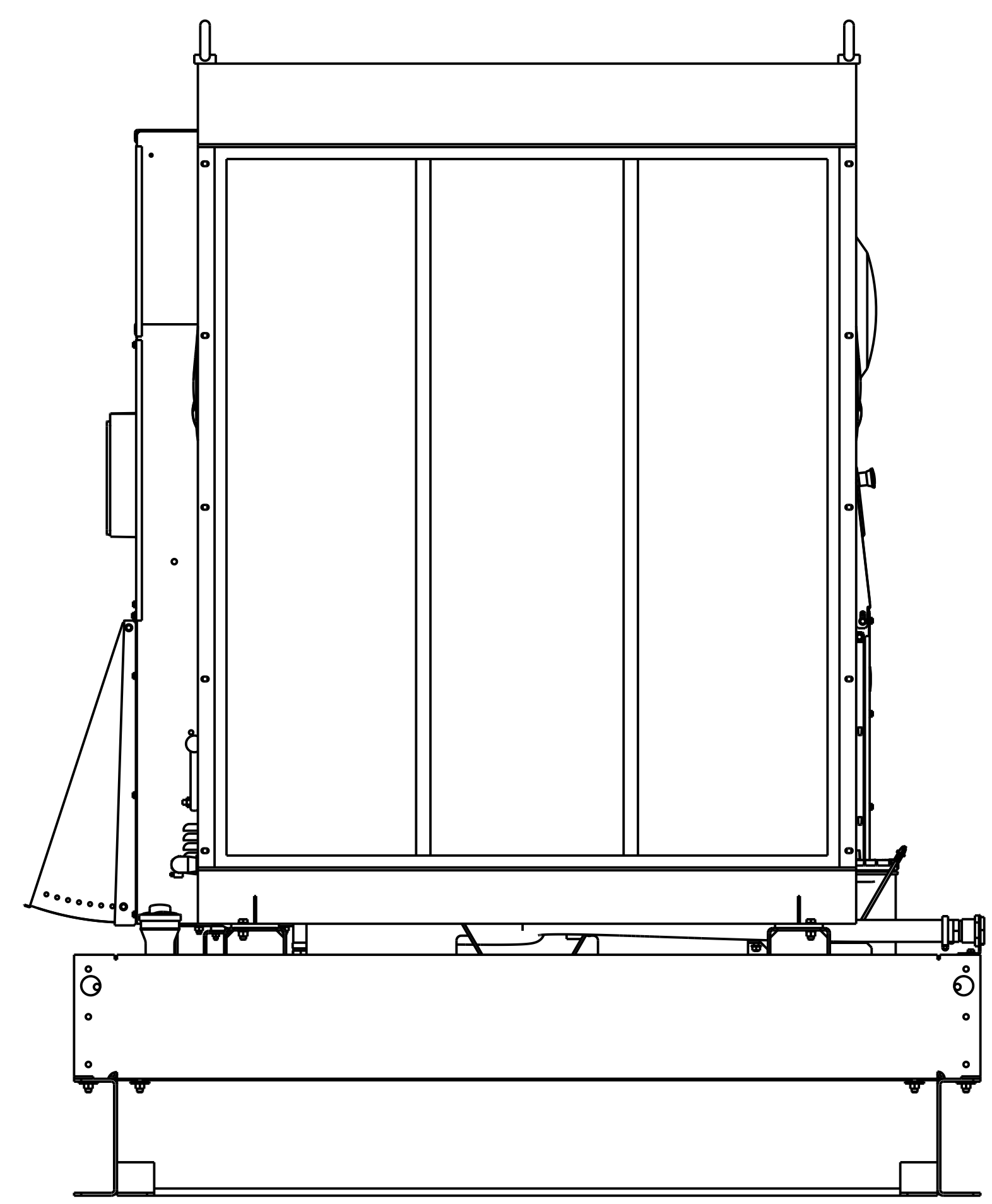
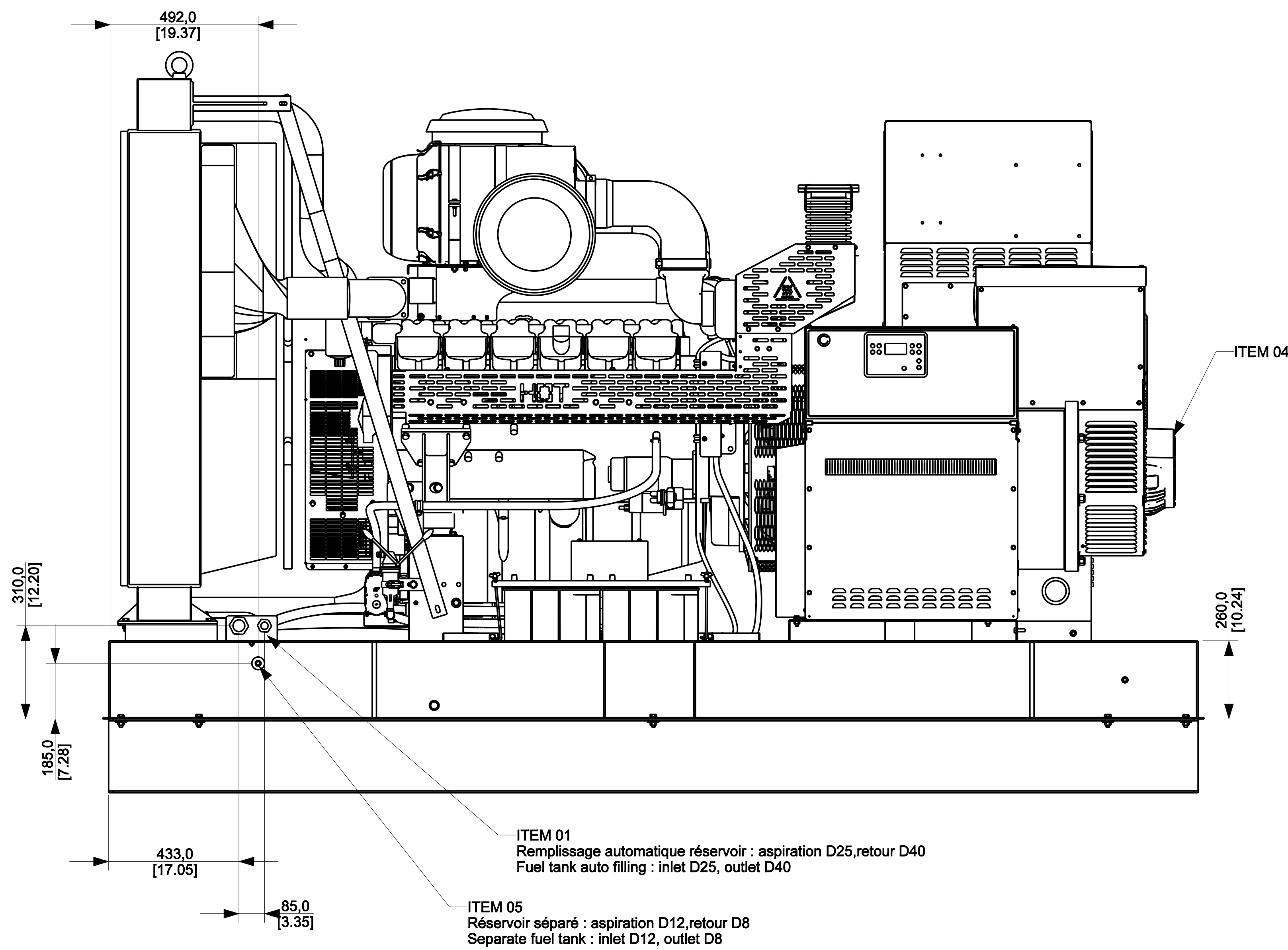

INFORMATIONS SUPPLEMENTAIRES / ADDITIONAL INFORMATION	ITEM
KIT REPLISSAGE FUEL AUTOMATIQUE / AUTOMATIQUE FUEL FILL KIT	01
FILTRE A AIR AMBIANCE POUSSIEREUSE / HEAVY DUTY AIR FILTER	02
ARMOIRE AIPR SUPERIEUR / UPPER BRAKER BOX	03
PMG ALTERNATEUR / ALTERNATOR PMG	04
RACCORDEMENT FUEL SEPARÉ / FUEL CONNECTION	05
BAC DE RETENTION / RETENTION BUND	06

CET ASSEMBLAGE OU PIECE DOIT ETRE CONFORME A LA SPECIFICATION PEP-RML-001
THIS ASSEMBLY OR PART MUST COMPLY WITH SPECIFICATION PEP-RML-001

REV	DATE	ON COMPOSITE DWGS, SEE PART NO. FOR REVISION LEVEL	BY	DO NOT SCALE, REFERENCE THE MODEL FOR ALL UNSPECIFIED DIMENSIONS
-	02/06/22	NEW DRAWING	SP	UNLESS OTHERWISE SPECIFIED - 1) DIMENSIONS ARE IN MILLIMETERS 2) TOLERANCES ARE: NF B01300-A4-E

KOHLER. 270 rue de Koenigsm - 26490 Guéret
CS 4007 - 2601 Guéret Cedex 9 - France

THIS DRAWING IS UNDER PROPERTY OF THE COMPANY.
IT CANNOT BE PRINTED, USED OR COMMUNICATED WITHOUT ITS AUTHORIZATION.

TITLE: **30001545901** SCALE: 1:10 SHEET: 2 of 3

DRAWN: P. SIMON DATE: 01-Jun-22 CAD NO.: 30001545901 REV.: - SIZE: A0

APPROVED: APPROVED: DWG NO.: **30001545901**

Dimensions de transport / Delivery size

Version châssis avec ou sans réservoir -> Sans bac de rétention
With or without tank frame version -> Without retention bund

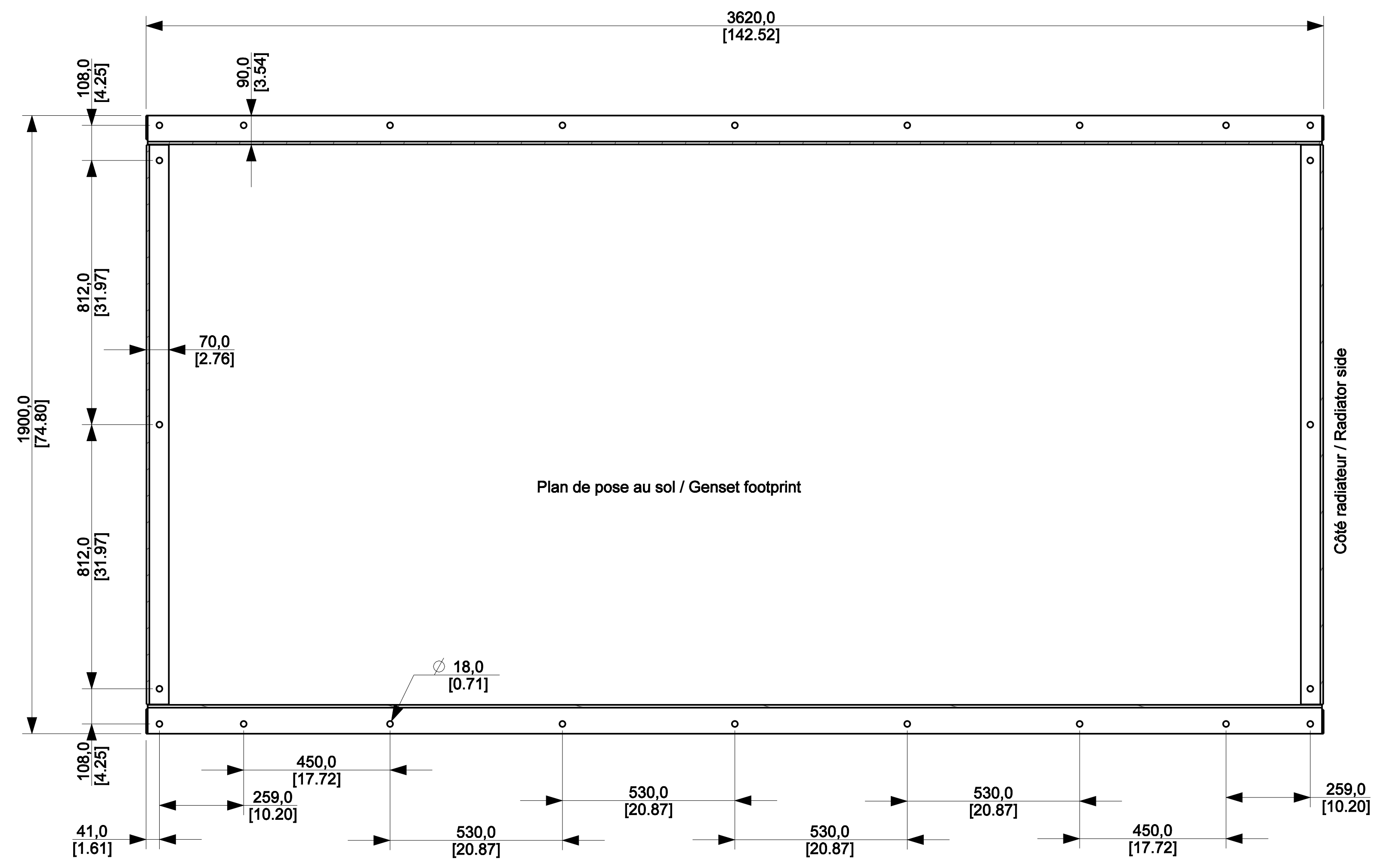
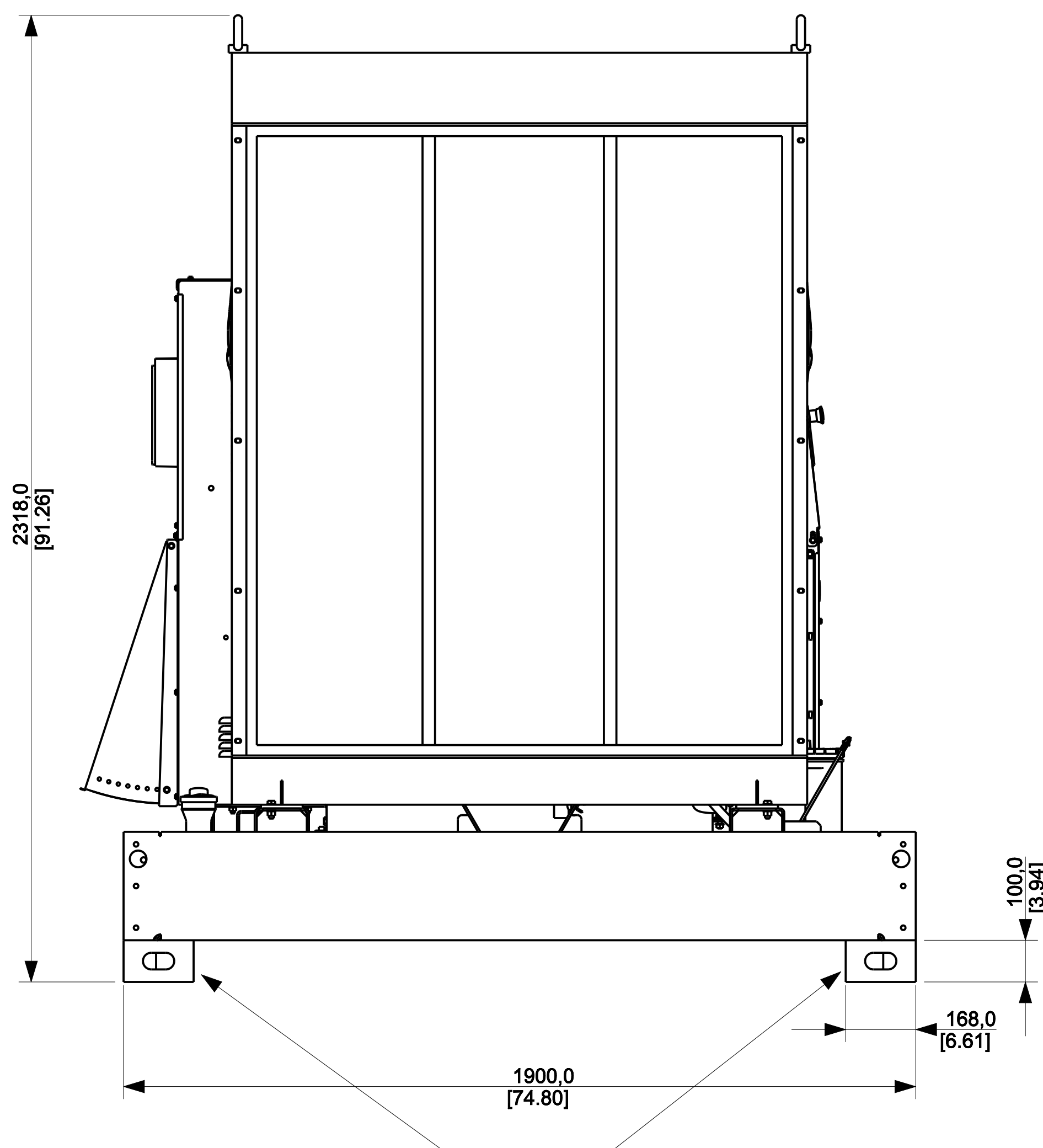
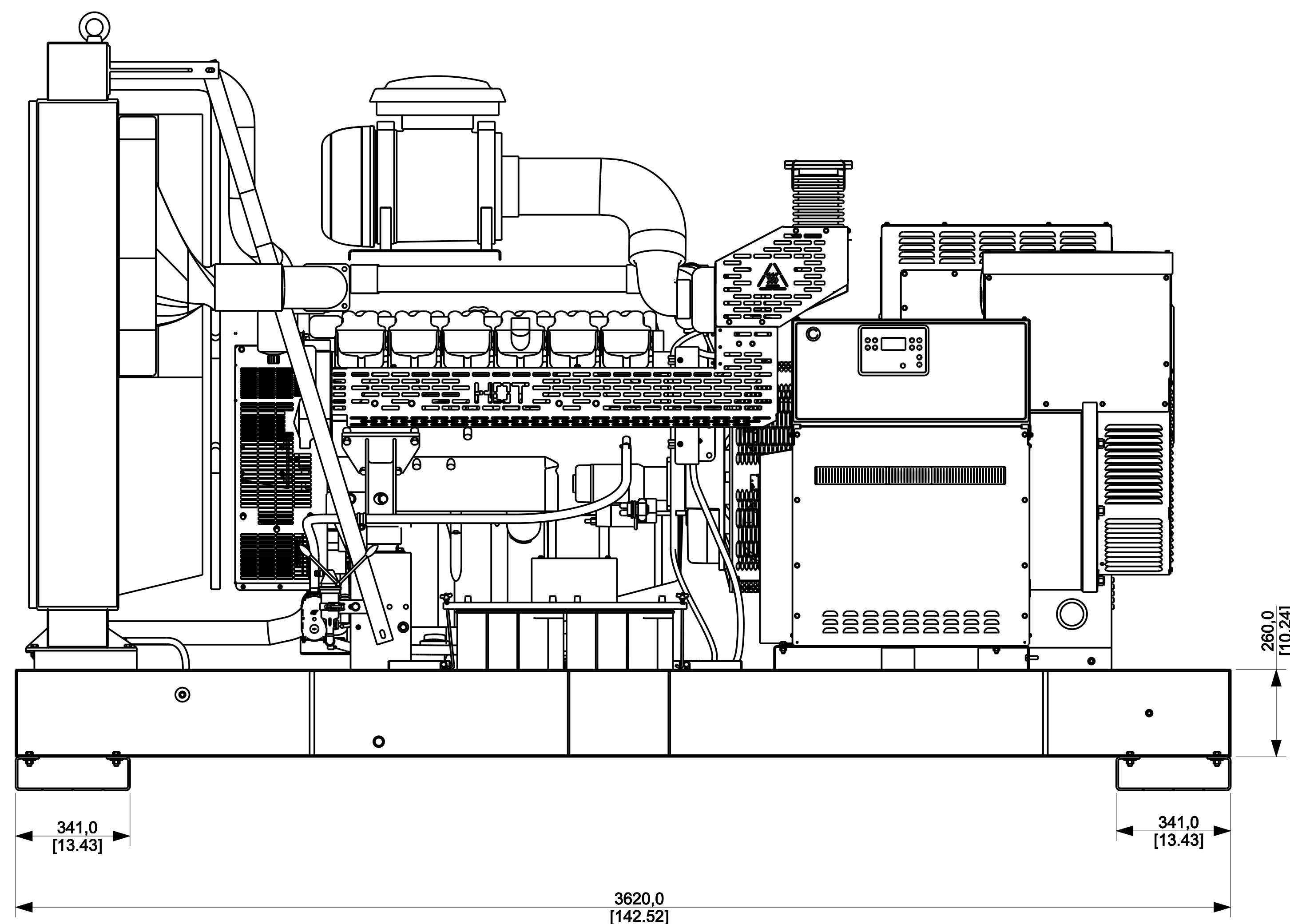

Eléments de manutention uniquement pour le transport à démonter pour l'installation du groupe électrogène
Handling devices only for transportation must be unfitted to install the generator set

Dimensions de transport / Delivery size

Version châssis avec ou sans réservoir -> Avec bac de rétention
With or without tank frame version -> With retention bund

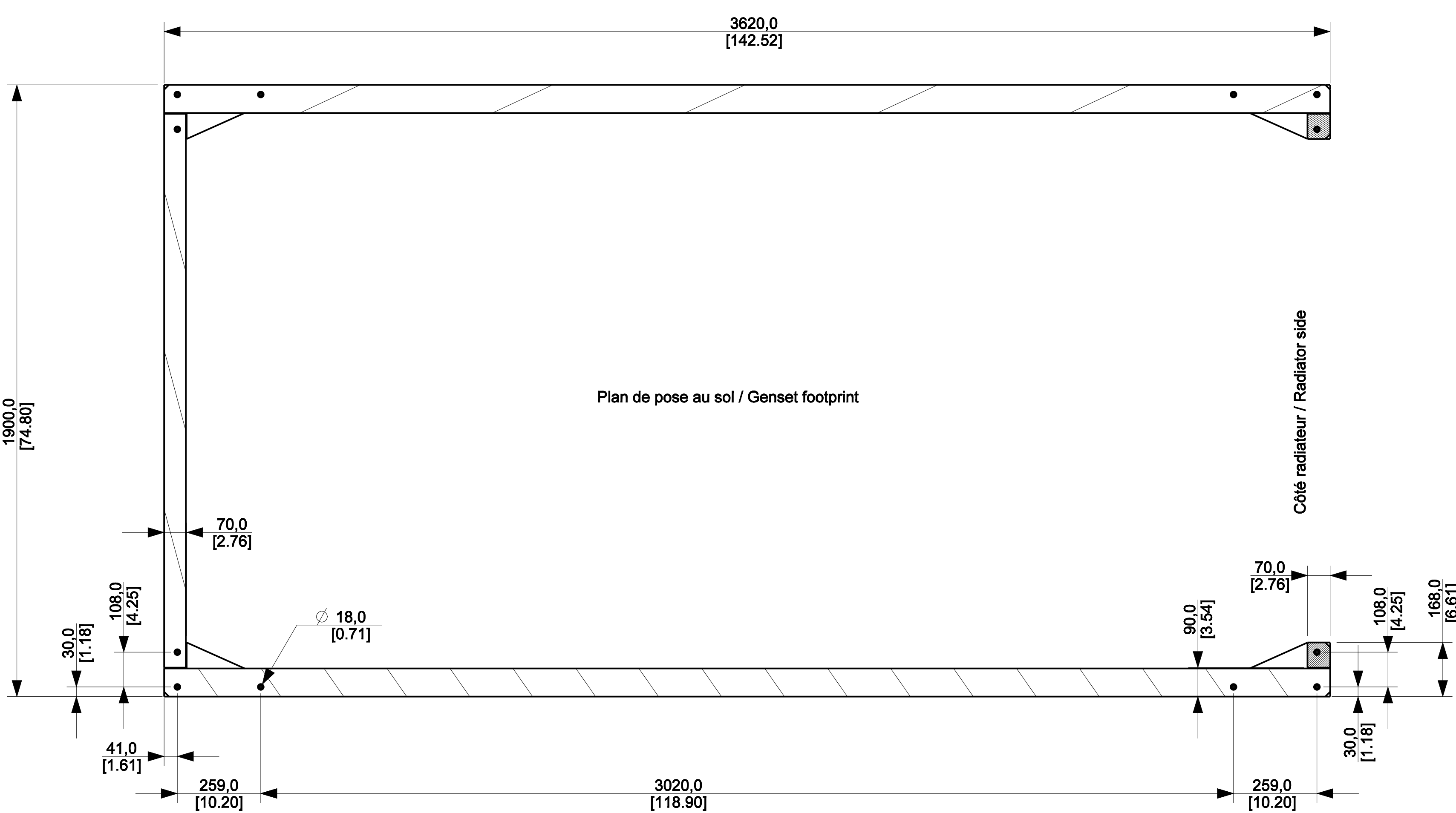
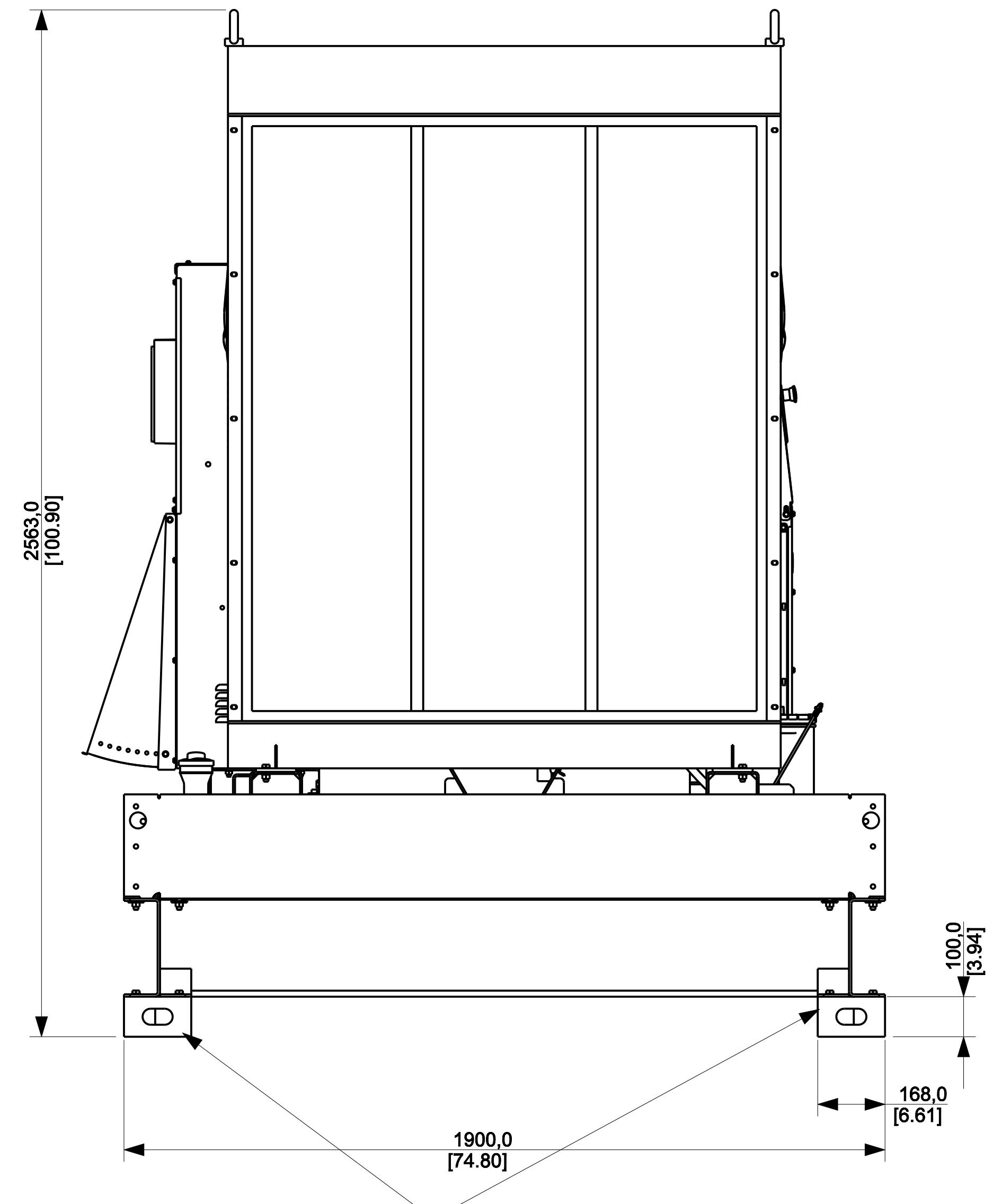
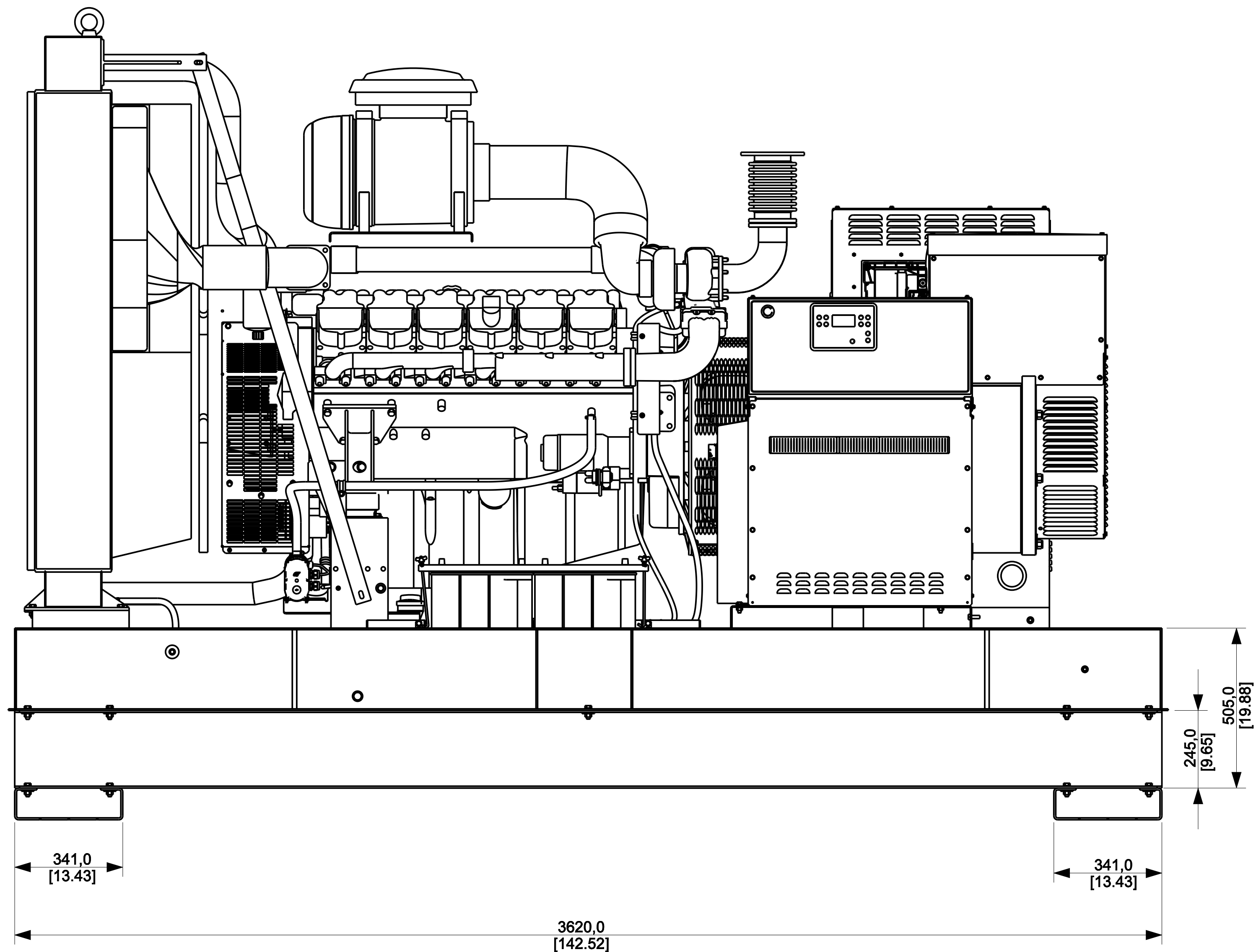

Eléments de manutention uniquement pour le transport à démonter pour l'installation du groupe électrogène
Handling devices only for transportation must be unfitted to install the generator set

REV	DATE	ON COMPOSITE DWGS, SEE PART NO. FOR REVISION LEVEL	BY	DO NOT SCALE, REFERENCE THE MODEL FOR ALL UNSPECIFIED DIMENSIONS
-	02/06/22	NEW DRAWING	SP	UNLESS OTHERWISE SPECIFIED: 1) DIMENSIONS ARE IN MILLIMETERS 2) TOLERANCES ARE: NF ISO 1326-A-1
				<p>KOHLER 270 rue de Koenigsm - 29490 Guipavas CS 4007 - 29011 Saint-Claire B - France</p> <p>THIS DRAWING IS UNDER PROPERTY OF THE COMPANY. IT CANNOT BE PRINTED, USED OR COMMUNICATED WITHOUT ITS AUTHORIZATION.</p> <p>TITLE: 30001545901 SCALE: 1:10 SHEET: 3 of 3</p> <p>APPROVALS: P. SIMON DATE: 01-Jun-22 CAD NO.: 30001545901 REV.: - SIZE: A0</p> <p>DWG NO.: 30001545901</p>