

KDI 1903M KDI 2504M

WORKSHOP MANUAL



KOHLER
IN POWER. SINCE 1920.

REGISTRATION OF MODIFICATIONS TO THE DOCUMENT

Any modifications to this document must be registered by the drafting body, by completing the following table.

Released by	Document code	Revision	Issue date	Review date	Edited by	Endorsed
Technical Documentation	ED0053029610	9.6	04/2013	03/2023	M. SILVESTRONE	V. MANINI

Translated from the original manual in Italian language.

Data reported in this issue can be modified at any time by KOHLER.

1	General information	8
1.1	<i>Useful information</i>	8
1.2	<i>Manufacturer and engine identification</i>	9
1.3	<i>Identification of the main internal components of the engine and operating reference (BASE CONFIGURATION)</i>	10
1.4	<i>Identification of the external components of the engine (BASE CONFIGURATION)</i>	12
2	Technical information	15
2.1	<i>Engine specifications</i>	15
2.2	<i>Engine dimensions (mm)</i>	17
2.3	<i>Performance</i>	18
2.4	<i>Oil</i>	19
2.5	<i>Fuel</i>	20
2.6	<i>Coolant recommendation</i>	22
2.7	<i>Battery recommendations</i>	23
2.8	<i>Periodic maintenance</i>	23
2.9	<i>Fuel system</i>	25
2.10	<i>Lubrication circuit</i>	29
2.11	<i>Coolant circuit</i>	32
2.12	<i>Intake and exhaust circuit</i>	33
2.13	<i>Electric system</i>	35
2.14	<i>Sensors and switches</i>	38
2.15	<i>Electrical components</i>	40
2.16	<i>Timing system and tappets</i>	44
2.17	<i>Components handling</i>	47
2.18	<i>Balancer device (optional)</i>	48
3	Safety information	49
3.1	<i>Before start-up</i>	49
3.2	<i>Safety precautions</i>	49
3.3	<i>General remarks</i>	49
3.4	<i>Safety signal description</i>	52
3.5	<i>Information and safety signals</i>	53
3.6	<i>Safety and environmental impact</i>	55
3.7	<i>Location of safety signals on engine</i>	55
4	Storage information	56
4.1	<i>Product preservation</i>	56
4.2	<i>Engine storage (up to 6 months)</i>	56
4.3	<i>Engine storage (over 6 months)</i>	56
4.4	<i>Engine starting after storage</i>	57

5	Information regarding discharge of liquids	58
5.1	<i>Coolant</i>	58
5.2	<i>Engine oil.....</i>	59
6	Information for replacing the functional units	60
6.1	<i>Injectors and injection pump replacement.....</i>	60
6.2	<i>Coolant pump replacement.....</i>	68
6.3	<i>Replace the crankshaft pulley.....</i>	69
6.4	<i>Oil pump replacement.....</i>	70
6.5	<i>Oil pressure valve replacement.....</i>	73
6.6	<i>Oil filter replacement.....</i>	74
6.7	<i>Fuel filter replacement.....</i>	74
7	Information for disassembly	76
7.1	<i>Recommendations for disassembly</i>	76
7.2	<i>Electric components disassembly</i>	76
7.3	<i>Exhaust manifold disassembly.....</i>	78
7.4	<i>Coolant recirculation components disassembly.....</i>	78
7.5	<i>Crankshaft pulley disassembly</i>	79
7.6	<i>Lubrication circuit disassembly</i>	79
7.7	<i>Intake manifold disassembly.....</i>	81
7.8	<i>Fuel system disassembly.....</i>	81
7.9	<i>Timing system gear disassembly.....</i>	84
7.10	<i>Flange unit disassembly</i>	84
7.11	<i>Cylinder head unit disassembly</i>	85
7.12	<i>Oil sump unit disassembly.....</i>	88
7.13	<i>Engine block disassembly</i>	88
8	Information about overhauling	94
8.1	<i>Recommendations for overhauls and tuning</i>	94
8.2	<i>Crankcase.....</i>	94
8.3	<i>Tappets and tappet housings.....</i>	99
8.4	<i>Crankshaft.....</i>	100
8.5	<i>Connecting rod - piston assembly.....</i>	101
8.6	<i>Cylinder head</i>	105
8.7	<i>Oil pump check</i>	108
9	Assembly information	110
9.1	<i>Information on engine configuration.....</i>	110
9.2	<i>Assembly recommendations</i>	110
9.3	<i>Engine block assembly</i>	111
9.4	<i>Oil sump unit assembly.....</i>	117
9.5	<i>Flange unit assembly</i>	119

9.6	<i>Timing system gear assembly and injection pump</i>	120
9.7	<i>Cylinder head unit assembly</i>	122
9.8	<i>Fuel system assembly</i>	128
9.9	<i>Intake manifold assembly</i>	130
9.10	<i>Exhaust manifold assembly</i>	131
9.11	<i>Lubrication circuit assembly</i>	131
9.12	<i>Crankshaft pulley assembly</i>	133
9.13	<i>Coolant circuit assembly</i>	134
9.14	<i>Electric component assembly</i>	134
9.15	<i>Tightening torques and the use of sealants</i>	136
10	Fluids filling information	142
10.1	<i>Engine oil</i>	142
10.2	<i>Coolant</i>	142
11	Information about optional components	145
11.1	<i>Oil dipstick in cylinder head</i>	145
11.2	<i>Heater (replacement)</i>	146
11.3	<i>Poly-V alternator belt (replacement and adjustment)</i>	147
11.4	<i>Tightening pulley and alternator for Poly-V belt</i>	148
11.5	<i>Idler gear (for 3rd / 4th PTO)</i>	151
11.6	<i>3rd PTO (replacement)</i>	152
11.7	<i>4th PTO (replacement)</i>	155
11.8	<i>3rd + 4th PTO (configurations)</i>	158
11.9	<i>Balancer device (replacement)</i>	158
11.10	<i>Air filter (cartridge replacement)</i>	162
11.11	<i>Remote oil filter (disassembly and assembly)</i>	162
11.12	<i>Intake circuit (replacement)</i>	164
11.13	<i>Muffler (replacement)</i>	165
11.14	<i>Cooling circuit (replacement)</i>	166
11.15	<i>Engine feet (information)</i>	169
11.16	<i>Oil sump with supporting structure</i>	170
11.17	<i>Oil sump 15L</i>	173
11.18	<i>Crankcase oil filter - Lengthwise assembly</i>	175
12	Information on adjustments	177
12.1	<i>Air filter check</i>	177
12.2	<i>Rubber hose and manifold control</i>	177
12.3	<i>Oil leak check</i>	178
12.4	<i>Oil pressure check</i>	178
13	Tools information	180
13.1	<i>Information regarding specific tools</i>	180

14	Information about failures	182
14.1	<i>Possible causes and trouble shooting</i>	182
15	Glossary	184
15.1	<i>Glossary</i>	184

1 GENERAL INFORMATION

1.1 Useful information

- This manual contains the instructions needed to carry out proper use and maintenance of the engine, therefore it must always be available, for future reference when required.
- The information, descriptions and illustrations contained in this manual reflect the basic configuration of the engines (**Par. 1.3** and **Par. 1.4**).
- However, the development of engines is continuous. Therefore, the information in this manual is subject to change without notice.
- **KOHLER** reserves the right to make, at any time, changes on the engines for technical or commercial reasons.
- These changes do not require **KOHLER** to intervene on the production marketed up to that time and nor to consider this manual as inappropriate.

The paragraphs, tables and figures are numbered by chapter and followed by the progressive paragraph, table and/or figure number.

Es: **Par. 1.3** - chapter 1 paragraph 3.

Tab. 2.4 - chapter 2 table 4.

Fig. 4.5 - chapter 4 figure 5.

NOTE: The paragraphs may contain sub-paragraphs.

- All technical terms, specific components and symbols (**Tab. 15.1**) that are in the manual are listed and described inside the glossary, which can be consulted in (**Chap. 15**).
- The references of the objects described in the text and in the figure are indicated by letters and numbers, which are always and only related to the paragraph you are reading unless there are specific references to other figures or paragraphs.
- Reference to values are indicated by letters or numbers (**underlined**).
- Any additional section that **KOHLER** will deem necessary to supply at a later stage must be kept with the manual and considered as an integral part of it.
- The information contained in this manual is the sole property of **KOHLER**, therefore no partial or total reproduction or replication is allowed without the express permission of **KOHLER**.

1.1.1 Useful Information - accident prevention - environmental impact

- Before proceeding repair - handling the engine, you should read **Chap. 3** in its entirety, which contains important information regarding procedures to follow with regard to safety and the environment.

1.2 Manufacturer and engine identification

The engine identification name plate is situated in the lower part of the crankcase; it is visible from the intake or exhaust side.

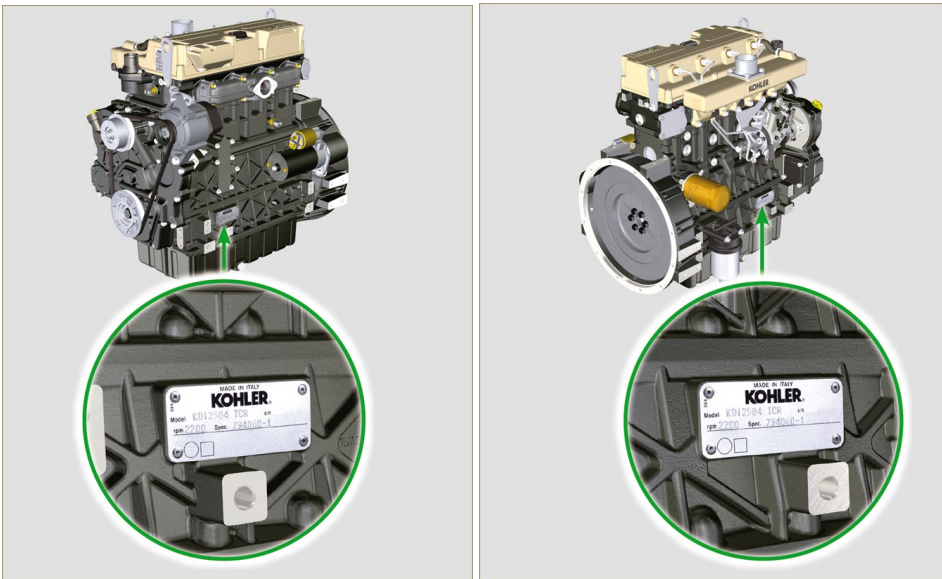


Fig 1.1 - Fig 1.2

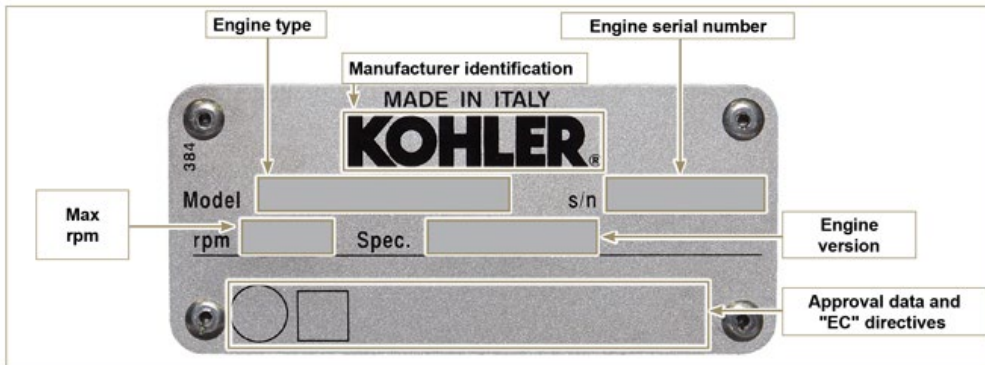


Fig 1.3

1.3 Identification of the main internal components of the engine and operating reference (BASE CONFIGURATION)

VIEW OF EXHAUST SIDE

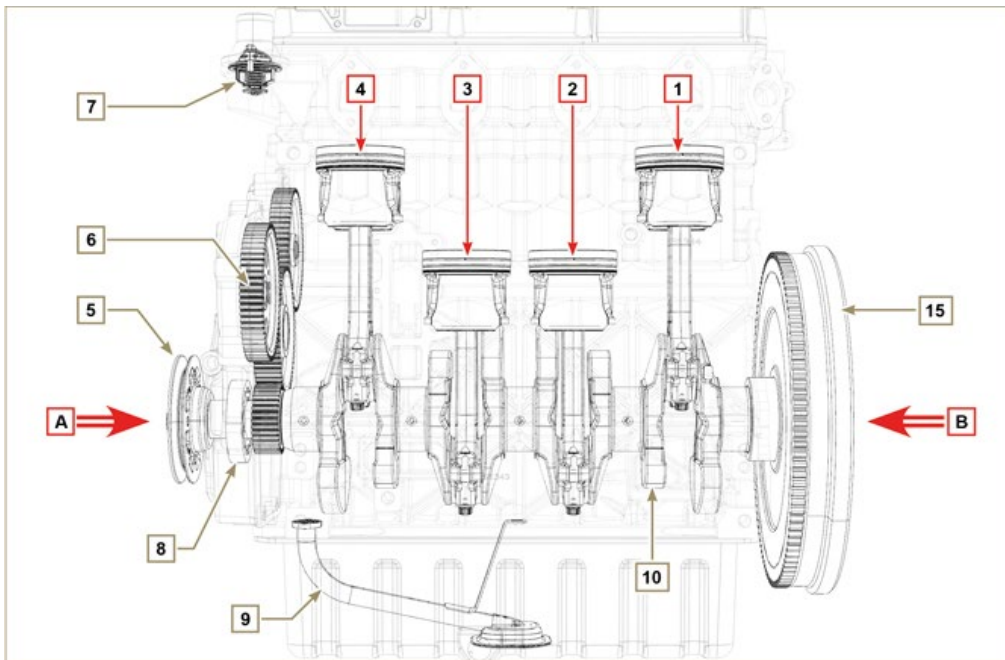


Fig 1.4

The following chapters contain operating references in order to clearly understand the engine. This paragraph illustrates these references that may be recognised by means of some main internal components.

Should you need to execute complex operations, always consult this paragraph.

NOTE: it is advisable to keep this page visible during disassembly and assembly operations.

Tab 1.1

REF.	DESCRIPTION
A ➡	View of timing system side (2 nd PTO)
B ➡	View of flywheel side (1 st PTO)
C ➡	View of exhaust side
D ➡	View of intake side
1	Cylinder/Piston N. 1 (KDI 1903 - KDI 2504)
2	Cylinder/Piston N. 2 (KDI 1903 - KDI 2504)
3	Cylinder/Piston N. 3 (KDI 1903 - KDI 2504)
4	Cylinder/Piston N. 4 (KDI 2504)
POS.	DESCRIPTION
5	Crankshaft pulley (2 nd PTO)
6	Gear timing system
7	Thermostatic valve
8	Oil pump
9	Oil suction hose
10	Crankshaft
11	Exhaust manifold
12	Intake manifold

13	Camshaft
14	Gears adaptor for 3 ^a / 4 ^a PTO (optional)
15	Flywheel (1 st PTO)
16	Injector

VIEW OF FLYWHEEL SIDE

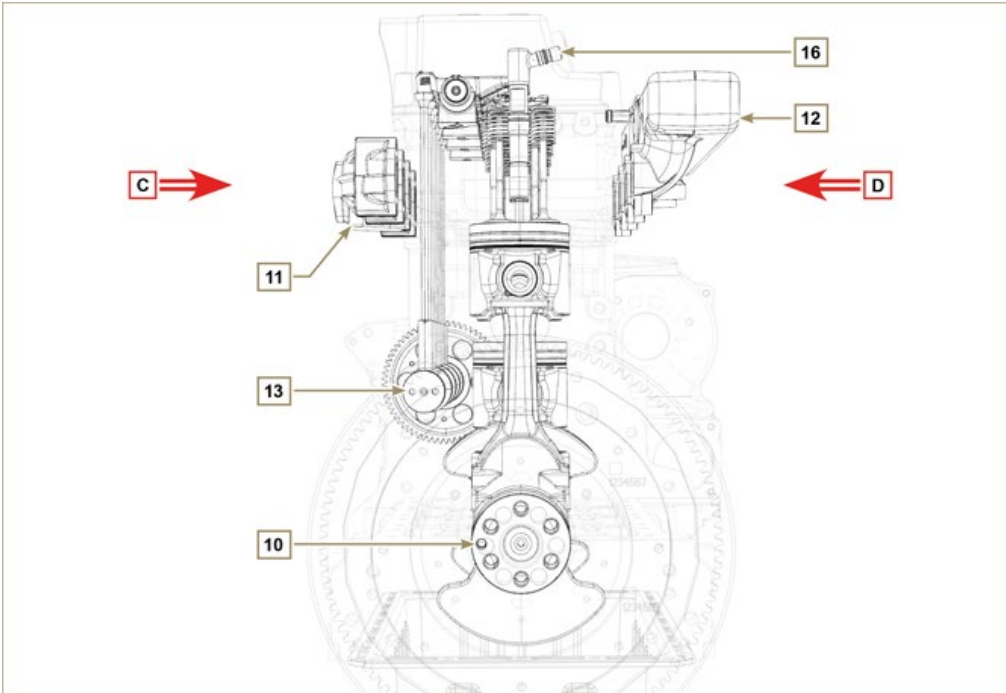


Fig 1.5

VIEW OF TIMING SYSTEM SIDE

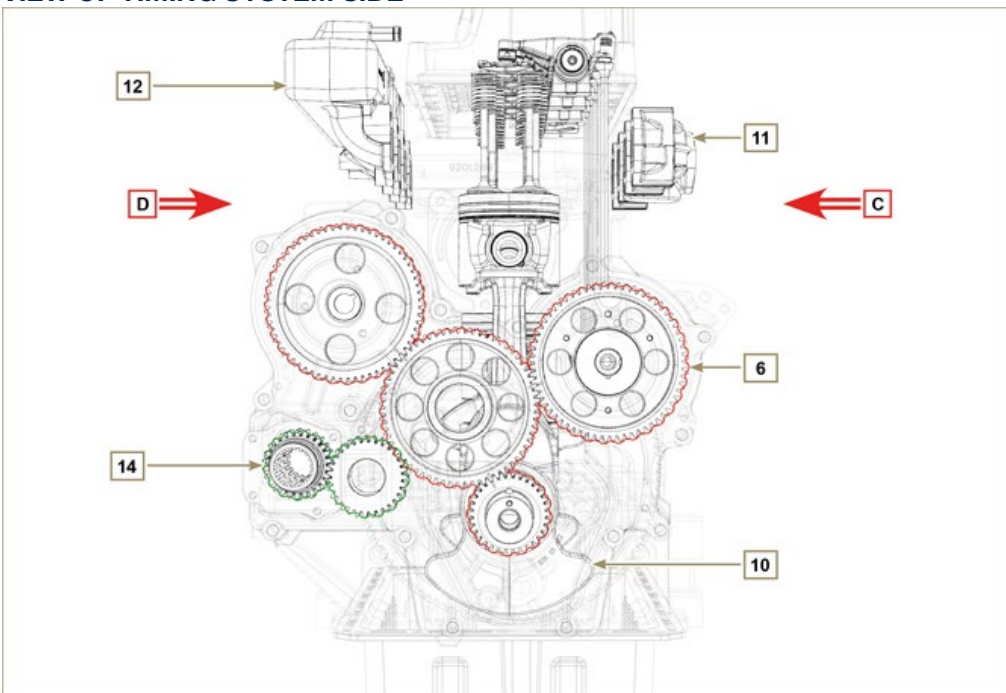


Fig 1.6

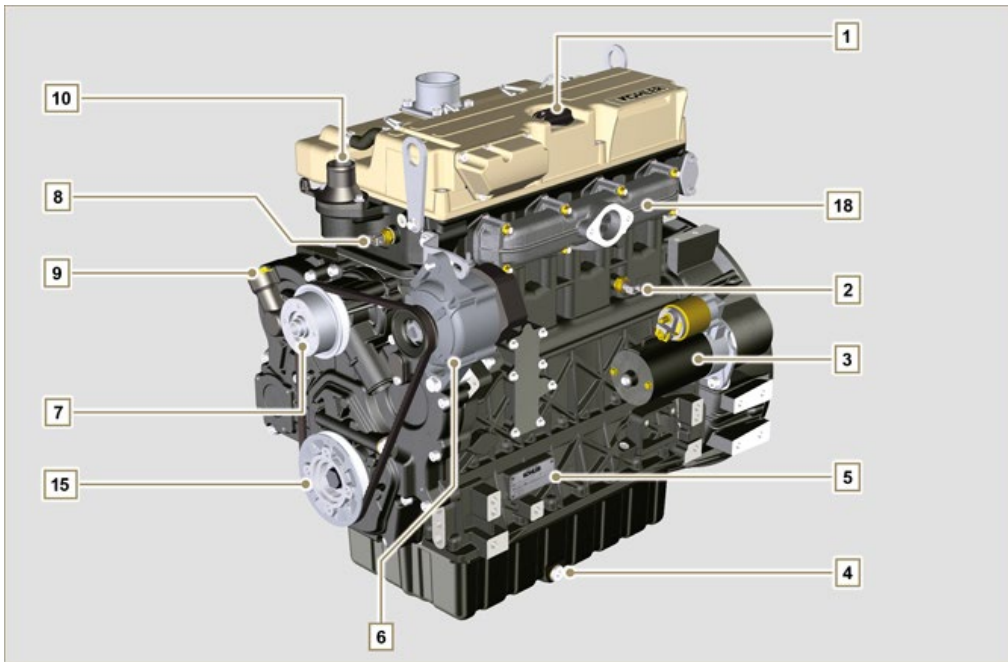
1.4 Identification of the external components of the engine (BASE CONFIGURATION)**VIEW OF TIMING SYSTEM SIDE - EXHAUST**

Fig 1.7

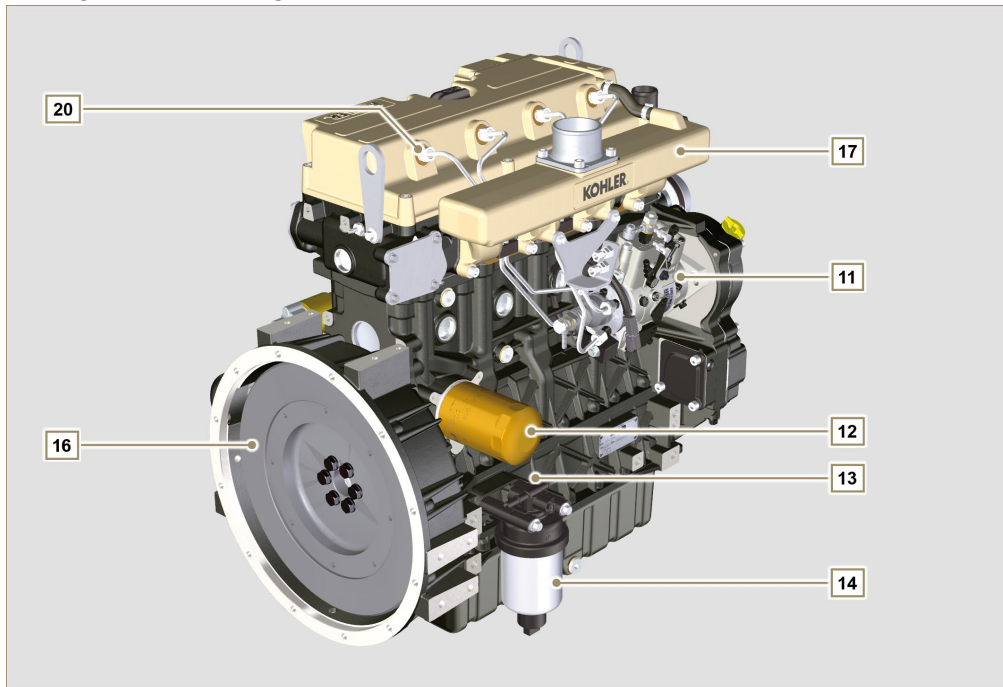
VIEW OF FLYWHEEL SIDE

Fig 1.8

This paragraph illustrates all external components that are present in the base configuration of the engine.

For components present on engines that differ from those represented in these illustrations, refer to [Chap. 11](#).

NOTE: The illustrated components may differ from those illustrated; the illustration is only as an example.

Tab 1.2

POS.	DESCRIPTION
1	Oil filler cap
2	Oil pressure switch
3	Starter motor
4	Oil drain plug
5	Engine identification name plate
6	Alternator
7	Coolant pump
8	Coolant temperature sensor
9	Oil filler cap side
10	Thermostatic valve
11	High-pressure fuel injection pump
12	Lub. oil filter
13	Oil dipstick
14	Fuel filter
15	Crankshaft pulley (2 nd PTO)
16	Flywheel (1 st PTO)
17	Intake manifold

POS.	DESCRIPTION
18	Exhaust manifold
19	Flange bell
20	Injectors

UPPER VIEW

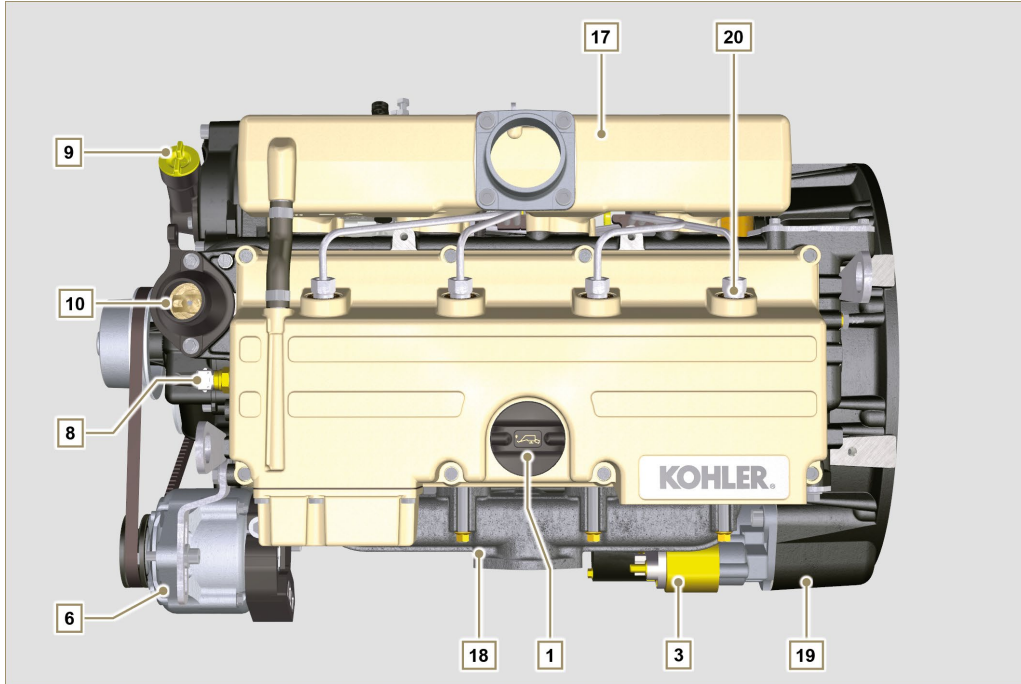


Fig 1.9

2 TECHNICAL INFORMATION

2.1 Engine specifications

MANUFACTURER SPECIFICATIONS AND OPERATION			
GENERAL INFORMATION	UNIT OF MEASURE	KDI 1903 M	KDI 2504 M
Operating cycle		diesel - 4 stroke	
Cylinders	N°	3	4
Bore x stroke	mm	88x102	
Displacement	cm ³	1861	2482
Compression ratio		18.4:1	
Intake		Atmospheric pressure	
Cooling		Liquid	
Crankshaft rotation (view from flywheel side)		Counterclockwise	
Combustion sequence		1-3-2	1-3-4-2
Timing System			
Valves per cylinder	N°	4	
Timing System		Rods and rocker arms - Camshaft in the crankcase	
Tappets		Hydraulic	
Injection		Direct	
Engine dry weight	Kg	210	244
MAX inclination 30' continuous operation	(min./a)	25°	
MAX inclination 1' continuous operation	(min./a)	35°	
Volume of aspirated air (2600 rpm)	Kg/h	2.2	2.9
POWER AND TORQUE			
GENERAL INFORMATION	UNIT OF MEASURE	KDI 1903 M	KDI 2504 M
MAX operating speed	Rpm	2600	
MAX operating power (ISO TR 14396 - SAE J1995 - CE 97/68)	kW	31	41
Maximum torque (at 1500 rpm)	Nm	133	170
Admissible axial load on crankshaft	Kg	300	
CONSUMPTIONS			
GENERAL INFORMATION	UNIT OF MEASURE	KDI 1903 M	KDI 2504 M
Specific fuel consumption (best point)	g/kWh	210	
Oil consumption	%Fuel	< 0.05	
FUEL SUPPLY SYSTEM			
GENERAL INFORMATION	UNIT OF MEASURE	KDI 1903 M	KDI 2504 M

Type of fuel		Diesel UNI-EN590 - ASTM D975	
High-pressure fuel injection pump		STANADYNE - DB	
Fuel supply		Low pressure electric pump	
Fuel filter			
Filtering surface	cm ²	2300	
Degree of filtration	µm	5	
Maximum pressure at injection pump inlet	bar	< 0.5	
LUBRICATION CIRCUIT			
GENERAL INFORMATION	UNIT OF MEASURE	KDI 1903 M	KDI 2504 M
Fuel			
Lubrication		See Par. 2.4	
Circuit forced		Lobe pump	
Oil sump capacity (MAX)	Lt.	8.9	11,5
Oil pressure switch			
Intervention pressure (MIN)	bar	0.8±0.1	
Oil filter			
Maximum operating pressure	bar	7.0	
Degree of filtration	µm	17±2	
Filtering surface	cm ²	1744	
COOLING CIRCUIT			
GENERAL INFORMATION	UNIT OF MEASURE	KDI 1903 M	KDI 2504 M
Coolant	%	See Par. 2.6	
Water pump	Lt./min	75	
Thermostatic valve			
Opening temperature	°C	+79	
Stroke at 91°C	mm	7.50	
Liquid recirculation	Lt./h	9	
ELECTRICAL SYSTEM - ELECTRIC FAN			
GENERAL INFORMATION	UNIT OF MEASURE	KDI 1903 M	KDI 2504 M
Circuit rated voltage	V	12	
External alternator (rated current)	A	80	
Starter motor power	kW	2	
System electrical consumption, excluding: heater, electric pump, electric fan, starter motor	W	24	
Coolant temperature indicator light			
Indicator light operating temperature	°C	+100/+110	

2.2 Engine dimensions (mm)

NOTE: Dimensions vary according to engine configuration.

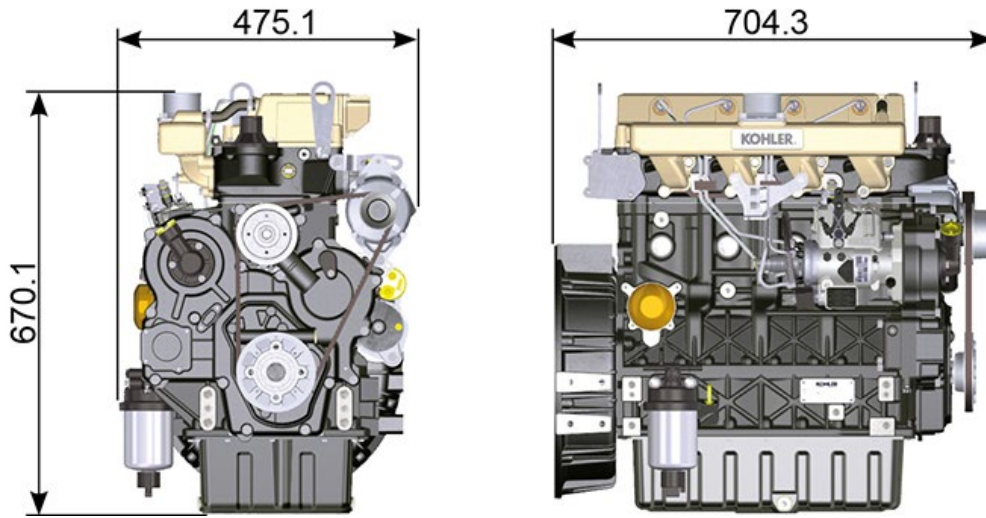


Fig 2.1

2.3 Performance

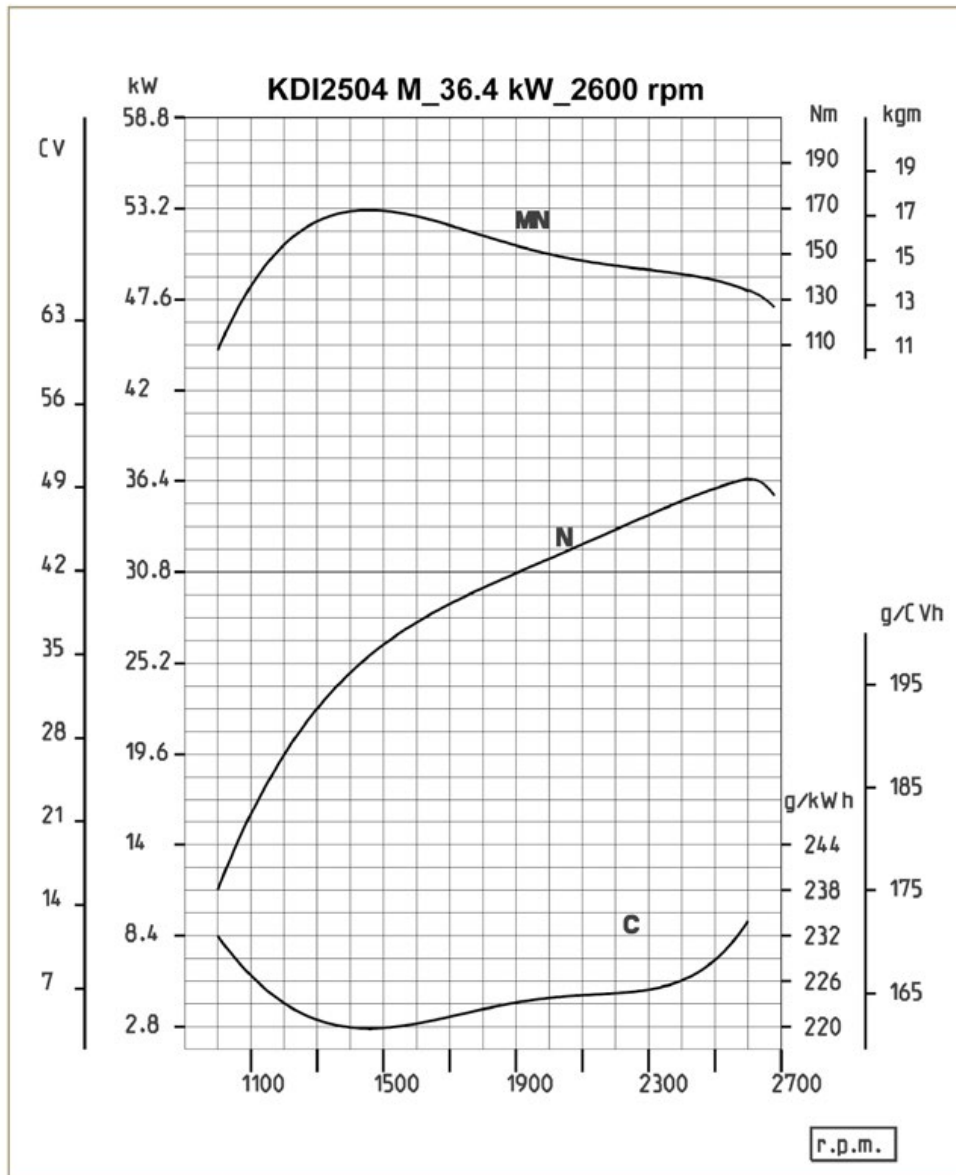


Fig. 2.2

N = Automotive rating curve

MN = Torque curve

C = Specific fuel consumption curve

NOTE: Refer to **KOHLER** for power curves, torque curves and specific consumptions at speeds other than those given above.

Key

- **N (ISO TR 14396 - SAE J1995 - CE 97/68) AUTOMOTIVE RATING CURVE:** Intermittent duty at variable speed and load. Engine capacity at intermittent conditions with variable speed and load.
- **MN: = TORQUE RATING CURVE:** Also called twisting moment, it is the push generated by the engine through transmission. The highest engine performance is obtained at the maximum torque.
- **C = SPECIFIC CONSUMPTION CURVE:** Engine fuel consumption in a given time at a certain revolution value. Expressed in g/kW (grams/kilowatt), it expresses fuel yield.

* The above curves express indicative values, in that the overall performance depends on the type of application and the ECU control uni.

- The ratings reported in the diagram regard the run-in engine, fitted with air and exhaust filters, at the atmospheric pressure of 1 Bar and at a room temperature of +20°C
- Maximum rating is guaranteed with a 5% tolerance.



Warning

- Non approval by **KOHLER** for any modification releases the company from liability for damage incurred on the engine.

2.4 Oil



Important

- The engine may be damaged if operated with improper oil level.
- Do not exceed the **MAX** level because a sudden increase in engine rpm could be caused by its combustion.
- Use only the recommended oil to ensure adequate protection, efficiency and service life of the engine.
- The use of lubricants other than recommended may shorten the engine life.
- Viscosity must be appropriate to the ambient temperature to which the engine is to be exposed.



Danger

- Prolonged skin contact with the exhausted engine oil can cause cancer of the skin.
- If contact with oil cannot be avoided, thoroughly wash your hands with soap and water as soon as possible.
- For the exhausted oil disposal, refer to the **Par. DISPOSAL and SCRAPPING.**

2.4.1 SAE oil classification

- In the SAE classification, oils are identified according to viscosity without considering any other qualitative characteristic.
- The code is composed of two numbers, which indicate, and must correspond to, the ambient temperature in which the engine operates, the first number refers to the viscosity when cold, for use during winter (" **W** "), while the second number is for viscosity at high temperatures.

RECCOMENDED OIL		
VISCOSITY	SAE	10w-30 (-25°C ÷ +40°C) 10w-40 (-25°C ÷ +50°C) 5w-30 (-30°C ÷ +40°C) 0w-40 (-40°C ÷ +50°C)
	API	CI-4 Plus CI-4 CH-4
WITH SPECIFICATIONS	ACEA	E7 E5

- Low S.A.P.S. oils, sulfate ashes <1% may not be used with fuels with a sulfur content >50ppm.
- Filtration of oils is critical to proper operation and lubrication; always change filters regularly as specified in this manual.

2.5 Fuel



Important

- Use of other types of fuel could damage the engine. Do not use dirty diesel fuel or mixtures of diesel fuel and water since this will cause serious engine faults.
- **Any failures resulting from the use of fuels other than recommended will not be warranted.**



Warning

- Clean fuel prevents the fuel injectors from clogging. Immediately clean up any spillage during refuelling.
- Never store diesel fuel in galvanized containers (i.e. coated with zinc). Diesel fuel and the galvanized coating react chemically to each other, producing flaking that quickly clogs filters or causes fuel pump and/or injector failure.

2.3

FUEL COMPATIBILITY
EN 590 (biodiesel content max. 7% (V/V))
ASTM D 975 Grade 1-D S15
ASTM D 975 Grade 2-D S15
NATO F-54, equivalent to diesel fuel in accordance with EN 590
EN 590 or ASTM D 975 Grade 1, 2 -D S15 Arctic Diesel
JIS K 2204 No. 1, No. 2

NOTE: In a warranty case the customer must prove by a certificate from the fuel supplier that an allowed fuel was used.

KDI Mechanical Injection Tier 3, Tier 4 Final – Stage IIIA, Stage IIIB, Stage V certified Engines (w and w/o EGR)

- Those engines are designed for fuels in accordance with EN 590 and ASTM D975 for a cetane number of at least 45. Since those engines are not equipped with exhaust gas after-treatment, they can be operated with diesel fuels with sulfur content up to 500 mg/kg (ppm). Compliance with the emission requirements is guaranteed only with sulfur content up to 15 mg/kg (ppm). Engines operated with fuels as per EN 590 and ASTM D975 with sulfur content < 15mg/kg have an oil changing interval of 500hrs. Fuels with a sulfur content > 500 mg/kg demand a shorter lubricating oil

change interval. This is set at 250hrs. However, the engine oil must be changed when the Total Base Number TBN is reduced to 6.0 mgKOH/g test method ASTM D4739. With high fuel sulfur content fuel this may happen at 125hrs. Do not use low SAPS oils.

KDI Mechanical Injection Uncertified Engines (no EGR Engines)

- Those engines are designed for fuels in accordance with EN 590 and ASTM D975 for a cetane number of at least 45. Since those engines are not equipped with exhaust gas after-treatment, they can be operated with diesel fuels with sulfur content up to 2000 mg/kg (ppm). Engines operated with fuels as per EN 590 and ASTM D975 with sulfur content < 15mg/kg have an oil changing interval of 500hrs. Fuels with a sulfur content > 500 mg/kg demand a shorter lubricating oil change interval. This is set at 250hrs. However, the engine oil must be changed when the Total Base Number TBN is reduced to 6.0 mgKOH/g test method ASTM D4739

2.5.1 Fuel for low temperatures

- When operating the engine in ambient temperatures lower than 0 degrees C, use suitable low temperature fuel normally available from fuel distributors and corresponding to the specifications of **Tab. 2.3.**
- These fuels reduce the formation of paraffin in diesel at low temperatures.
- When paraffin forms in the diesel, the fuel filter becomes blocked interrupting the flow of fuel.

2.5.2 Biodiesel fuel

- Fuels containing 10% methyl ester or B10, are suitable for use in this engine provided that they meet the specifications listed in the Tab. 2.3.
- **DO NOT USE** vegetable oil as a biofuel for this engine.

2.4

BIODIESEL COMPATIBILITY

Biodiesel according to EN 14214 (only permissible for mixture with diesel fuel at max. 10% (V/V))

US biodiesel according to ASTM D6751 – 09a (B100) (only permissible for mixtures with diesel fuel at 10% (V/V))

2.5.3 Synthetic fuels: GTL, CTL, BTL, HV

It is a well-known fact that engines which are operated for longer periods with conventional diesel fuel and then converted to synthetic fuels suffer shrinkage of polymer seals in the injection system and thus fuel leaks. The reason for this behavior is that the aromatic-free synthetic fuels can lead to a change in the sealing behavior of polymer seals.

Therefore, conversion from diesel fuel to synthetic fuel may only be done after changing the critical seals. The problem of shrinkage does not occur when an engine was operated with synthetic fuel from the start.

2.5.4 Non-Road Fuels

Other non-road fuels may be used if they comply with all the limit values of EN 590 except for the fuel density, the cetane number and the sulfur content.

The following limits apply for these parameters:

2.5

FUEL PARAMETER	UNIT	LIMIT VALUE
Cetane number		Min. 49
Fuel density at 15°C	Kg/m ³	820 - 860
Sulfur content	mg/kg or ppm	max. 500

2.5.5 Jet Fuels

Only for KDI Mechanical Injection Uncertified Engines (no EGR Engines).

The following jet fuels can be used but only adopting an additional fuel filter with lubricity doser:

2.6

FUEL	
F-34/F-35 (kerosene, NATO designation)	JP-8 (kerosene, US military designation)
F-44 (kerosene, NATO designation)	JP-5 (kerosene, US military designation)
F-63 (kerosene, NATO designation, equivalent to F-34/F-35 with additives)	Jet A (kerosene for civil aviation)
F-65 (kerosene, NATO designation, 1:1 mixture of F-54 and F-34/F-35)	Jet A1 (kerosene for civil aviation)

2.5.6 Emission-Related Installation Instructions Failing to follow the instructions in the applications guidebook when installing a certified engine in a piece of nonroad equipment violates federal law (40 CFR 1068.105(b)), subject to fines or other penalties as described in the Clean Air Act.

OEM must apply a separate label with the following statement: "ULTRA LOW SULFUR FUEL ONLY" near the fuel inlet.

Ensure you are installing an engine appropriately certified for your application. Constant speed engines may only be installed on constant speed equipment for constant speed operation.

If you install the engine in a way that makes the engine's emission control information label hard to read during normal engine maintenance, you must place a duplicate label on the equipment, as described in 40 CFR 1068.105.

2.6 Coolant recommendation

A mixture of 50% demineralized water and 50% low silicate ethylene glycol based coolant liquid must be used. Use a Long Life or Extended Life Heavy Duty OAT coolant free of: silicates, phosphates, borates, nitrites and amines.

The following ethylene-glycol based engine coolant for all models within KDI engine family may be used:

- OAT (Organic Acid Technology) Low Silicate: **ASTM D-3306 D-6210**
- HOAT (Hybrid Organic Acid Technology) Low Silicate: **ASTM D-3306 D-6210**

The above coolants in concentrated formulation must be mixed with distilled, deionized, or demineralized water. A pre-mixed formulation (40-60% or 50-50%) can be used directly when available.



Important

- Do not mix ethylene glycol and propylene glycol based coolants. Do not mix OAT and HOAT based coolant. OAT performance life can be drastically reduced if contaminated with nitrite-containing coolants.
- Never use automotive-type coolants. These coolants do not contain the correct additives to protect heavy – duty diesel engines.

OAT coolants are maintenance free up to 6 years or 6000hrs of operation, provided that the cooling system is topped up using the same type of coolant. Do not mix different coolant types. Test the coolant condition annually with coolant test strips.

HOAT are not all maintenance free and it is recommended to have SCA (Supplemental Coolant Additives) added at the first maintenance interval.

2.7 Battery recommendations

Battery not supplied by Kohler

Tab. 2.7

RECOMMENDED BATTERIES	
AMBIENT TEMPERATURE	BATTERY TYPE
> - 15°C	12V 100 Ah - 800 CCA/SAE
-15°C ÷ -25°C	12V 110 Ah - 950 CCA/SAE
< - 25°C	12V 120 Ah - 1000 CCA/SAE

2.8 Periodic maintenance

The intervals of preventive maintenance in **Tab. 2.8**, **Tab. 2.9**, **Tab. 2.10** and **Tab. 2.11** refer to the engine operating under normal operating conditions with fuel and oil meeting the recommended specifications.

2.8

CLEANING AND CHECKING				
OPERATION DESCRIPTION	PERIOD (HOURS)			
	100	250	500	5000
Engine oil level ⁽⁸⁾	■			
Coolant level ^{(8) (9)}	■			
Water presence in fuel filter	■			
Cartridge dry-type air filter ⁽²⁾	■			
Radiator heat-exchange surface ^{(2) (8)}		■		
Alternator belt ⁽⁸⁾		■		
Rubber hose (intake air / coolant)			■	
Fuel hose			■	
Starter Motor				■
Alternator				■

2.9

REPLACEMENT		
OPERATION DESCRIPTION	PERIOD (HOURS)	
	500	5000
Alternator belt ⁽³⁾	■	
Cartridge dry-type air filter ⁽²⁾	■	
Intake manifold hose (air filter - intake manifold) ⁽⁷⁾		■
Coolant hoses ⁽⁷⁾		■

Fuel line hose ⁽⁷⁾			
Coolant	OAT		
	HOAT ⁽¹⁰⁾		

2.10

ENGINE OIL AND OIL FILTER CARTRIDGE REPLACEMENT

ENGINE VERSION	PERIOD (HOURS)	
	250	500
KDI Mechanical Injection Stage V ⁽¹⁾		
KDI Mechanical Injection Tier 4 Final – Stage IIIB ⁽¹⁾		
KDI Mechanical Injection Tier 3 – Stage IIIA ⁽¹⁾		
KDI Mechanical Injection Uncertified Engines ⁽¹⁾⁽¹¹⁾		

2.11

FUEL FILTER AND PREFILTER CARTRIDGE REPLACEMENT

ENGINE VERSION	PERIOD (HOURS)	
	250	500
KDI Mechanical Injection Stage V ⁽¹⁾		
KDI Mechanical Injection Tier 4 Final – Stage IIIB ⁽¹⁾		
KDI Mechanical Injection Tier 3 – Stage IIIA ⁽¹⁾		
KDI Mechanical Injection Uncertified Engines ⁽¹⁾		

(1) - In case of low use: 12 months.

(2) - The period of time that must elapse before checking the filter element depends on the environment in which the engine operates. The air filter must be cleaned and replaced more frequently under very dusty conditions.

(3) - In case of low use: 36 months.

(7) - The replacement interval is only an indication, it strongly depends from environmental condition and hose status detected during regular visual inspection.

(8) - The first check must be done after 10 hours.

(9) - Test the coolant condition annually with coolant test strips.

(10) - It is recommended to have SCA (Supplemental Coolant Additives) added at the first maintenance interval.

(11) - Read Cap. 2.5, "***KDI Mechanical Injection Uncertified Engines (no EGR Engines)***"

2.9 Fuel system

2.9.1 Supply system



Important

- The high pressure supply injection system is highly susceptible to damage if the fuel is contaminated.
- It is crucial that all components of the injection circuit are thoroughly cleaned before the components are removed.
- Thoroughly wash and clean the engine before maintenance.
- Contamination in the fuel supply injection system may cause a reduction in effectiveness / operation of engine fault indication.
- If the engine is cleaned with high pressure washer, then the nozzle must be kept at a minimum distance of 200mm from the surface, and not directed at electrical components and connectors.

The fuel supply system is under low pressure from the tank **1** to the high-pressure fuel injection pump **5**.

NOTE: The representation of fuel tank is purely indicative. Component not necessarily supplied by **KOHLER**.

Tab 2.12

POS.	DESCRIPTION
1	Fuel tank
2	Fuel supply hose from the tank to the injection pump
3	Fuel filter
4	Electrical fuel feed pump
5	Injection pump
6	Injector high-pressure hose from the injection pump to the injectors
7	Injectors

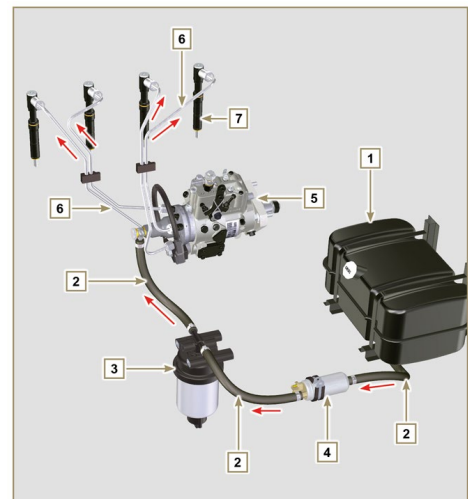


Fig 2.4

2.9.2 Fuel return circuit

The fuel return circuit is under low pressure.

NOTE: The representation of fuel tank is purely indicative. Component not necessarily supplied by **KOHLER**.

Tab 2.13

POS.	DESCRIPTION
1	Injectors
2	Injectors fuel return pipe
3	Injection pump

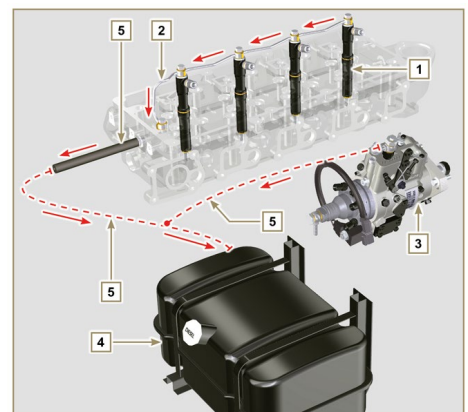


Fig 2.5

4	Fuel tank
5	Fuel return pipe to the tank

2.9.3 Injection pump

Pressure into the injection pump must be positive in all operating conditions.

The injection pump is operated by means of the pump control gear and sends high-pressure fuel to the injectors.

NOTE: In the event of leakage from the high pressure circuit do not intervene with the engine running, but turn it off and wait 5 - 10 minutes before checking the leak.

Tab 2.14

POS.	COMPONENTS DESCRIPTION
1	Accelerator lever
2	Min Adjustment
3	Max Adjustment
4	Torque adjustment
5	High pressure delivery to injectors
6	Return to fuel tank
7	Inlet suction fuel
8	Cold starting device
9	Gasket
10	Shaft
11	Advance settings (locked)
12	Pump identification label
13	Air bleeding screw
14	Pump control shaft blocking device.

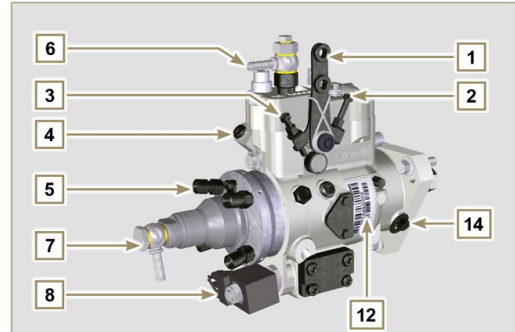


Fig 2.6

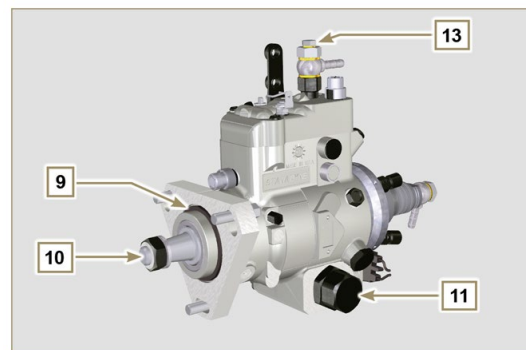


Fig 2.7

2.9.4 Injector

It is a device used to introduce fuel, in the form of one or more jets that are adequately pulverised and suitably oriented directly into the combustion chamber. They consist of a metallic body that internally provides a mobile element that acts on the needle: this, rising against the action of a calibrated spring, allows the release of fuel under high pressure.

Opening pressure: 260-268 bar (3770-3886 PSI)



Important

- The injectors are calibrated individually.
- Fuel contamination causes serious damage to the injection system.

Tab 2.15

POS.	COMPONENTS DESCRIPTION
1	Inlet fuel
2	Gasket
3	Gasket
4	Nozzle
5	Hole for fuel return to fuel tank

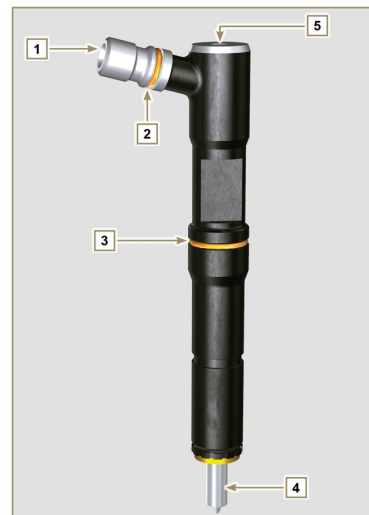


Fig 2.8

2.9.5 Fuel filter

The fuel filter is situated on the crankcase of the engine or it may be assembled on the frame of the vehicle.

Tab 2.16

POS.	COMPONENTS DESCRIPTION
1	Fuel filter support cartridge
2	Air bleeding screw
3	Cartridge
4	Water in fuel sensor
5	Hole water drainage

Tab 2.17 Cartridge characteristics

DESCRIPTION	VALUE
Filtering surface	2.300 cm ²
Degree of filtration	5 µm
Max operating pressure	2.0 Bar

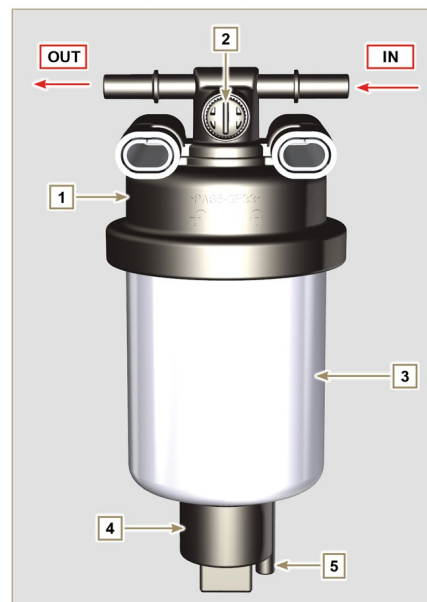


Fig 2.9

2.9.6 Electric fuel pump (optional)

When the electric fuel pump is installed in a diesel engine, one must:

1. Remove any filters installed on the inlet of the electric fuel pump;
2. Insert a pre-filter between the tank and the electric pump;
3. The electric pump must be installed on the application at a height from the minimum tank level such as to generate a **MAX.** pressure drop equal to a column of 500 mm of fuel;
4. Insert a shut-off valve to prevent dry operation due to the emptying of the intake manifold;
5. The electric pump must guarantee a supply pressure at the inlet positive in all conditions.

Tab 2.18

POS.	DESCRIPTION
1	Fuel tank
2	Arrival pipe from the tank
3	Prefilter
4	Flow pipe from pre-filter to electric pump
5	Electric pump
6	Flow pipe to the fuel filter
7	Fuel filter

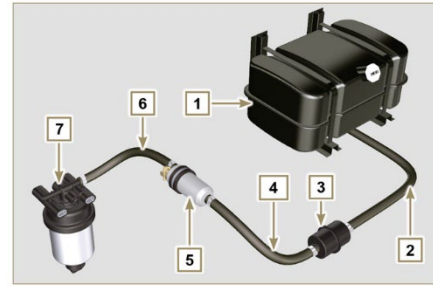


Fig 2.10

2.9.7 Guards for fuel injection circuit components

High-pressure injection circuit components are particularly sensitive to impurities.

To prevent impurities, even microscopic ones, from accessing the fuel input or output unions, you are required to close these accesses by means of specific caps as soon as the various tubes are disassembled and disconnected.

Disassembly of any component of the injection circuit must not occur in dusty environments.

Cap guards must remain closed in their housing (**ST_40**) until the moment they are to be used.

Pay special attention when using the caps and avoid any contamination of dust or dirt of any kind.

Even after using the caps illustrated in this paragraph, all components of the injection circuit must be placed with care in environments that are free of any type of impurity.

Fig. 2.11 and 2.12 illustrate the caps that must be used on components of the injection circuit.



Fig 2.11

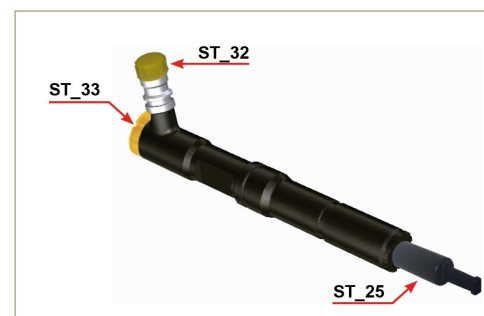


Fig 2.12

Cap guards must be accurately washed after use and placed back in their housing (ST_40).



Important

- It is highly recommended to have this page visible during disassembly operations of the components of the fuel injection circuit.

2.10 Lubrication circuit

2.10.1 Lubrication circuit diagram

The oil pump is driven by the crankshaft on the timing system side.

On the parts of the systems shown in green on In the parts in green, the oil is in intake, in the parts in red, the oil is under pressure and in those in yellow the oil is returning towards the oil sump **2** (not under pressure).

Tab 2.19

COLOUR	DESCRIPTION
Green	Oil in intake
Red	Oil under pressure
Yellow	Oil returning to the oil sump

Tab 2.20

POS.	DESCRIPTION
1	Oil pump rotors
2	Oil sump
3	Crankshaft
4	Camshaft
5	Rocker arm pin
6	Hydraulic tappets
7	Rocker arm cover
8	Cylinder head
9	Upper crankcase
10	Lower crankcase
11	Oil filter
12	PTO 3rd/4th gear housing

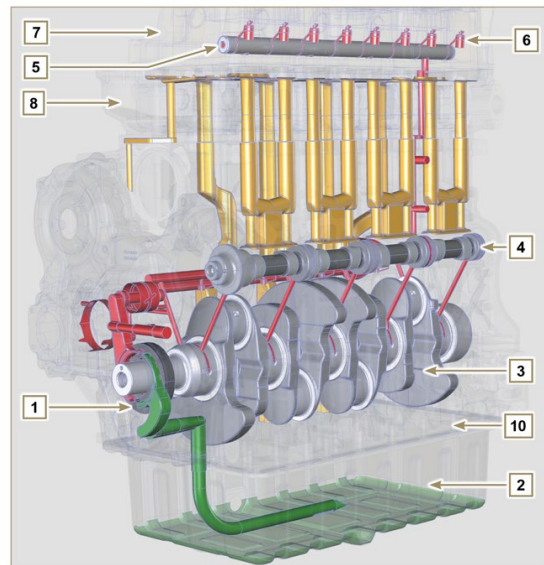


Fig 2.13

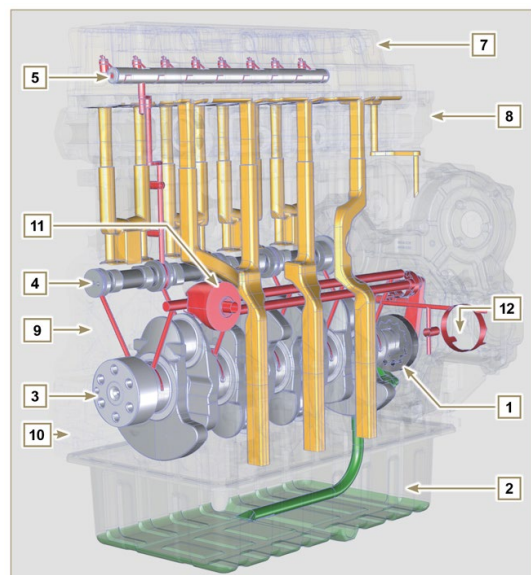


Fig 2.14

NOTE: Click by side to play the procedure.

<https://www.youtube.com/embed/5HuLfSqgz6s?rel=0>

2.10.2 Oil pump

The oil pump rotors are trochoidal (with lobes) and are activated from the crankshaft by means of the key. The pump body is situated inside the distribution guard.

It is imperative to assemble the rotors with reference **A** visible by the operator.

Tab 2.21

POS.	DESCRIPTION
1	Internal rotor
2	External rotor
3	Oil pump crankcase
4	Pump control key
5	Timing system crankcase
6	Crankshaft

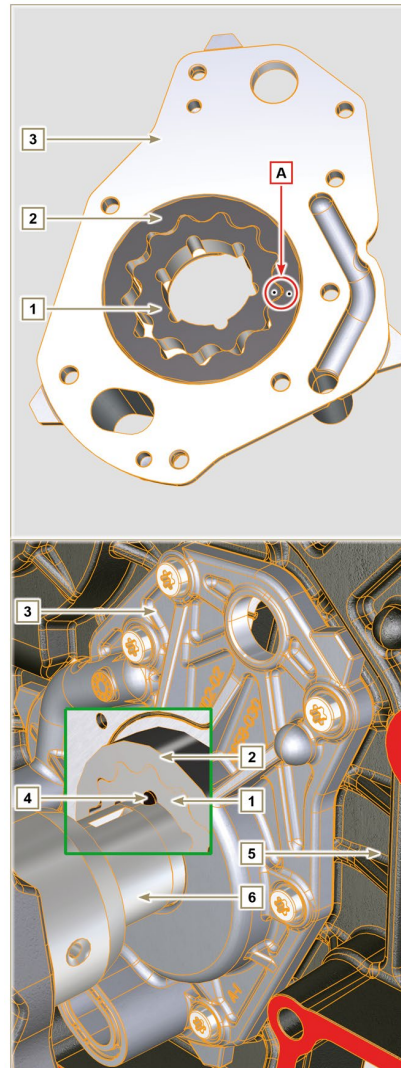


Fig 2.15

2.10.3 Oil filter

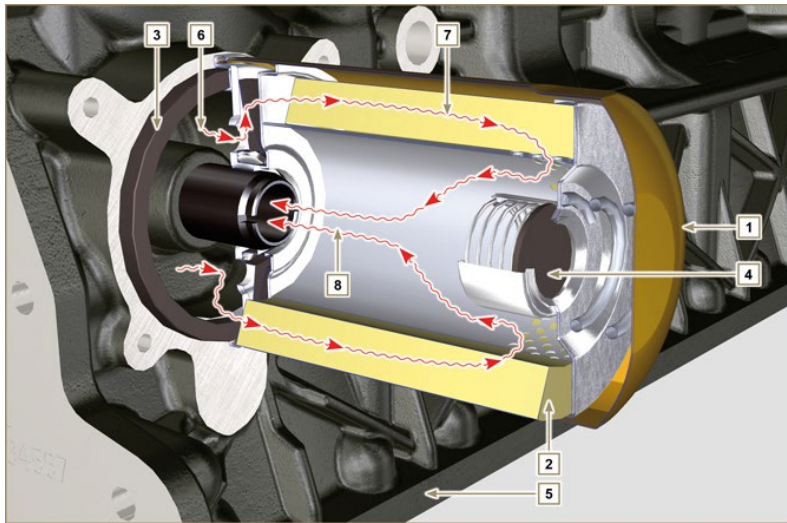


Fig 2.16

Tab 2.22

DESCRIPTION	VALUE
Filtering surface	2.000 cm ²
Degree of filtration	15 µm
Max operating pressure	7.0 Bar

Tab 2.23

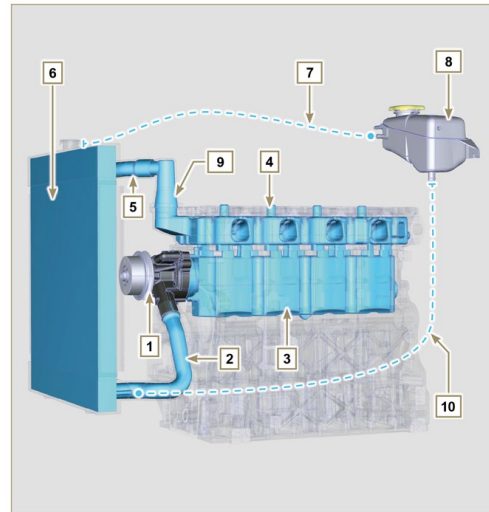
POS.	DESCRIPTION
1	Oil cartridge
2	Filter element
3	Gasket
4	Safety valve
5	Upper crankcase
6	Inlet oil
7	Oil filtering
8	Output oil (sent to the circuit)

2.11 Coolant circuit

2.11.1 Coolant circuit diagram

Tab 2.24

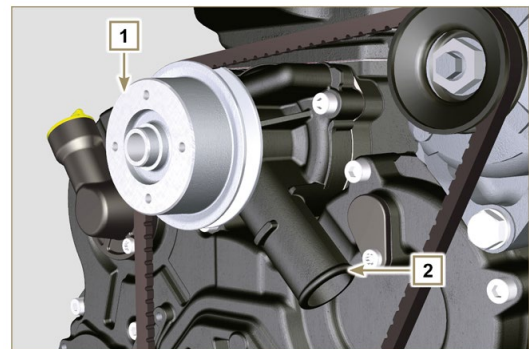
POS.	DESCRIPTION
1	Coolant pump
2	Coolant intake
3	Coolant, cylinder
4	Coolant, cylinder head
5	Coolant to radiator
6	Coolant into radiator
7	Vent line from radiator (to 8)
8	Compensation tank
9	Thermostatic valve
10	Return from compensation tank


Fig 2.17

2.11.2 Coolant pump

Tab 2.25

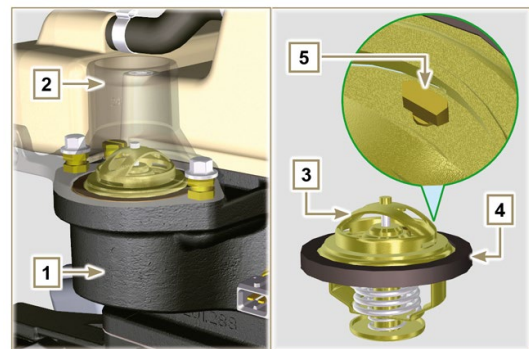
POS.	DESCRIPTION
1	Coolant pump control pulley
2	Coolant intake fitting


Fig 2.18

2.11.3 Thermostatic valve

Tab 2.26

POS.	DESCRIPTION
1	Cylinder head
2	Coolant outlet cover
3	Thermostatic valve
4	Gaskets
5	Air bleeding hole


Fig 2.19

Opening temperature $+79^{\circ} \pm 2^{\circ}\text{C}$.

2.11.4 Radiator (optional)

NOTE: Component not necessarily supplied by Kohler.

Tab 2.27

POS.	DESCRIPTION
1	Radiator group
2	Coolant refill cap
3	Vent tube or excess coolant return
4	Coolant flow manifold
5	Coolant intake manifold
6	Fan
7	Protective grid

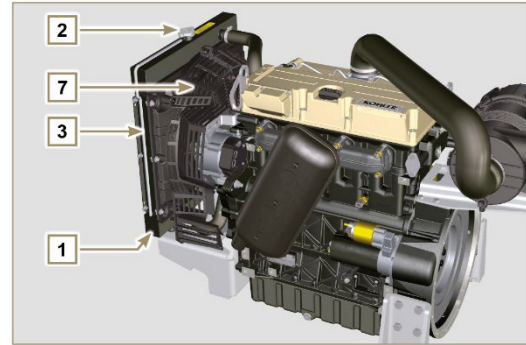


Fig 2.20

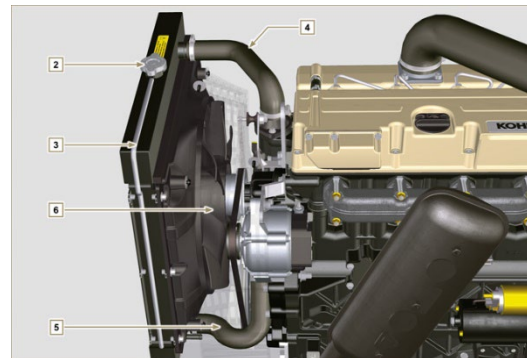


Fig 2.21

2.12 Intake and exhaust circuit

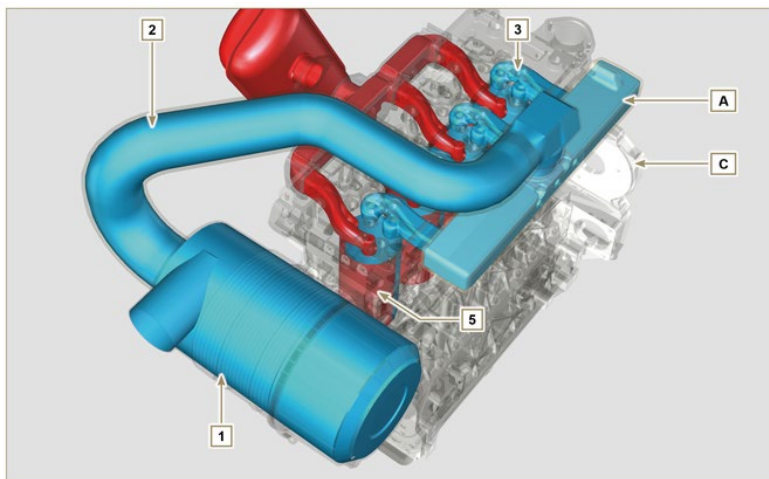


Fig 2.22

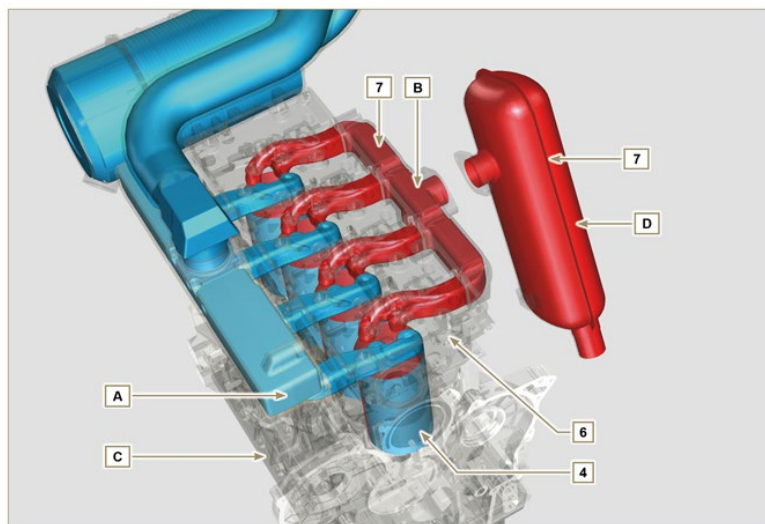


Fig 2.23

**Important**

- The air temperature inside the intake manifold must never exceed that of the environment by 10°C.

Clean air is sucked by means of an intake manifold and via ducts in the cylinder head, enters the cylinders. Compressed air inside the cylinders and mixed with the fuel transforms into Gas after combustion. Gas is expelled from the cylinders and sent to the exhaust manifold, which expels the gas towards the exhaust muffer.

2.12.1 Air filter (optional)

NOTE: Component not necessarily supplied by KOHLER.

**Important**

- The air filter is a dry-type one, with a replaceable paper filter cartridge
- The filter intake must be positioned in a cool area.
- The temperature of the aspirated air must never exceed ambient temperature by more than 10°C (if you are using a pipe, its length must not exceed 400 mm and it must be as straight as possible).

Tab 2.28

POS.	DESCRIPTION
1	Air in air filter
2	Air in intake manifold flow
3	Air in head intake
4	Air in cylinder intake
5	Gas in cylinder outlet
6	Gas in head outlet
7	Outlet gas to muffer
A	Inlet manifold
B	Exhaust manifold
C	Crankcase
D	Exhaust muffer (optional)

Tab 2.29

POS.	DESCRIPTION
H	Air filter cartridge
M	Filter cover
N	Filter support
Q	Dust exhaust valve
R	Dust exhaust valve

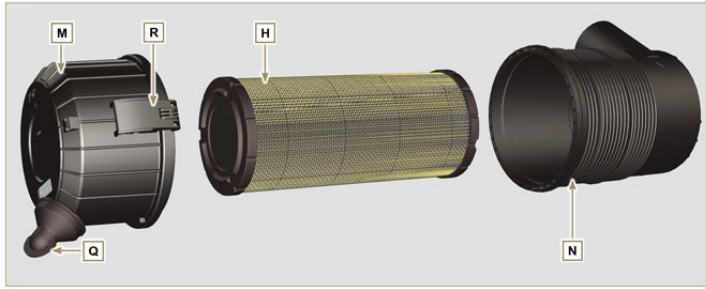


Fig 2.24

2.13 Electric system

2.13.1 Engine electrical wiring (opzional)

NOTE: Component not necessarily supplied by KOHLER.

Electrical wiring is supplied upon request, it interfaces with the panel by means of 19-way Deutsch connectors (female on engine panel - male on accessories panel).

The connectors are described in **Tab. 2.30**.

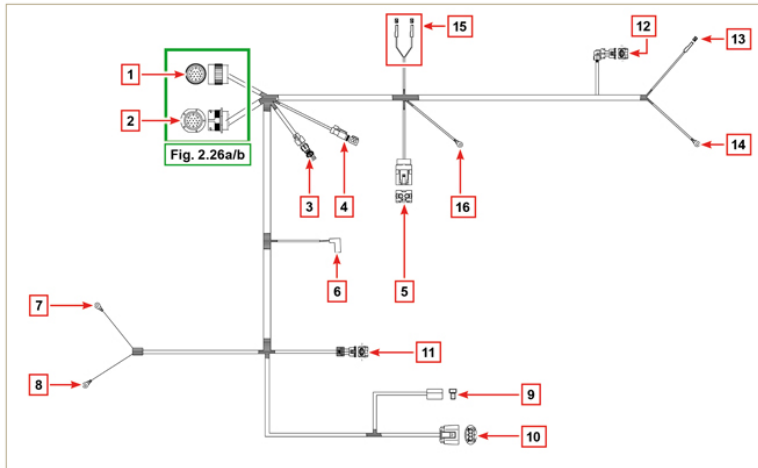


Fig 2.25

Tab 2.30

REF.	DESCRIPTION
1	Engine panel connector interface (Fig. 2.26a)
2	Accessories panel connector interface (Fig. 2.26b)
3	Electrical fuel pump connector
4	Cold Start Advance connector (on injection pump - Fig. 2.39)
5	Fuse connector
6	Electro-Stop connector (on injection pump)
7	"L" alternator connector (Iskra)
8	"W" alternator connectors (Iskra)
9	Alternator connector without "W" (Chengdu)
10	Alternator connector with "W" (Chengdu)
11	Coolant temperature sensor connector
12	Coolant temperature sensor connector
13	Starter motor connector "+ 50"
14	Starter motor connector "+ 30"

15	Air cleaner clogging sensor connector
16	Earth connector

2.13.1.1 Connector panel on the engine/machine

The connector is a female 19-way Deutsch type. There is a list of all PIN connections in **Tab. 2.31**.

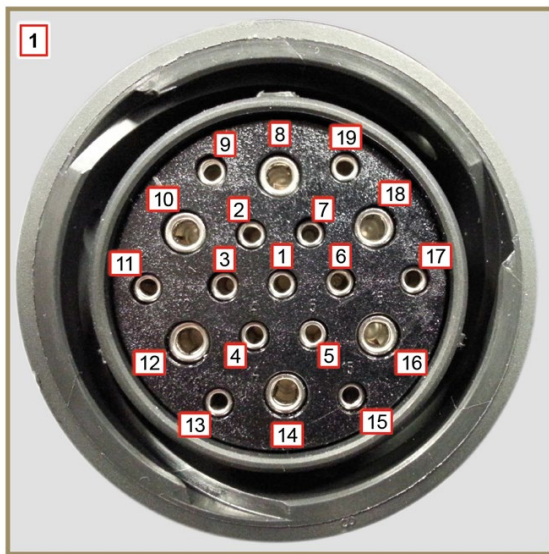


Fig 2.26a

Tab. 2.31

PIN.	INLET SIGNALS TO THE PANEL
1	Oil pressure switch
2	Alternator indicator light
3	Coolant temperature warning light
4	Air cleaner clogging warning light
7	Air cleaner clogging warning light
9	Electro-Stop
13	Alternator (W)
14	Starter motor (+ 30)
15	Inlet indicator general alarm
PIN.	OUTLET SIGNALS FROM THE PANEL
5	Earth
6	IG excitation alternator (+15 wrench)
8	Starter motor (+ 50)
10	Grid heater (Relay)
11	Electric pump
18	Injection pump (Cold Start Advance - Fig. 2.39)

Tab. 2.32

PIN.	INLET SIGNALS TO THE PANEL
2	Fuel filter (water detection sensor)
4	Radiator (coolant level sensor)
7	Outlet indicator general alarm
9	External Stop
15	Inlet indicator general alarm
1	Fuel tank (fuel level sensor)
PIN.	OUTLET SIGNALS FROM THE PANEL
5	Earth
6	Relay with 5A fuse (+ 15 wrench)
10	Grid heater (Relay)
13	Alternator (W)
17	Coolant temperature warning light

2.13.1.2 Accessories panel connector

The connector is a male 19-way Deutsch type.
There is a list of all PIN connections in **Tab. 2.32**.

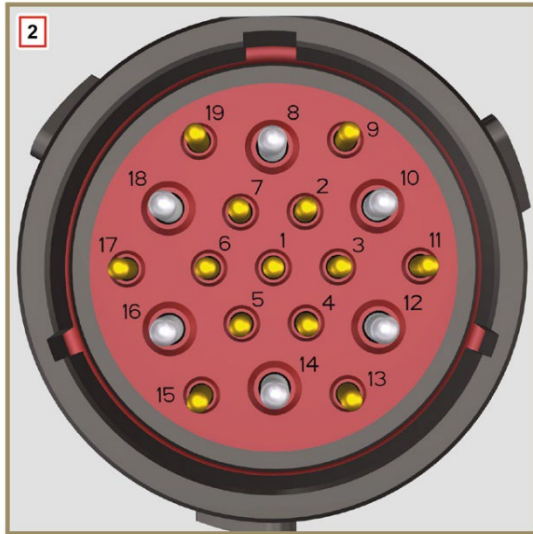


Fig 2.26b

2.13.3.1 Wiring disconnection

Some sensor connectors and electronic control devices are sealed.
This type of connectors must be disconnected by means of pressure on tabs **A** or unblock the retainers **B**, as illustrated from **Fig. 2.26c** to **Fig. 2.26g**.

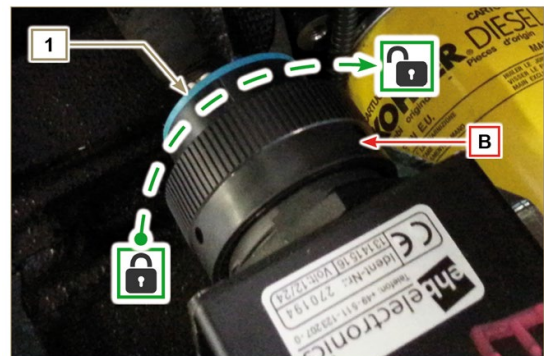


Fig 2.26c

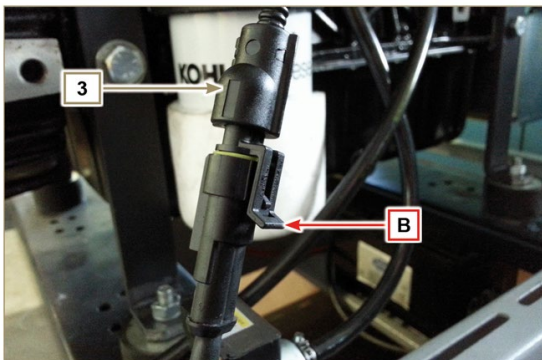


Fig 2.26d

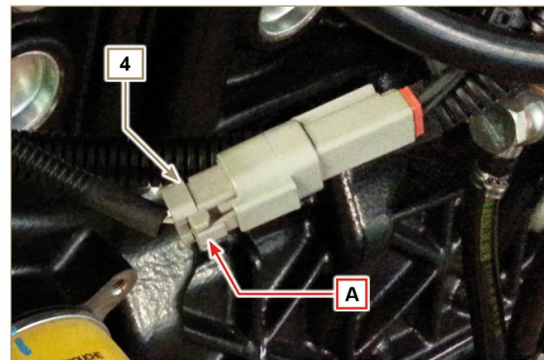


Fig 2.26e



Fig 2.26f

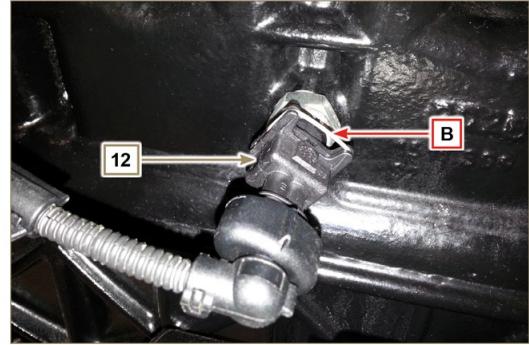


Fig 2.26g

2.14 Sensors and switches

2.14.1 Fuel filter water detection sensor (optional)

The water presence sensor in the fuel filter serves to indicate the presence of water in the fuel. The sensor closes the electrical circuit and the warning lamp in the panel board switches on the dashboard of the car on which the motor is mounted.

Water, if present in the fuel, because of its greater specific weight separates and settles in the lower part of the filter where there is a drain plug. Gently loosen the water drain plug without removing it and spill out the water if present. Retighten the water drain plug **H** as soon as the fuel spills.

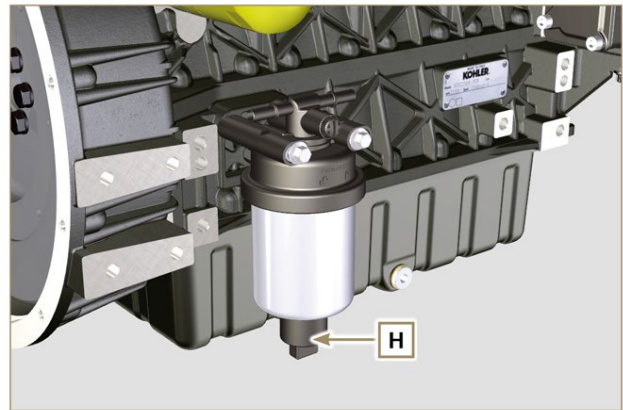


Fig 2.27

2.14.2 Oil pressure switch

Oil pressure switch **N** is assembled on the crankcase.

It is a N/C sensor, calibrated at $0.6 \text{ bar} \pm 0.1 \text{ bar}$. With oil low pressure the sensor closes the electrical circuit and the warning lamp in the panel board switches on.

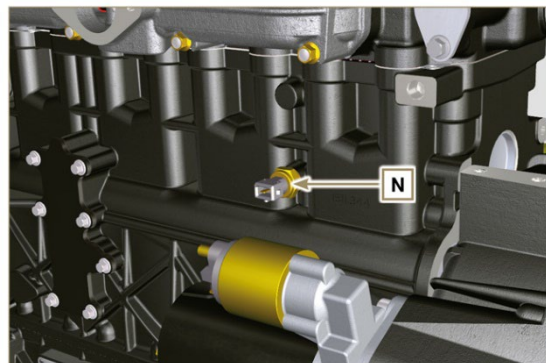


Fig 2.28

2.14.3 Coolant temperature sensor connector

The sensor has the dual function of a thermometer and thermal contact.

The coolant/thermal contact **P** temperature probe is applied to the cylinder head on the side of the thermostatic valve.

Sensor **P1** or **P2** (Fig. 2.29) can be assembled on the engine:

P1 Characteristics indicated in **Tab. 2.33A** (blue connector). Thermal contact N/O with closing temperature at +110 °C ±3°C, re-opening +88 °C / +100 °C.

P2 Characteristics indicated in **Tab. 2.33B** (white connector).

Thermal contact N/O with closing temperature at +110 °C ±3°C, re-opening +88 °C / +100 °C.

NOTE: **R** indicates the pin where it is possible to measure electrical resistance.

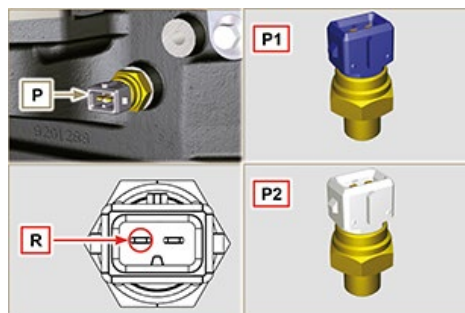


Fig 2.29

Tab 2.33A

SENSOR P1 CHARACTERISTICS		
Temperatura °C	R min Ω	R max Ω
-35	53.983	73.806
-30	39.229	52.941
-15	18.006	20.825
0	7.095	8.929
30	1.717	2.039
60	0.520	0.589
90	0.188	0.204
120	0.076	0.084

Tab 2.33B

SENSOR P2 CHARACTERISTICS		
Temperatura °C	R min Ω	R max Ω
-36	11.835	15.724
-30	8.258	10.834
-16	3.721	4.753
0	1.611	2.003
30	414,1	493
60	132	151,7
90	50,27	56,11
120	21,6	24,29

2.14.4 Air cleaner clogging switch

NOTE: Component not necessarily supplied by **KOHLER**.

The switch is assembled on the air cleaner. When the filter is clogged, it sends a signal to the panel.

Features:

- Operating temperature: -30 °C / +100°C
- Contact usually open.
- Contact closed by vacuum: -50 mbar.

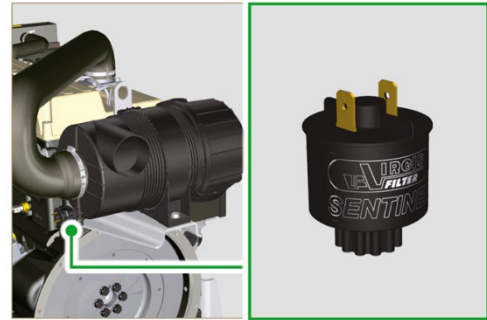


Fig 2.30

2.15 Electrical components

2.15.1 Alternator (A)

Externally controlled by the crankshaft by means of a belt.

- Ampere 55 A
- Volt 12V

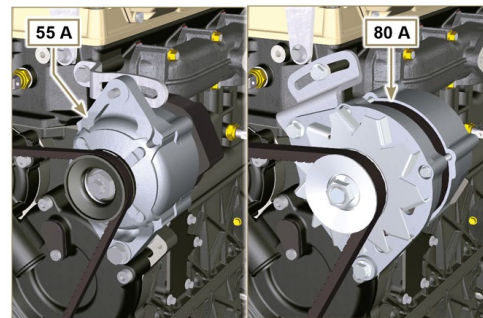


Fig 2.31

2.15.2 Starter Motor (C)

- Type Bosch 12 V
- Potenza 2 kW
- Anticlockwise rotation (seen from timing system side)

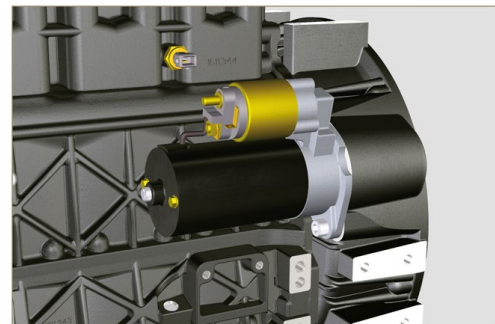


Fig 2.32

2.15.3 Cold starting device (Heater)

The cold starting device consists of a resistance, managed by the ECU, which is activated when the ambient temperature is $\leq -16^{\circ}\text{C}$.

The intake air is heated through the resistor and facilitates starting the engine.

Characteristics:

- Type Hidria AET 12 V
- Power 550 W

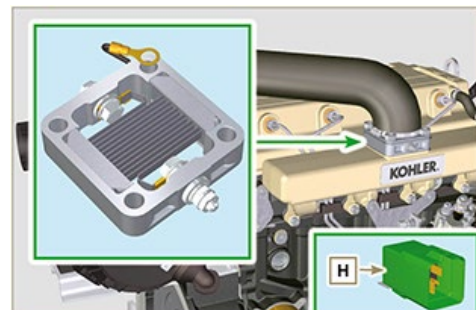


Fig 2.33

2.15.4 Electric pump (optional)

NOTE: Component not necessarily supplied by KOHLER.

The electric pump is located before the fuel filter. One of the following pumps can be assembled **A1 - A2 - A3 - A4**.

Tab. 2.34 a-b-c-d indicates the pumps' features.

POS.	DESCRIPTION
1	Electrical connection
2	Pre-filter pump
IN	Ingoing fitting (IN) from tank
OUT	Outgoing fitting (OUT) to fuel filter

Tab 2.34a

A1	VALUE
Voltage	12 - 24 V
Delivery	100 L/h @ 0.44 - 0.56 bar

Tab 2.34b

A2	VALUE
Voltage	12 V
Delivery	60.56 L/h @ 0.41 bar

Tab 2.34c

A3	VALUE
Voltage	12 V
Delivery	24 L/h @ 0.1 bar

Tab 2.34d

A4	VALUE
Voltage	12 V
Delivery	30 L/h @ 0.4 bar

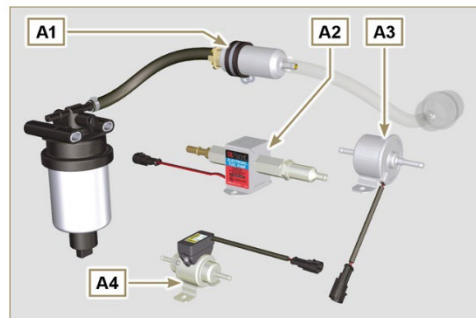


Fig 2.34

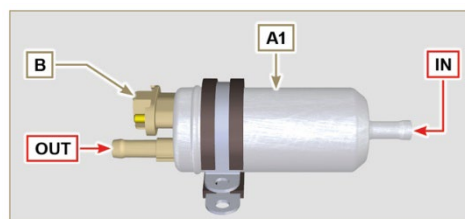


Fig 2.35

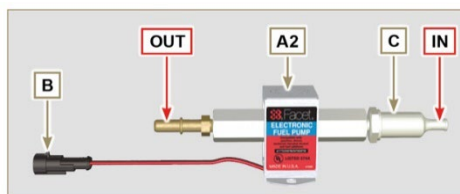


Fig 2.36

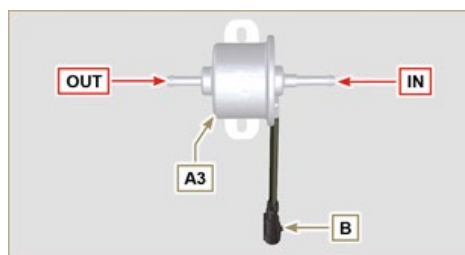


Fig 2.37

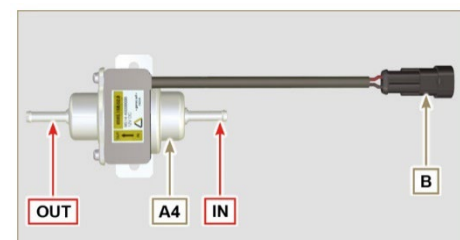


Fig 2.38

2.15.5 Cold start advance

The Cold Start Advance **E** device is part of injection pump **D**; it provides for advance injection modification to enable advance of the engine at low temperatures. The device is controlled by the ECU **H**.

2.15.6 Electro-Stop

The electro-stop **F** device is part of injection pump **D**; it turns off the engine by blocking the flow of fuel into pump **D**.

2.15.7 ECU starting

The **H** device assists cold engine ignition controlling the "cold starting device" (**Heater**) and the "Cold Start Advance" (**CSA**). **Tab. 2.35a** indicates the activation times based on the ambient temperature.

Tab. 2.35a

°C	HEATER	CSA
≤ 20 ÷ -15	0"	120"
- 16	16"	
- 21	21"	
-26	26"	
≤ -32	32"	

Tab. 2.35b

POS.	DESCRIPTION
1	Heater
2	50 - ignition
3	15 - ignition
4	CSA
5	30 - battery
6	...
7	Earth
8	Control panel indicator

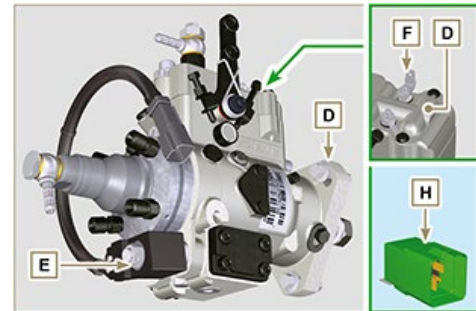


Fig 2.39

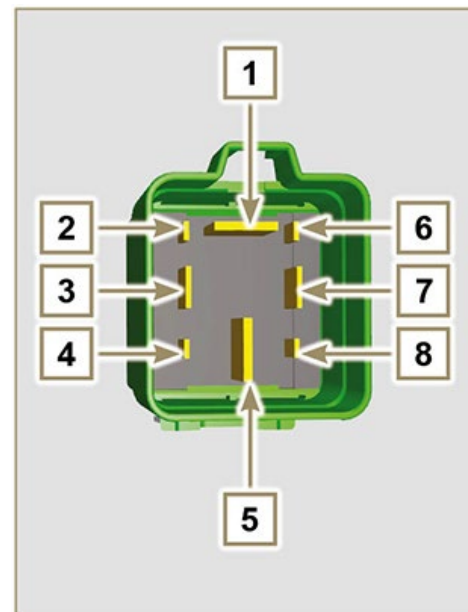


Fig 2.40

2.15.8 Fuse

Device **G** is assembled on cylinder head **P** (flywheel side); it protects the electrical circuit in the event of an overload or short circuit.

NOTE: Component not necessarily supplied by **KOHLER**.

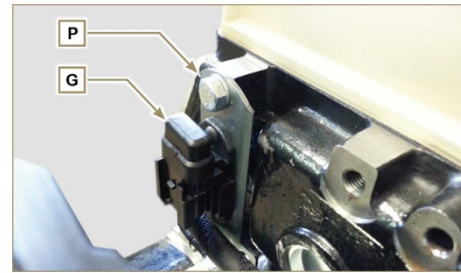


Fig 2.41

2.15.9 Control panel (optional)

Panel **L** can be assembled on the engine or machine. The connectors are described in **Tab. 2.36**, the main functions are illustrated.

NOTE: Component not necessarily supplied by **KOHLER**.

Tab 2.36

POS.	DESCRIPTION
M	Hour-meter indicator
S	Control switch to start the engine
W1	Panel ignition indicator
W2	Warning Light - battery not charging
W3	Warning Light - engine oil not pressurised
W4	Warning Light - high coolant temperature
W5	Warning Light - alarm general indicator

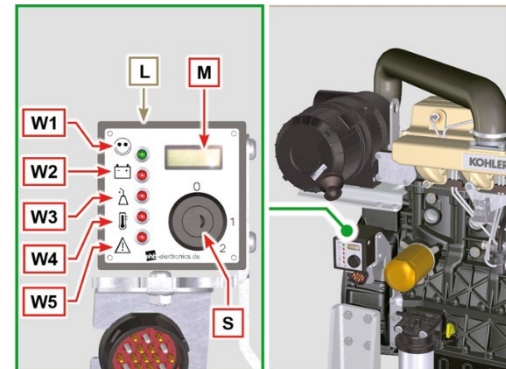


Fig 2.42

2.16 Timing system and tappets

The timing system is equipped with hydraulic tappets that automatically recover the operation of the rocker rods assembly.

No registration is therefore required.

2.16.1 Components identification

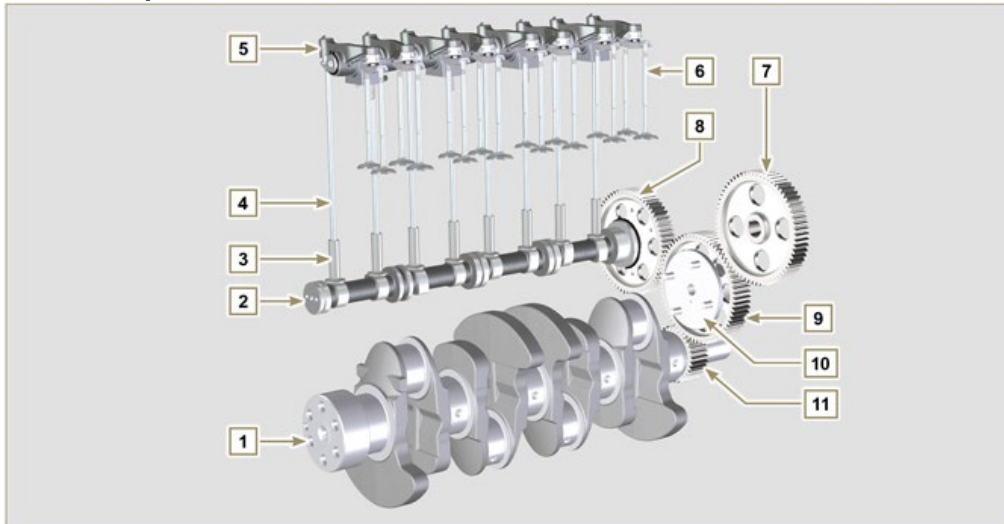


Fig 2.43

Tab 2.37

POS.	DESCRIPTION
1	Crankshaft
2	Camshaft
3	Camshaft tappets
4	Rocker arm control rod
5	Rocker arms
6	Valves
7	Injection pump control gear
8	Camshaft control gear
9	Intermediate gear
10	Intermediate gear pin
11	Crankshaft gear
12	Valve control bridge
13	Articulation control valves
14	Hydraulic tappets

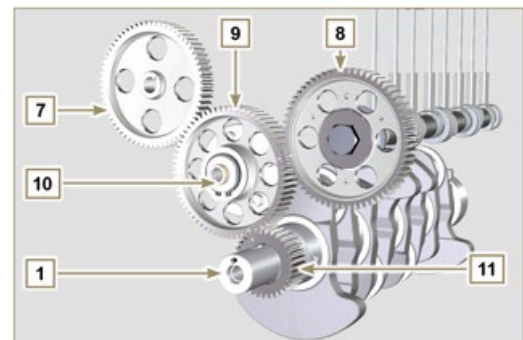


Fig 2.44

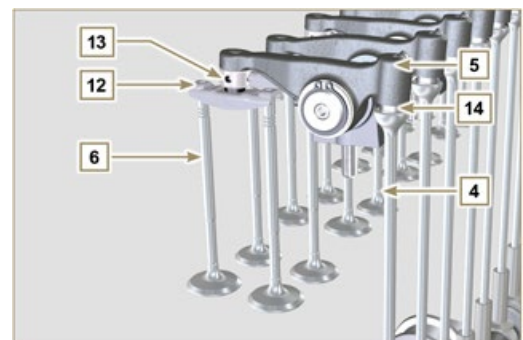


Fig 2.45

2.16.2 Rocker arm pin

Tab 2.39

POS.	DESCRIPTION
1	Rocker arm pin
2	Rocker arm distancing spring
3	Rocker arm pin support
4	Exhaust rocker arm
5	Intake rocker arm

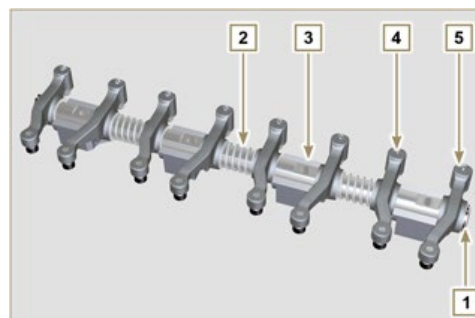


Fig 2.47

2.16.3 Rocker arms

Tab 2.40

POS.	DESCRIPTION
1	Rocker arm body
2	Hydraulic tappet oil refill line
3	Valve tappet lubrication line
4	Valve tappet
5	Hydraulic tappet
6	Oil flow line

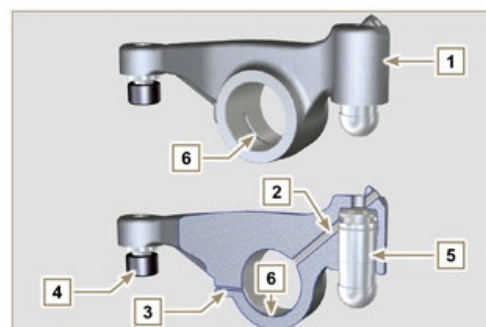


Fig 2.48

2.16.4 Hydraulic tappets

Tab 2.41

POS.	DESCRIPTION
A	Hydraulic tappets
B	High pressure chamber
1	Hydraulic tappets oil refill pipe
2	Retaining ring
3	Piston
4	Unidirectional valve
5	Tappet body

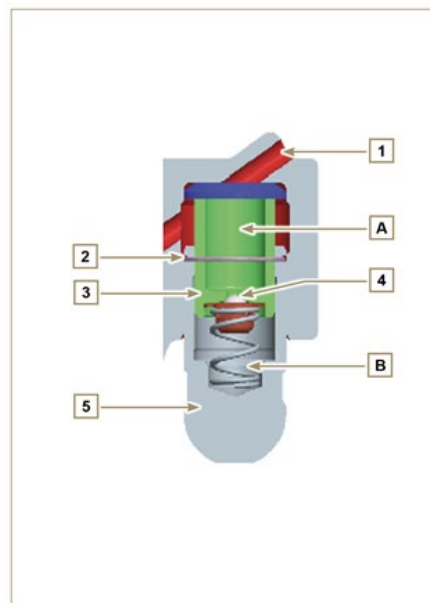


Fig 2.49

2.16.4.1 Hydraulic tappet operation

The operating principle of the hydraulic tappet is based on the incompressibility of the liquids and on controlled leakage.

The oil under pressure enters the tappet chamber **A**, providing a constant supply of oil in the low-pressure chamber.

Through the non-return valve, **4** the oil can only access the high-pressure chamber **B** and exit via the clearance between the piston **3** and the tappet body **5** (controlled leakage).

The chamber **B** is filled when the rocker arm is on the base radius of the cam and the spring **6** keeps the piston

3 against the valve stem, thus eliminating any system play. Thanks to the spring extension, the tappet extends", creating a small depression in the chamber **B**, making the non-return valve **4** open, and allowing the oil in the chamber **A** to pass to chamber **B**, restoring the proper amount of oil required to eliminate any play in the valves.

2.16.5.2 Difficult operating conditions

For proper operation on the hydraulic tappets it is essential that the low pressure chamber of the piston **3** is always full of oil.

In some conditions this may not occur (due to the fact that the oil leaks away when the engine is switched off, which can also partially drain the tappets). This situation will be the cause of clearances that will result in a characteristic noise similar to a ticking sound.

1. When the engine is cold, the tappet filling time could be very long if the oil used is not suitable for the specific environmental conditions (**Tab. 2.2**)
2. If the engine is very hot: at idle speed, oil pressure may be low, and small air bubbles could form in the circuit. Because of this, this compressing the tappet slightly and producing valve play which is responsible for the ticking sound. On account of this, the tappet compresses slightly giving rise to a valve clearance, thus generating a slight ticking sound, which however disappears rapidly (**MAX 10 seconds**) once normal operating conditions have been restored.

Anyway the duration of ticking sound must be **MAX 30 seconds**. If not, the problem is surely due to the poor quality of the oil, wear or impurities that, transported by the oil, can infiltrate between the ball valve and its seat inside the piston, compromising the operation of the tappet itself; In these cases, the only solution is to replace the oil or hydraulic tappets.

The prolonged persistence of the ticking sound or abnormal noise must be investigated in order to prevent any malfunctions; if necessary, replace the hydraulic tappets and engine oil.

2.17 Components handling

2.17.1 Injection pump

- Only handle by means of the points marked by **Y**.
- It is forbidden to handle using the points marked by **N**.

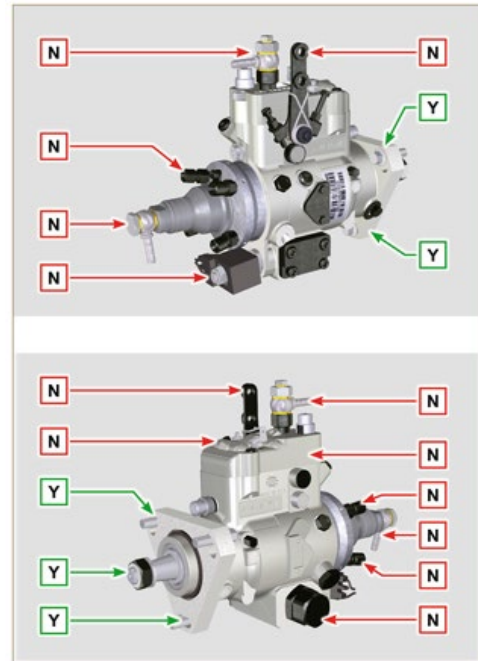


Fig 2.50

2.17.2 Injector

- Only handle by means of the points marked by **Y**.
- It is forbidden to handle using the points marked by **N**.

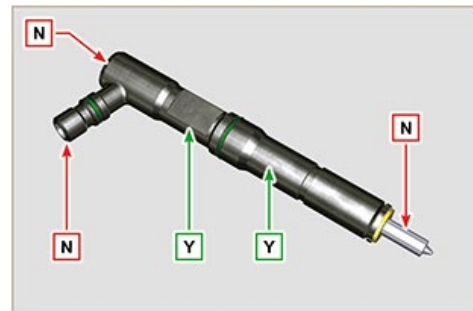


Fig 2.51

2.18 Balancer device (optional)

The balancer device is composed of a special crankshaft that activates 2 additional shafts (balancers). Rotation of the balancers, which have counterweights that oppose the movement of alternating weights (crankshaft - connecting rods - pistons), reduces vibrations caused by them.

The device is developed under the crankshaft, fixed on the crankcase, closed by the oil sump.

Tab 2.43

POS.	DESCRIPTION
1	Crankshaft
2	Balancer shaft control gear
3	Balancer shaft support box
4	Conductor balance shaft
5	Conducted balance shaft

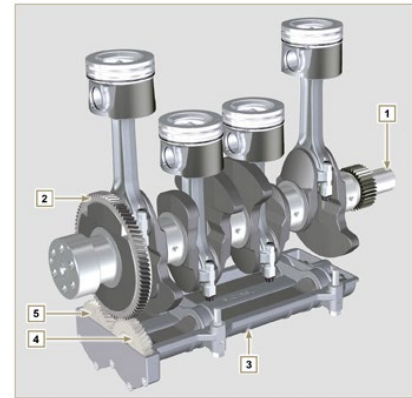


Fig 2.67

3 SAFETY INFORMATION

3.1 Before start-up

- Read the manual carefully and carry out the operations described below in compliance with the instructions specified.
- Periodic inspection and maintenance operations must be carried out as indicated in this manual and under the user's responsibility.



Important

- Only use original spare parts and accessories.
- The use of non-original parts, as well as voiding the warranty, affects the life and performance of the engine, and may be dangerous.
- Non compliance with the operations described in the following pages may result damage to the engine and vehicle on which it is installed, as well as to people and/or property.

3.2 Safety precautions

- The intended use of the engine is in conformity with the machine on which it is mounted.
- Any use of the machine other than that described cannot be considered as complying with its intended purpose as specified by **KOHLER**.
- **KOHLER** declines all responsibility for any change to the engine not described in this manual made by unauthorized **KOHLER** personnel.
- A proper use of the engine, a strict observance of the rules listed below and the rigorous application of all these precautions will avoid the risk of accidents or injuries.
- Those who carry out the use and maintenance on the engine must wear the safety equipment and the accident-prevention guards [Par. 3.4.3](#)
- **KOHLER** declines all direct and indirect liability for failure to comply with the standards of conduct contained in this manual.
- **KOHLER** cannot consider every reasonably unforeseeable misuse that may cause a potential danger.

3.3 General remarks

3.3.1 Note for OEM

- When installing the **KDI** engines, always bear in mind that any variation to the functional systems may involve serious failures to the engine.
- Any improvement must be verified at **KOHLER** testing laboratories before application of the engine.
- In the event **KOHLER** does not approve the type of modification, **KOHLER** shall not be held responsible for any consequential operation anomalies that the engine may undergo and any damage the engine may cause to persons and things.
- The engine may only be assembled on a machine by personnel specifically trained by **KOHLER** and who work in compliance with the existing documentation.
- The engine has been built to the specifications of a machine manufacturer, and it is his responsibility to ensure that all necessary action is taken to meet the essential and legally prescribed health and safety requirements. Any use of the machine other than that described cannot be considered as complying with its intended purpose as specified by **KOHLER**, which therefore declines all responsibility for accidents caused by such operations.

3.3.2 Note for end user

- The following indications are dedicated to the user of the machine in order to reduce or eliminate risks concerning engine operation and the relative routine maintenance work.
- The user must read these instructions carefully. Failure to do this could lead to serious danger for his personal safety and health and that of any persons who may be in the vicinity of the machine.
- On starting, make sure that the engine is as horizontal as possible, unless the machine specifications differ.
- Make sure that the machine is stable to prevent the risk of overturning.
- The engine must not operate in places containing inflammable materials, in explosive atmospheres, where there is dust that can easily catch fire unless specific, adequate and clearly indicated precautions have been taken and have been certified for the machine.
- To prevent fire hazards, always keep the machine at least one meter from buildings or from other machinery.
- Children and animals must be kept at a due distance from operating machines in order to prevent hazards deriving from their operation.
- Thoroughly wash and clean all the external parts of the engine before performing any operation, in order to avoid the accidental introduction of impurities/foreign bodies. Use only water and/or appropriate products to clean the engine. If cleaning engine with a pressure washer or steam cleaner, it is important to maintain a minimum distance of at least 200mm between the surface to be washed and the nozzle. Avoid directing the nozzle on electrical components, cable connections and sealed rings (oil seals etc). Thoroughly wash and clean the area surrounding the engine following the instructions provided by machine manufacturer.
- Fuel vapour is highly toxic. Only refuel outdoors or in a well ventilated place.
- Make sure that no soundproofing panels and the ground or floor on which the machine is standing have not soaked up any fuel.
- The engine may only be assembled on a machine by personnel specifically trained by **KOHLER** and who work in compliance with the existing documentation.
- The engine has been built to the specifications of a machine manufacturer, and it is his responsibility to ensure that all necessary action is taken to meet the essential and legally prescribed health and safety requirements. Any use of the machine other than that described cannot be considered as complying with its intended purpose as specified by **KOHLER**, which therefore declines all responsibility for accidents caused by such operations.
- Fuel vapour is highly toxic. Only refuel outdoors or in a well ventilated place.
- Do not smoke or use open flames when refuelling.
- During operation, the surface of the engine can become dangerously hot. Avoid touching the exhaust system in particular.
- Before proceeding with any operation on the engine, stop it and allow it to cool.
- Always open the radiator plug or expansion chamber with the utmost caution, wearing protective garments and goggles.
- The coolant fluid is under pressure. Never carry out any inspections until the engine has cooled.
- If there is an electric fan, do not approach the engine when it is still hot as the fan could also start operating when the engine is at a standstill.
- The oil must be drained whilst the engine is hot. Particular care is required to prevent burns. Do not allow oil to come into contact with the skin because of the health hazards involved. It is recommended to use an oil intake pump.
- During operations that involve access to moving parts of the engine and/or removal of rotating guards, disconnect and insulate the negative wire (-) of the battery to prevent accidental short-circuits and to stop the starter motor from being energized.
- Check belt tension only when the engine is off.
- Fully tighten the tank cap each time after refuelling. Do not fill the tank right to the top but leave an adequate space for the fuel to expand.
- To start the engine follow the specific instructions provided in the engine and/or machine operating manual. Do not use auxiliary starting devices not originally installed on the machine (e.g. Startpilot).

- Before starting, remove any tools that were used to service the engine and/or machine. Make sure that all guards have been refitted.
- Do not mix fuel with elements such as oil or kerosene. Failure to comply with this prohibition will cause the non-operation of the catalyst and non-observance of the emissions declared by **KOHLER**.
- Pay attention to the temperature of the oil filter when the filter itself is replaced.
- Only check, top up and change the coolant fluid when the engine is off and reached the ambient temperature. Coolant fluid is polluting, it must therefore be disposed of in the correct way.
- Do not use jets of air and water at high pressure on the cables, connectors and injectors.



Important

- Only use the eyebolts **A** installed by **KOHLER** to move the engine (**Fig. 3.1**).
- The angle between each lifting chain and the eyebolts shall not exceed 15° inwards.
- The correct tightening of the lifting brace capscrews is **25 Nm**.
- Do not interpose spacers or washers between the eyebolts and engine head.

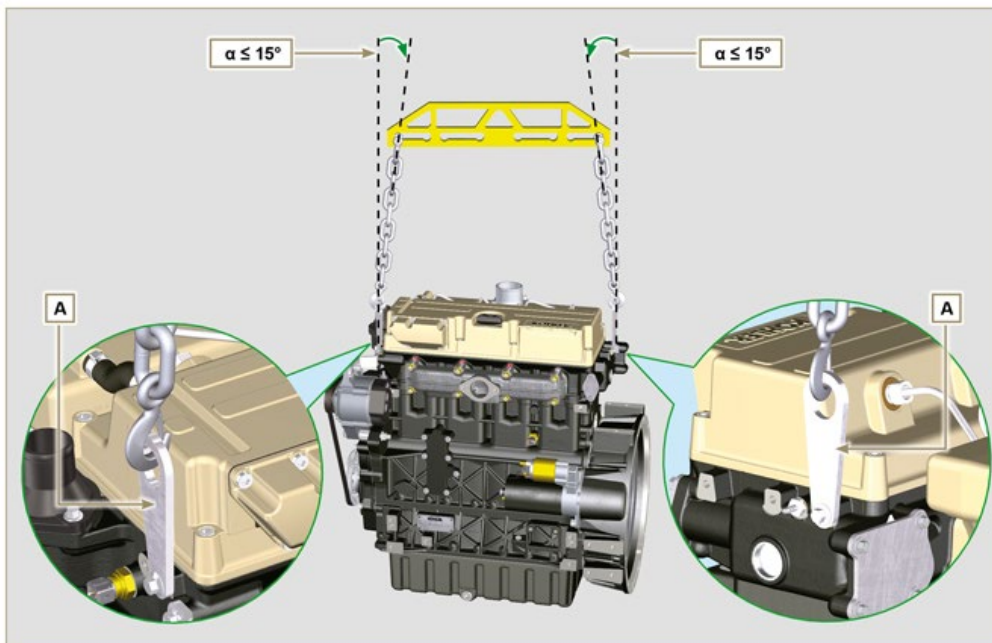









Fig 3.1





3.4 Safety signal description

- To ensure safe operation please read the following statements and understand their meaning.
- Also refer to your equipment manufacturer's manual for other important safety information.
- This manual contains safety precautions which are explained below.
- Please read them carefully.


Adhesive safety plates

The following is a list of the adhesive safety plates that may be found on the engine, which indicate potential points of danger to the operator.


	<p>Read the Operation and Maintenance handbook before performing any operation on the engine.</p>
	<p>Hot Parts. Danger of burns.</p>
	<p>Presence of rotating parts. Danger of jamming or cutting.</p>
	<p>Presence of explosive fuel. Danger of fire or explosion.</p>
	<p>Presence of steam and pressurized coolant. Danger of burns.</p>
<p>Warnings Hereunder is a list of safety warnings that may be found in the manual, which advise you to pay attention when carrying out particular procedures that may be potentially dangerous to the operator or things.</p>	
	<p>Danger This indicates situations of grave danger which, if ignored, may seriously threaten the health and safety of individuals.</p>
	<p>Important This indicates particularly important technical information that should not be ignored.</p>

	<p>Warning This indicates that failure to comply with it can cause minor damage or injury.</p>
<p>Safety guards Hereunder is a list of safety guards that must be worn prior to carrying out any type of operation and to avoid potential harm to the operator.</p>	
	Use suitable protective gloves before carrying out any type of operation.
	Use protective goggles before carrying out any type of operation.
	Use earmuffs before carrying out any type of operation.

3.5 Information and safety signals





ACCIDENTAL START

	<p>Accidental Starts can cause severe injury or death.</p>
<p>Before working on the engine or equipment, disconnect the battery negative (-) wire.</p>	





HOT PARTS

	<p>Hot Parts can cause severe burns.</p>
<p>Engine components can get extremely hot from operation. Do not touch engine while operating or just after stopping.</p> <p>Never operate the engine with heat shields or guards removed.</p>	




HIGH PRESSURE FLUID RISK OF PUNCTURE

	<p>High Pressure Fluids can puncture skin and cause severe injury or death.</p>
<p>Work on the injection system must be carried out by suitably trained staff wearing protection equipment. Injuries caused by fluid penetration are highly toxic and dangerous.</p> <p>If an injury occurs, seek immediate medical attention.</p>	



EXPLOSIVE FUEL

	<p>Explosive fuel can cause fires and severe burns.</p>
<p>Fuel is flammable and its vapours can ignite. Store fuel only in approved containers, in well ventilated, unoccupied buildings. Do not fill the fuel tank while the engine is hot or running, since spilled fuel could ignite if it comes in contact with hot parts or sparks from ignition. Do not start the engine near spilled fuel. Never use fuel as a cleaning agent.</p>	



ROTATING PARTS



Rotating Parts can cause severe injury.

Stay away while engine is in operation. Keep hands, feet, hair, and clothing away from all moving parts to prevent injury. Never operate the engine with covers, shrouds, or guards removed.



LETHAL EXHAUST GASES



Carbon Monoxide can cause severe nausea, fainting or death.

Avoid inhaling exhaust fumes and never run the engine in a closed building or confined area. Carbon monoxide is toxic, odorless, colorless, and can cause death if inhaled.



ELECTRICAL SHOCK



Electrical Shock can cause injury.

Do not touch wires while engine is running.



EXPLOSIVE GAS



Explosive Gas can cause fires and severe acid burns.

Charge battery only in a well ventilated area. Keep sparks, open flames, and other sources of ignition away from the battery at all times. Batteries produce explosive hydrogen gas while being charged.

Keep batteries out of the reach of children. Remove all jewelry when servicing batteries. Before disconnecting the negative (-) ground cable, make sure all switches are OFF. If ON, a spark will occur at the ground cable terminal which could cause an explosion.



CALIFORNIA WARNING - DECLARATION 65

Engine exhaust from this product contains chemicals known to the State of California to cause cancer, birth defects, or other reproductive harm.

3.6 Safety and environmental impact

Every organisation has a duty to implement procedures to identify, assess and monitor the influence of its own activities (products, services, etc.) on the environment. Procedures for identifying the extent of the impact on the environment must consider the following factors:

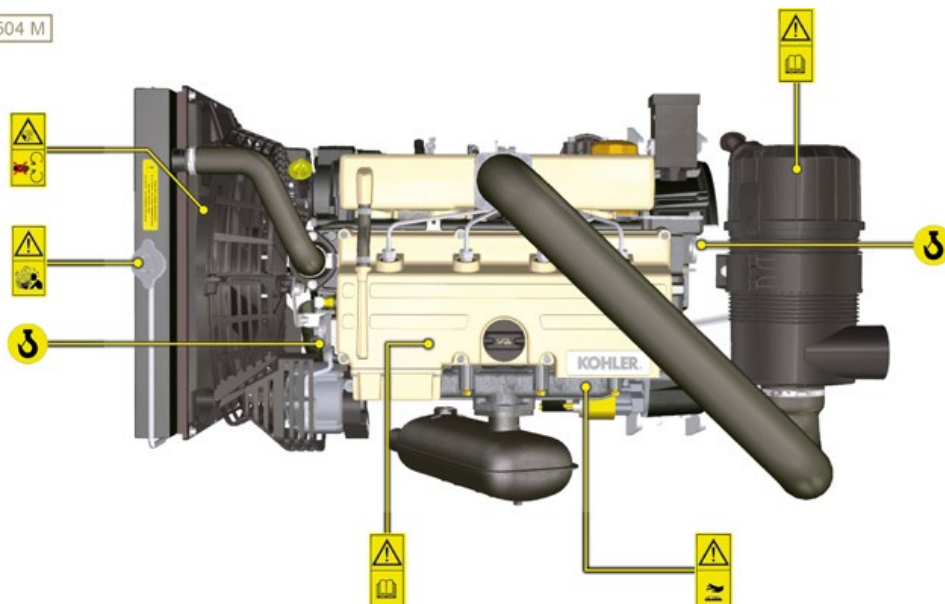
- Disposal of liquids.
- Waste management.
- Soil contamination.
- Atmospheric emissions.
- Use of raw materials and natural resources.
- Regulations and directives regarding environmental impact.

In order to minimise the impact on the environment, **KOHLER** provides some indications to be followed by all those handling the engine, for any reason, during its expected lifetime.

- All components and fluids must be disposed of in accordance with the laws of the country in which disposal is taking place.
- Keep the injection system as well as engine management and exhaust pipes in efficient working order to limit environmental and noise pollution.
- When decommissioning the engine, select all components according to their chemical characteristics and dispose of them separately.

3.7 Location of safety signals on engine

KDI 2504 M



4 STORAGE INFORMATION

4.1 Product preservation



Important

- If the engines are not to be used for 6 months, they must be protected by carrying out the operations described in Engine storage (up to 6 months) (**Par. 4.2**).
- If the engine is still not in use after the first 6 months, it is necessary to carry out a further procedure to extend the protection period (more than 6 months) (**Par. 4.3**).
- If the engine is not to be used for an extended period, the protective treatment procedure must be repeated within 24 months of the previous one.

4.2 Engine storage (up to 6 months)

Before storing the engine check that:

- The environments are not humid or exposed to bad weather. Cover the engine with a proper protective sheet against dampness and atmospheric contaminants.
- The place is not near electric panel.
- Avoid storing the engine in direct contact with the ground.

4.3 Engine storage (over 6 months)

Follow the steps described in **Par. 4.2**.

1. Pour protective oil in the carter up to the **MAX** level.
2. Refuel with fuel additives for long storage.
3. With expansion tank:
make sure that the coolant is up to the **maximum** level.
4. Without expansion tank: Top liquid up until the pipes inside the radiator are covered by about 5 mm.
Do not overfill the radiator, but leave room for the fuel to expand.
5. Start the engine and run it at idle speed for around 2 minutes.
6. Bring the engine to 75% of **maximum** rated speed for 5 to 10 minutes.
7. Turn off the engine.
8. Empty out completely the fuel tank.
9. Spray SAE x10W-40 on the exhaust and intake manifolds.
10. Seal the exhaust and intake ducts to prevent foreign bodies from entering.
11. Thoroughly clean all external parts of the engine. When cleaning the engine, if using a pressure washer or steam cleaning device, avoid directing the nozzle on electrical components, cable connections and sealed rings (oil seals etc).
If cleaning engine with a pressure washer or steam cleaner, it is important to maintain a minimum distance of at least 200mm between the surface to be washed and the nozzle - avoiding absolutely electrical components such as alternators, starter motors and engine control units (ECU).
12. Treat non-painted parts with protective products.
13. Loosen the alternator belt **Par. 7.2.3 point 1 and 2**

If the engine protection is performed according to the suggestions indicated no corrosion damage will be found.

4.4 Engine starting after storage

1. Remove the protective sheet.
2. Use a cloth soaked in degreasing product to remove the protective treatment from the external parts.
3. Inject lubricating oil (no more than 2 cm³) into the intake ducts.
4. Adjust the alternator belt tension (**Par. 9.14.2 from points 7 to 10**) or replace if there are signs of deterioration.
5. Refill the tank with fresh fuel.



Warning

- Over time, lubricants and filters lose their properties, so it is important to consider whether they need replacing, also based on the criteria described in **Tab. 2.7 - 2.8**.
6. Make sure that the oil and the coolant are up to the **maximum** level.
 7. Start the engine and run it at idle speed for around 2 minutes.
 8. Bring the engine to 75% of **maximum** rated speed for 5 to 10 minutes.
 9. Stop the engine and while the oil still hot, perform the operation in **Par. 5.2**.
 10. Replace the filters (air, oil, fuel) with original spare parts.
 11. Perform the operations described in **Par. 10.1**.
 12. Perform the operations described in **Par. 5.1** and **Par. 10.2**.

5 INFORMATION REGARDING DISCHARGE OF LIQUIDS

5.1 Coolant



Important

- Before proceeding with operation, read [Par. 3.3.2](#).

NOTE: Component not necessarily supplied by **KOHLER**.

The representation of the radiator is purely indicative.



Warning

- Presence of steam pressurized coolant danger of burns.

1. Undo the cap **A** carefully (circuit under pressure).
2. Loosen cap **D**, remove gasket **E**, drain all coolant in radiator **G** into a suitable container and refer to [Par. 3.6](#).
3. Undo cap **F** to drain all liquid from the system contained in the engine crankcase ducts into an appropriate container ([Par. 3.6](#)).

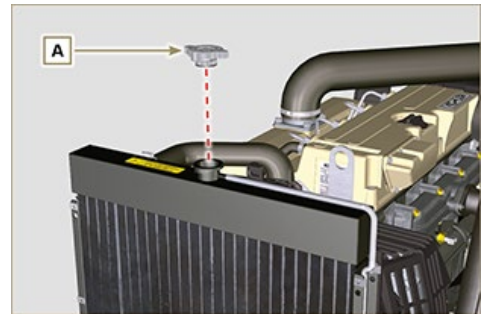


Fig 5.1

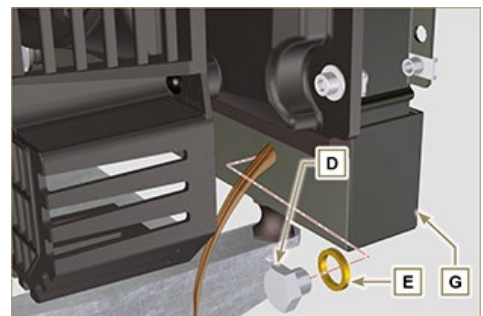


Fig 5.2

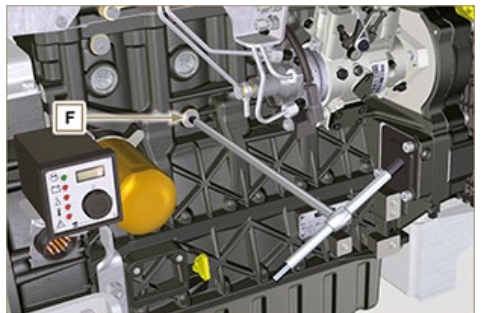


Fig 5.3

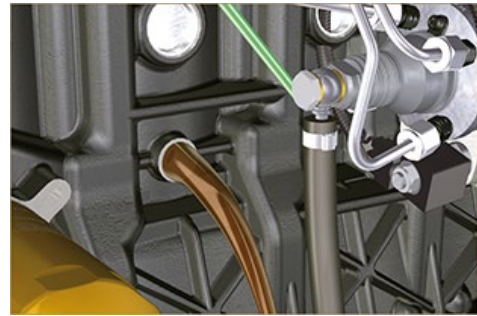


Fig 5.4

NOTE: Click by side to play the procedure.

<https://www.youtube.com/embed/wX Sb6sOYsD8?rel=0>

5.2 Engine oil



Important

- This operation should be carried out with vacuum pump. The oil must be drained whilst the engine is hot, which requires particular care to prevent burns. Do not allow oil to come into contact with the skin because of the health hazards involved. It is recommended to use an oil intake pump via the oil dipstick hole **B**.
- Before proceeding with operation, read **Par. 3.3.2.**

NOTE: Perform this operation with warm engine, to get a better fluidity of the oil and get a full discharge of oil and impurities contained in it.

1. Undo the oil filler cap **A**.
2. Remove the oil dipstick **B**.
3. Remove the oil drain plug **D** and the gasket **E** (the oil drain plug is on both sides of the oil sump).
4. Drain oil in an appropriate container.
(For used oil disposal refer to the **Par 3.6**).
5. Perform the operations described in **Par. 6.6**.

NOTE: Click by side to play the procedure.

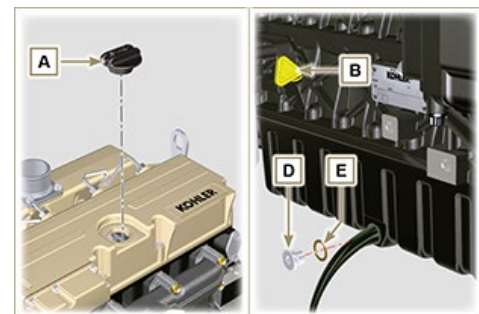


Fig. 5.4

<https://www.youtube.com/embed/Kg Z2JBPCGPk?rel=0>

6 INFORMATION FOR REPLACING THE FUNCTIONAL UNITS

6.1 Injectors and injection pump replacement



Important

- Before proceeding with operation, read [Par. 3.3.2.](#)
- Replace the high pressure pipes after two disassemblies.
- Always replace the gaskets after each disassembly.
- Handle the components as described in [Par. 2.17.](#)
- Please referring to [Par. 2.9.7](#) in order to see the operating references during disassemble and assemble procedures.
- When repaired, **RSN-A** injectors must be certified by a Stanadyne centre to check their correct operation - check the type of engine mounted injectors on the spare parts list (**RSN-A** is specified in the description).



Fig 6.1

6.1.1 injection fuel pump disassembly (injection pump/injectors)

1. Undo the screws **A** and remove plate **B**.
2. Remove the retainers **C** for the hoses **D**.

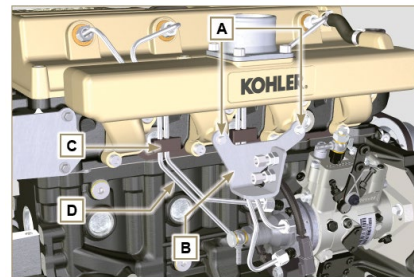


Fig 6.2

3. Undo the nuts **F**.
4. Undo the nuts **E**.
5. Remove the tube **D**.

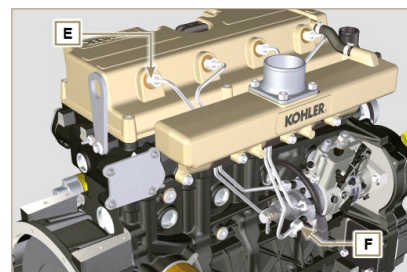


Fig 6.3

6.1.2 Rocker arms cover disassembly

1. Loosen clamp **G** and disconnect hose **H**
2. Undo the screws **L** and remove the rocker arm cap **C**.

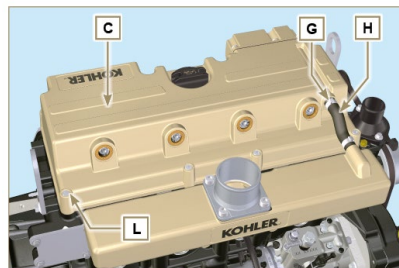


Fig 6.4

6.1.3 Fuel return pipes disassembly

1. Undo the screws **M** and remove hose **N**.

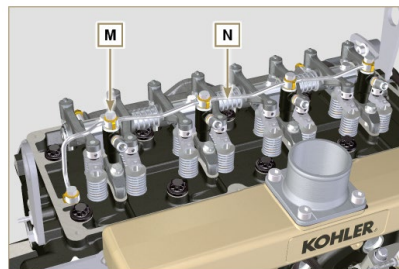


Fig 6.5

6.1.4 Injectors disassembly

1. Undo the screw **P** and remove washer **Q** and bracket **R**.
2. Remove the injector **Z**.

NOTE: Should you be unable to remove the injector (acting only on point **BC**), use an open-ended spanner (11 mm), by applying small rotations to unblock the component.

3. Seal all injection component unions as illustrated in [Par. 2.9.7](#).

NOTE: If the washer **S** is not found on the injector **Z**, recover it from inside the sleeve **V**.

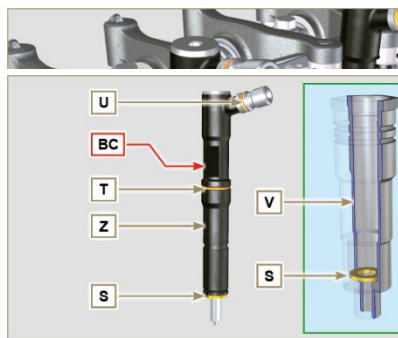


Fig 6.6

Fig 6.7

6.1.5 Injection pump disassembly



Important

- Before proceeding with the disassembly, identify the pump code from its identifying name plate (Pos. 12 - [Tab. 2.12](#)).
- Alternatively, you can identify the pump from the online spare parts catalogue (<https://partners.lombardini.it/App/SparepartCatalogue/Default/Catalogue.aspx>).

1. Insert the tool **ST_30** into the injector N°1 and fix it with the fixing brace **R** of the injector, capscrew **P** and washer **Q**.

NOTE: Do not tighten the capscrew **P**.

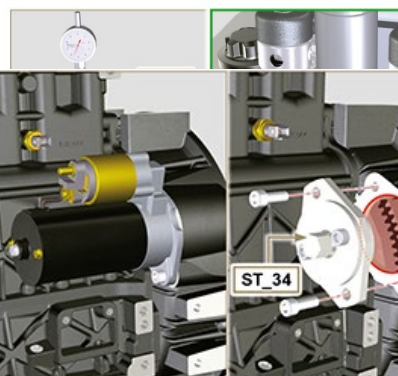


Fig 6.8

Fig 6.9

2. Disassemble the starter motor.
3. Mount the tool **ST_34** in the seat of the starter motor **Y** and fit it with the two starter motor fixing screws.
4. Rotate the crankshaft clockwise **ST_34** tool bringing reference **X** upwards.

NOTE: During the positioning phase of reference **X**, check that cylinder N° 1 is in compression phase (intake and exhaust valves of cylinder N° 1 must be in closing position).

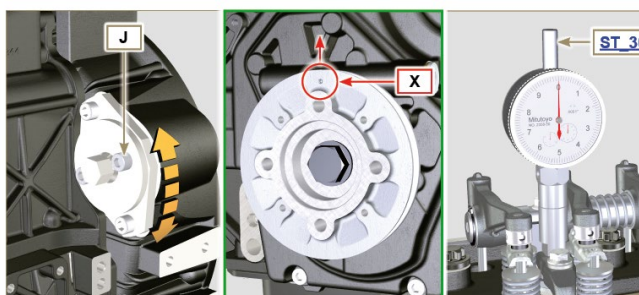


Fig 6.10

Tab. 6.1

PUMP CODE	PISTON LOWERING (mm)	ADVANCE α
ED0065900040-S	1,695	13°
ED0065900060-S	3,591	19°
ED0065900310-S	0,815	9°
ED0065905050-S	1,695	13°
ED0065905110-S	1,963	14°
ED0065905150-S	1,695	13°
ED0065905160-S	1,695	13°
ED0065905170-S	1,695	13°
ED0065905180-S	1,695	13°
ED0065905350-S	1,963	14°
ED0065905380-S	3,228	18°
ED0065905410-S	2,558	16°
ED0065905470-S	1,695	13°
ED0065905500-S	1,695	13°
ED0065905510-S	1,695	13°
ED0065905540-S	1,006	10°
ED0065905640-S	1,695	13°
ED0065905650-S	1,695	13°
ED0065905660-S	1,695	13°
ED0065905670-S	1,695	13°

ED0065905680-S	1,695	13°
ED0065905760-S	1,695	13°
ED0065905790-S	2,558	16°
ED0065905970-S	0,815	9°
ED0065905980-S	1,216	11°

- With reference **X** pointed upwards, find the TDC through tool **ST_30**, then bring the dial gauge indicator to 0.
- Having identified the value to lower the piston, rotate the crankshaft anti-clockwise by going beyond the value described in **Tab. 6.1**, once again, rotate the crankshaft clockwise, stopping at the correct advance value by using tool **ST_30**
- Lock the **ST_34** tool through **J** screws and ensure that the crankshaft does not rotate, which would alter the correct advance value. If this happens, repeat the instructions described in points **4, 5, 6, 7 and 8**.

NOTE: The value indicated in **Tab. 6.1** must be reached by rotating the shaft with the piston in compression phase. Use the **ST_34** tool to totate the crankshaft.

- Lock the **ST_34** tool through **J** screws and ensure that the crankshaft does not rotate, which would alter the correct advance value. If this happens, repeat the instructions described in points **4, 5, 6, 7 and 8**.
- Undo the screws **AC** and remove the oil filling flange **AD**.
- Undo and remove the nut **AN** fixing the injection pump control gear **AE**.
- Undo the capscrew **K** and shift the slotted plate **AB** in the direction of arrow **AA**.
- Tighten screw **K** to block the pump (tightening torque to **12 Nm**).



Important

- After removing the nut **AN**, ensure that the correct advance value has remained unchanged on **ST_30**.

Fig 6.11

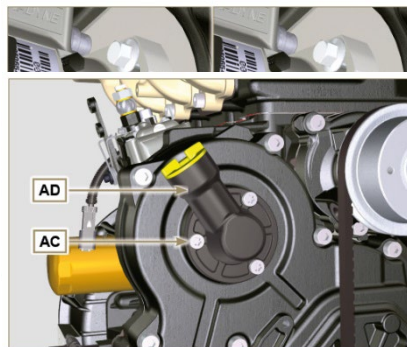


Fig 6.12

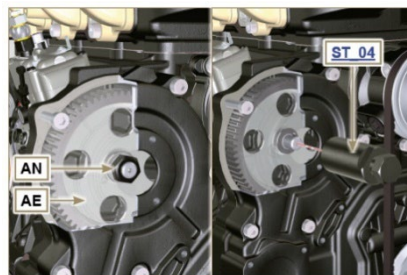


Fig 6.13

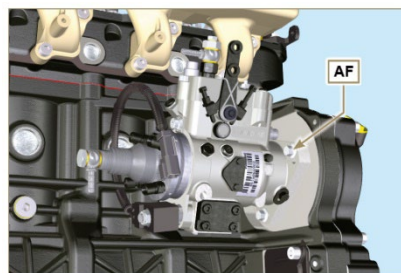


Fig 6.14

- Be careful that the nut **AN** does not fall into the timing cover.

13. Screw the tool **ST_04** on the gear **AE**.
14. Loosen the screws **AF**.

15. Tighten the screw of tool **ST_04** to disconnect the injection pump **AG** from the high pressure pump control gear **AE**.
16. Undo the screws **AF** and extract the injection pump **AG**.
17. Undo and remove the tool **ST_04**.

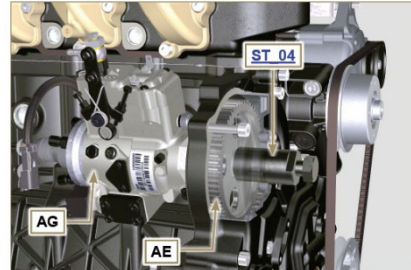


Fig 6.15

NOTE: Click on the right to play the procedure.

<https://www.youtube.com/embed/zqY-GF8IG0?rel=0>

6.1.6 Injection pump assembly

Warning

- Before assembling the new pump **AG**, make sure that plate **AB** can move freely and that fastening capscrews **K** are not loose (the pump sold as a spare part is supplied with the cylinder injection timing blocked **N° 1**).
- Ensure that the coupling surfaces on shaft **AP** and gear **AE** are free from impurities and lubrication residues.
- Remove the guard cap only when the pipes are reconnected.
- Do not remove the tool **ST_30**.

1. Mount the injection pump **AG**, inserting the shaft **AP** in the gear **AE**.

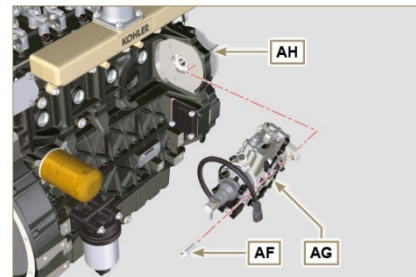


Fig 6.16

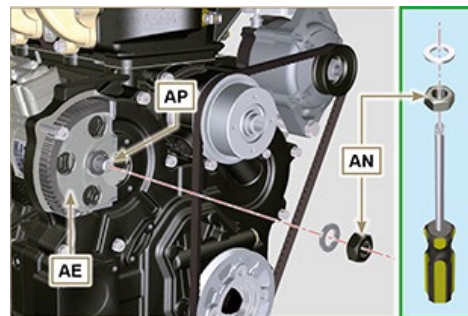


Fig. 6.17



Important

- Always change screws **AF** with new ones or apply **Loctite 270** to the threads.
2. Clamp the screws **AF** on the crankcase **AH** (tightening torque at **25 Nm**).
 3. Ensure that the correct advance value has remained unchanged, tighten nut **AN** on shaft **AP** (as shown in **Fig. 6.17**, is allowed the aid of

a screwdriver to guide the nut **AN** on the shaft **AP** in order to avoid the fall of it into the timing cover **AQ** - tightening torque at **70 Nm**).

4. Undo the capscrew **K** and shift the slotted plate **AB** in the direction of arrow **AA**.
5. Tighten screw **K** (tightening torque to **5.5 Nm**). The injection pump is unlocked.
6. Remove the tool **ST_30** and **ST_34**.

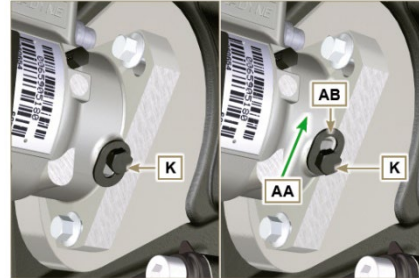


Fig 6.18

NOTE: Always replace the gasket **AJ** after each assembly.

7. Position the gasket **AJ** in the set on the flange **AD**.
8. Fix the flange **AD** on the crankcase **AQ** with the screws **AC** (tightening torque at **10 Nm**).

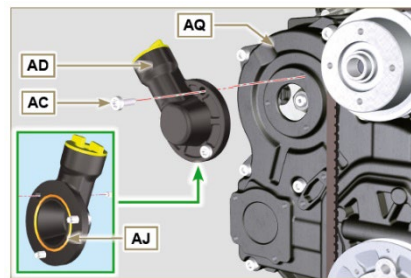


Fig 6.19

NOTE: Click on the right to play the procedure.

<https://www.youtube.com/embed/RJLCkTqlczU?rel=0>

6.1.7 Injector assembly



Important

- To prevent damaging the injection system, the protection caps ([Par. 2.9.7](#)) must be removed during assembly.

1. Lubricate the gaskets **U**, **T**, **S** and fit them on the injector **Z**.

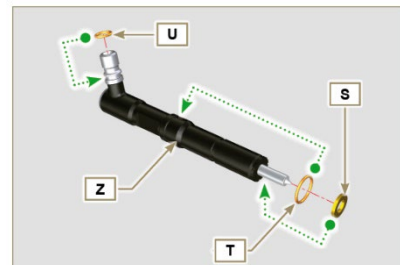


Fig 6.20

2. Fit the injector **Z** in the sleeve **V**.

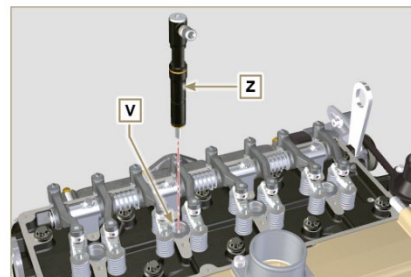


Fig 6.21

3. Assemble the parts **P**, **Q**, **R** and fit the parts so assembled on the injector **Z**.

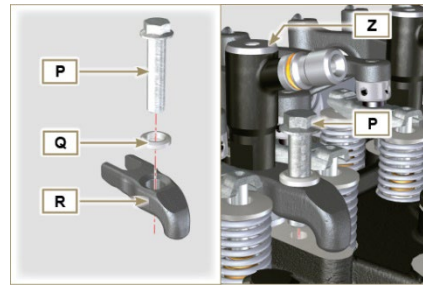


Fig 6.22

4. Insert tool **ST_51** on the injectors junctions **Z** (detail **X1**).
5. Tighten the screw **P** (tightening torque to **20 Nm**)

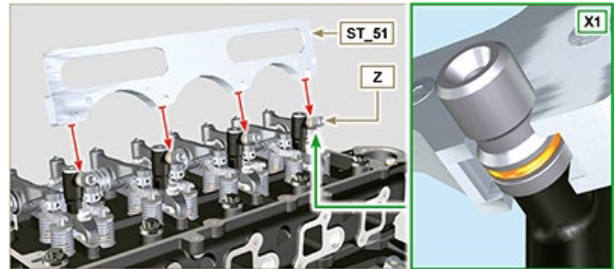


Fig 6.23

NOTE: Click on the right to play the procedure.

<https://www.youtube.com/embed/Kcv-3Edask?rel=0>

6.1.8 Assembly of the injector return pipes

1. Position the tube **N** on the injectors **Z**, and tighten screws **M** (tightening torque to **14 Nm**).

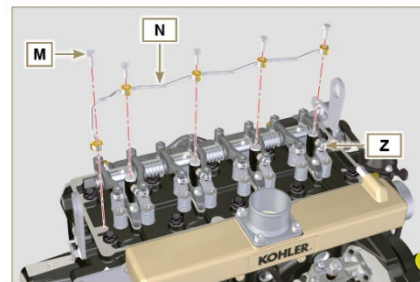


Fig 6.24

6.1.9 Assembly Rocker arm cover



Important

- The gasket **AM** between the rocker arm cover and the cylinder head must always be replaced every time it is disassembled.

1. Position the two guide pins **ST_17** before mounting the rocker arm cover.
2. Position the gasket **AM** on the head **AL** respecting the fastening screw holes **L**.
3. Attach the rocker arm cover **C** on the head **AL** with the screw **L** adhering to the tightening sequence shown in **Fig. 6.27**

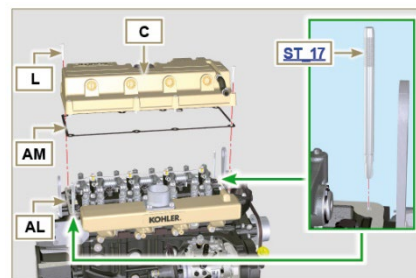


Fig 6.25

(KDI 1903 M) or Fig. 6.28 (KDI 2504 M)
(tightening torque to **10 Nm**).

4. Connect pipe **H** and tighten the clamp **G**.



Important

- Always replace the gaskets **AK** after each disassembly ([ST_36](#)).

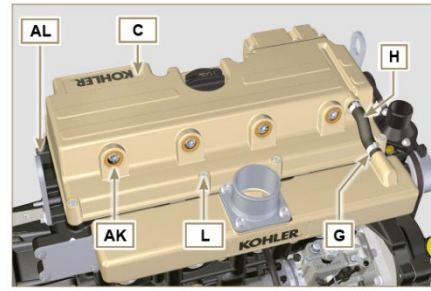


Fig 6.26

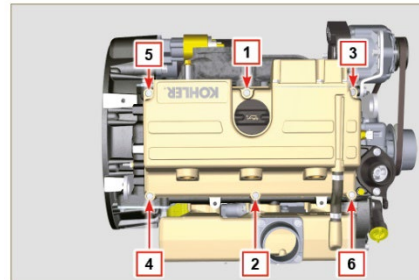


Fig 6.27

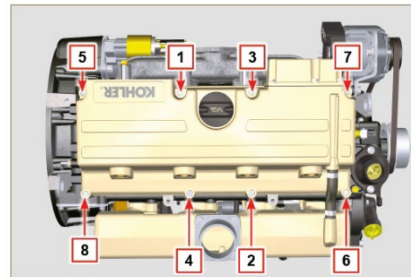


Fig 6.28

6.1.10 Installation of the fuel injector pipes (pump injector/injectors)

1. Position pipes **D** on the injectors and on the injector pump.



Important

- Tighten the nuts **E** and **F** manually, without clamping them.
2. Tighten the nuts **E** and **F** (tightening torque at **25 Nm**).
 3. Reinstall the retainers **C** of the hoses **D**.
 4. Fix the plate **B** by using screws **A** (tightening torque to **10 Nm**).

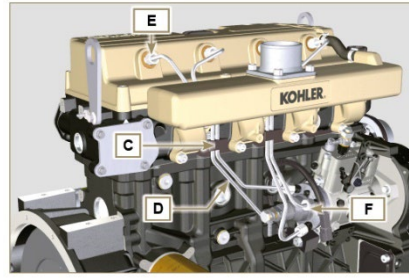


Fig 6.29

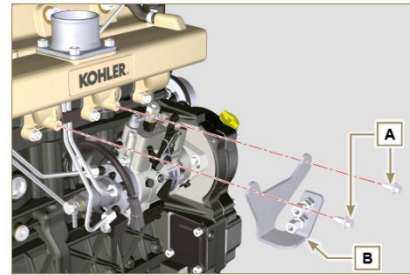


Fig 6.30

6.2 Coolant pump replacement

6.2.1 Disassembly

1. Perform the operations described in [Par. 5.1](#).



Important

- Before proceeding with operation, read [Par. 3.3.2](#).
 - The pump **G** isn't repairable.
2. Loosen the screws **A** and **B**.
 3. Push the alternator **C** in the direction of the arrow **D** and remove the belt **E**.
 4. Loosen the screws **F** and remove the pump **G** and relative gasket **H**.

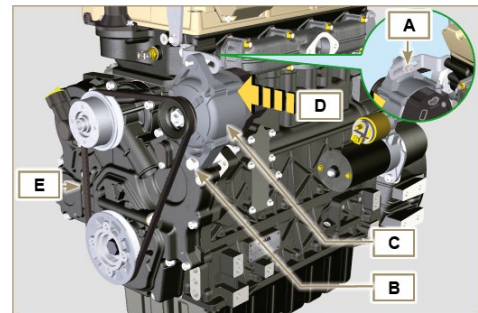


Fig 6.31

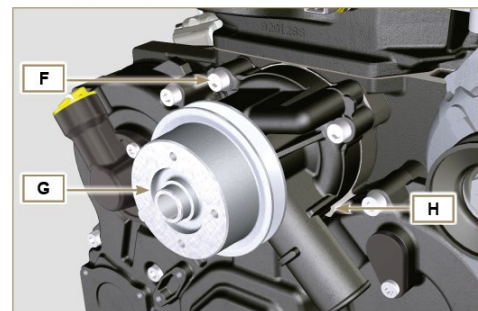


Fig 6.32

6.2.2 Assembly



Important

- Always replace the gaskets **H**, after each disassembly.
 - Always replace the belt **E** after each assembly.
1. Fit the coolant pump **G** with the screws **F** interposing the new gasket **H** (tightening torque at **25 Nm**).
 2. Insert the belt **E** on the pulleys **L**.
 3. Push the alternator **C** in the direction of the arrow **D**.
 4. While tensioning the alternator **C**, first clamp screw **A** (tightening torque at **25 Nm**) and then screw **B** (tightening torque at **69 Nm [thread M10] - 40 Nm [thread M8]**).
 5. Check the tension of the belt **E** with the instrument (**DENSO BTG-2**), positioning it in point **p** (the tension must be between **200 and 230 N**)
 6. If the tension values do not correspond, tighten screws **A** and **B**, then repeat operations **3, 4 and 5**.

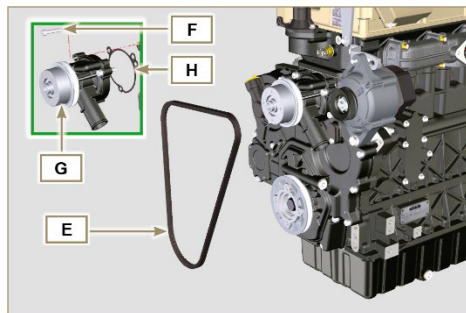


Fig 6.33

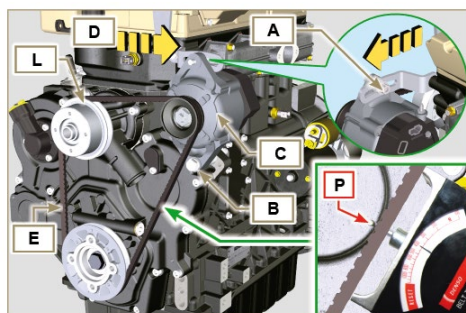


Fig 6.34

6.3 Replace the crankshaft pulley

6.3.1 Disassembly



Important

- Before proceeding with operation, read [Par. 3.3.2](#).

NOTE: Perform the operations described in [Par. 6.1.5 steps 2 and 3](#).

1. Position the crankshaft with the 1st cylinder in TDC, reference **A**.
2. Remove the alternator belt following steps **2 and 3** ([Par. 6.2.1](#)).

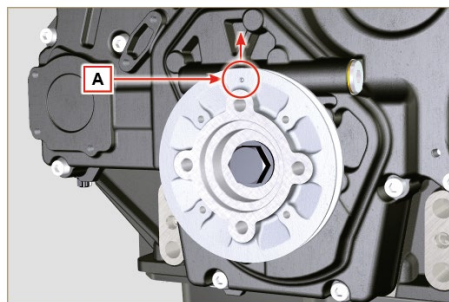
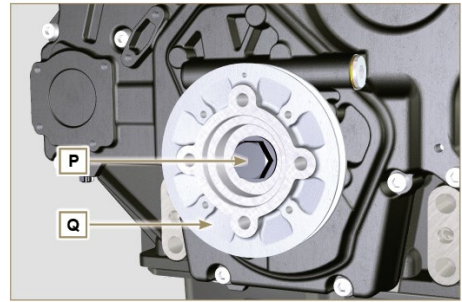


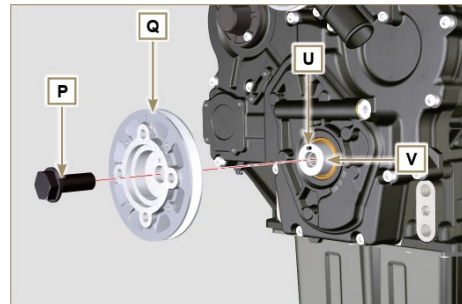
Fig 6.35

3. Undo the screw **P** (clockwise) and remove the pulley **Q**.


Fig 6.36

6.3.2 Assembly

1. Check that the pin **U** is mounted properly on the crankshaft **V**.
2. Insert the pulley **Q** on crankshaft **V** respecting the reference of the pin **U**.
3. Apply **Molyslip** grease on the screw thread **P**.
4. Fit the pulley **Q** with the screw **P** (tightening torque **360 Nm**) and remove the tool **ST_34**.


Fig 6.37

6.4 Oil pump replacement



Important

- Before proceeding with operations, read **Par. 3.3.2**.
- The oil pump is not repairable.

6.4.1 Coolant pump disassembly

1. Perform the operations described in **Par 6.2.1**.

6.4.2 Engine pulley disassembly

1. Perform the operations described in **Par 6.3.1**.

6.4.3 Timing system crankcase disassembly



Important

- Perform the operations described in [Par. 5.2](#).
1. Make sure that the reference pin **A** is facing upwards.
 2. Undo the screws **B** and remove the timing system crankcase **C**.

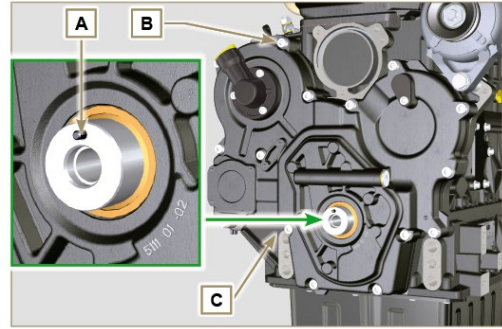


Fig 6.38

6.4.4 Oil pump disassembly

1. Undo the screws **D** and remove the group pump **E** from the timing system crankcase **C**.
2. Remove the rotors **F** and **G** from the oil pump crankcase **E**.

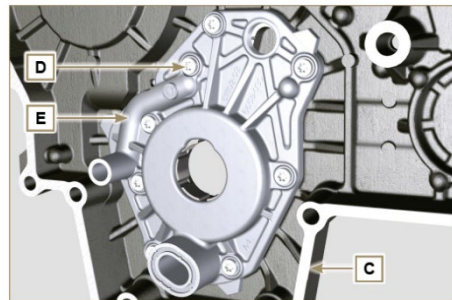


Fig 6.39

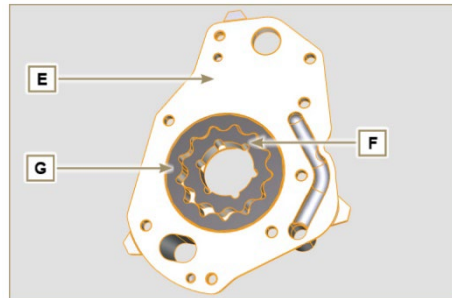


Fig 6.40

6.4.5 Oil pump assembly



Important

- Carry out the checks described in [Par. 8.7](#) prior to assembly.
1. Check that all surfaces in contact between **F, G, H, E** and **C** are free from impurities - scratches - dents.
 2. When assembling, do not use any type of gasket between **E** and **C**.
 3. Thoroughly lubricate the seat of the rotors **H** on the oil pump crankcase **E** and the two rotors **F** and **G**.

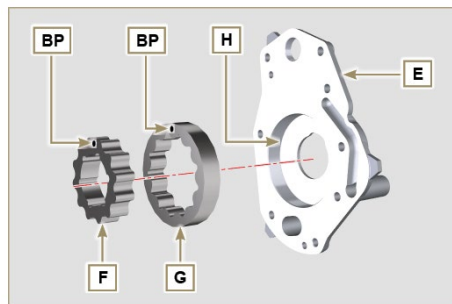


Fig 6.41

4. Within housing **H** insert the 2 rotors (in sequence) **G** and **F**, observing the references **BP** as described in figure (or refer to **Par. 2.10.2**).
5. Check that the 2 pins **L** are inserted properly in the timing system crankcase **C**.
6. Position the oil pump carter **E** using the reference pins **L**.
7. Clamp the oil pump carter **E** with the screws **D** (tightening torque **10 Nm - ST_06**).

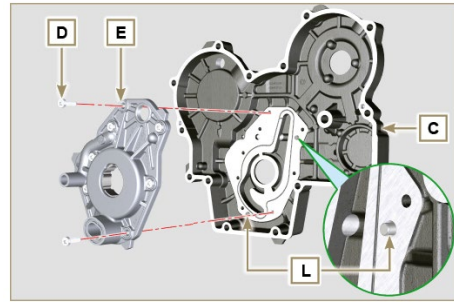


Fig 6.42

6.4.6 Timing system crankcase assembly



Important

- Always replace the oil seal **J** after each assembly.
- Always replace the gasket **P** after each assembly.
- To prepare the surface of the **K** plane for the new application of the sealant, it must be cleaned through the use of:
 - initially **Loctite SF 7200**
 - subsequently **Loctite SF 7063**
 Avoid any contact with the **K** plane and be careful not to compromise the cleaning performed.

1. Lubricate the lip of the oil seal **J**.
2. Distribute a bead of **Loctite 5188**, about 1mm thick, on the surfaces **K** of the crankcase **C**.
3. Make sure that the key **M** (**Fig. 6.44**) is inserted properly on the crankshaft and that it is facing upwards.
4. Check that the 2 pins **N** are inserted properly in the timing system crankcase **C**.

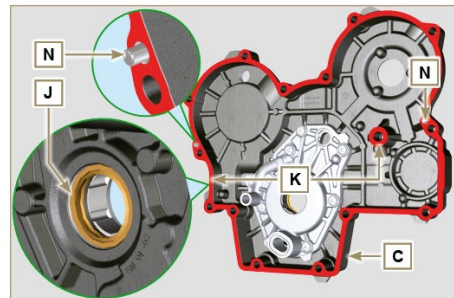


Fig 6.43

5. Lubricate and insert the gasket **P** in the seat of the oil pump **Q**.
6. Tighten the tool **ST_10** on the crankshaft.
7. Position the crankcase **C** on the base, using the reference pins **M**, inserting the oil pump **Q** on the crankshaft.

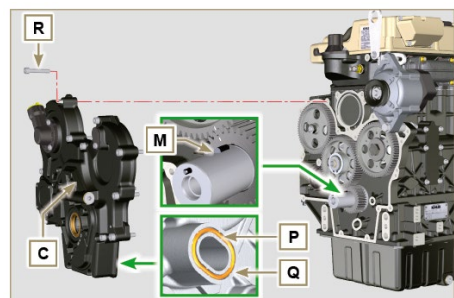


Fig 6.44

- Fit the timing system crankcase **C** with the screws **R** observing the indicated clamping sequence (tightening torque at **25 Nm**).

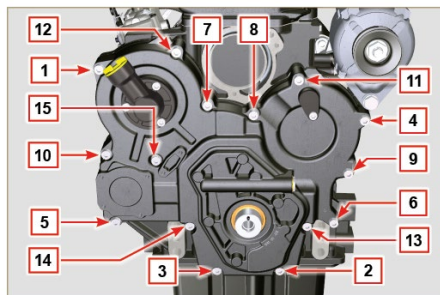


Fig 6.45

6.4.7 Crankshaft pulley assembly

- Perform the operations described in [Par 6.3.2](#).

6.4.8 Coolant pump assembly

- Perform the operations described in [Par 6.2.2](#).

6.5 Oil pressure valve replacement

6.5.1 Disassembly



Important

- Before proceeding with operation, read [Par. 3.3.2](#).
- Undo the cap **A**.
 - From the crankcase **D**, remove the spring **B**.
 - Remove the valve piston **C** using a magnet.

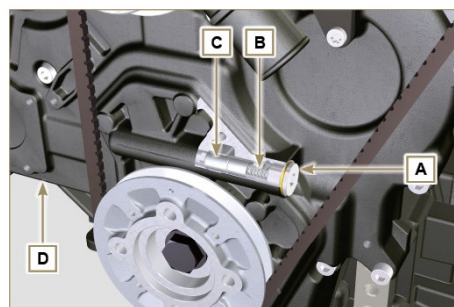


Fig 6.46

6.5.2 Assembly



Important

- Carry out the checks described in [Par. 8.7.3](#) prior to assembly.
 - Always replace the gasket **F** after each assembly.
- Lubricate the piston **C** and fully insert it in the seat **E**.
 - Insert the spring **B** in the piston.
 - Mount the gasket **F** on cap **A**.
 - Clamp the cap **A** on the crankcase **D** (tightening torque at **50 Nm**).

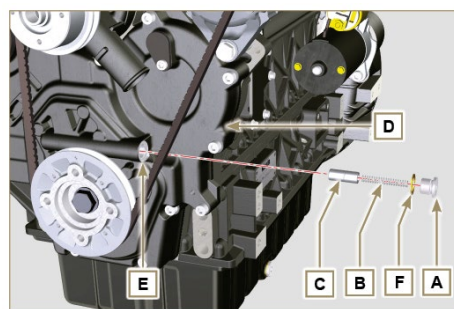


Fig 6.47

6.6 Oil filter replacement

6.6.1 Disassembly

Important

- Before proceeding with operation, read [Par. 3.3.2](#).
 - Perform the operations described in [Par. 5.2](#).
1. Unscrew the cartridge **A**.

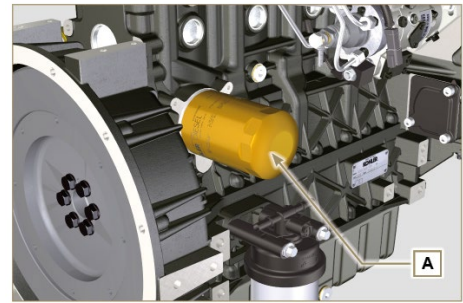


Fig 6.48

6.6.2 Assembly

Important

• In the event of mounting the fitting **U** on the crankcase **S** (tightening torque at **1 5 Nm + Loctite 2701**).

1. Check that the surface **Q** on crankcase **S** are free from impurities.
2. Screw the cartridge **A** on the fitting **U** (tightening torque at **15 Nm**).

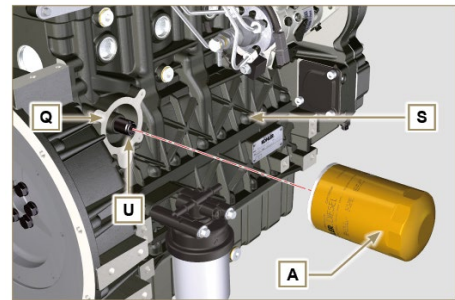


Fig 6.49

6.7 Fuel filter replacement



Important

- Before proceeding with operation, read [Par. 3.3.2](#)



Warning

- In case of low use replace it 12 months.
1. Procure a suitable container to collect the fuel.
 2. Rotate the filter **A** to take it to the unlocked position and remove it.
 3. Lubricate the gasket **C**.
Assemble the filter **A** on the support **B** and rotate it until reaches the lock position.



Important

- Do not fill the new cartridge **A** with fuel.
4. Turn the key on the control panel to the **ON** position. The electric pump **D** sends fuel to the filter and then the injection pump **E**.

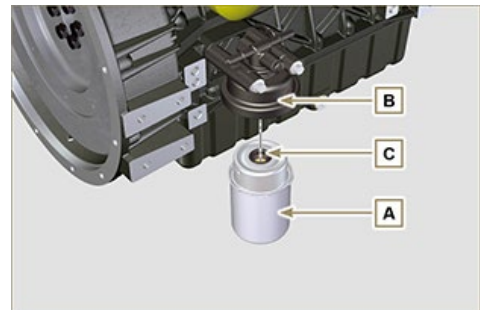


Fig 6.50

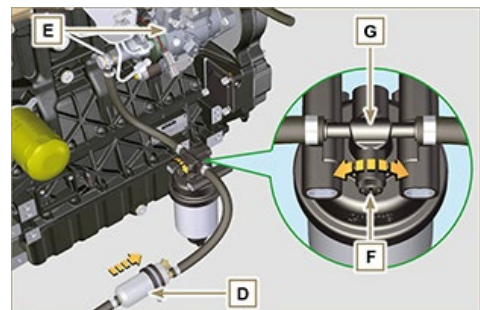


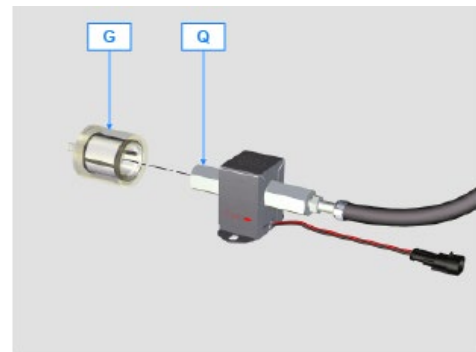
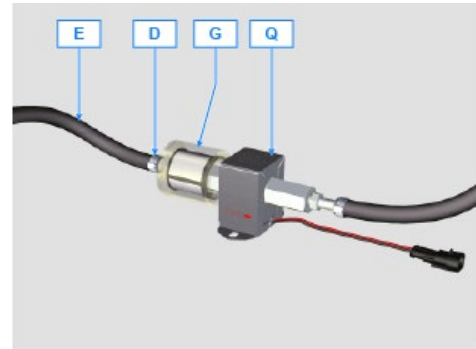
Fig 6.51

5. Loosen the air bleeding screw **F** on fuel filter bracket **B**.
The air inside the circuit and the filter will begin to escape from the screw **G**.
6. Tighten the bleeding screw **F** (tightening torque of **1.5 Nm**) when the fuel begins to flow.



Warning

- Check that the fuel supply pump filter is present, and replace if necessary.
1. Release the clamp **D**.
 2. Demount the hose **E**.
 3. Unscrew the filter **G** from the pump **Q**.
-
4. Screw the new filter **G** onto the pump **Q** (tightening torque **20 Nm**).
 5. Connect the hose **E** to the filter **G** and fasten with the clamp **D**.



NOTE: Click on the icon to play the procedure.

https://www.youtube.com/embed/mek_o2s8_-U0?rel=0

7 INFORMATION FOR DISASSEMBLY

7.1 Recommendations for disassembly



Important

- The mark (↔) after the title of a paragraph, indicates that the procedure is not required in order to disassemble the engine, however the procedures are featured in order to illustrate the disassembly of components.
- The operator should prepare all equipment and tools in order to enable him to carry out the operations correctly and safely.
- Before disassembly, perform the operation described in [Chap. 5](#).
- Before proceeding with operation, carefully read [Chap. 3](#).
- In order to operate safely and easily, we recommend positioning the engine on a rotating stand for engine overhauling.
- Seal all injection component unions as illustrated in [Par. 2.9.7](#) during assembly.
- Protect all disassembled components and coupling surfaces subject to oxidation with lubricant.
- Where necessary, reference to special tools to use during disassembly operations is indicated (es. [ST_05](#)), identified in [Tab. 13.1 - 13.2 - 13.3](#).

7.2 Electric components disassembly

7.2.1 Electric wiring

1. Disconnect and remove the engine wiring.

NOTE: refer to [Par. 2.13.1.3](#) to disconnect all connectors.

7.2.2 Starter motor



Important

- The motor is not repairable.
1. Undo the screws **A** and remove the starter motor **B**.
 2. Mount the tool [ST_34](#) in the seat of the starter motor **P** and fit it with the two starter motor fixing screws to block the flywheel.

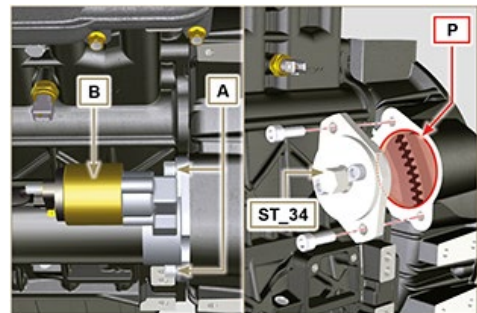


Fig 7.1

7.2.3 Belt and alternator

1. Loosen the screws **C** and **D**.
2. Push the alternator **E** in the direction of the arrow **F**.
3. Remove the belt **G** from the pulleys.



Important

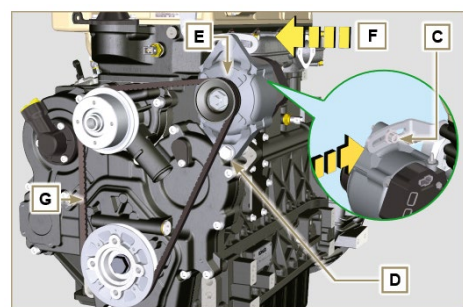


Fig 7.2

- The belt must always be replaced every time it is disassembled, even if it has not reached the scheduled hours for replacement
4. Undo the screws **C and D** and remove the alternator **E**.

7.2.4 Sensors and switches



Important

- After disassembly, protect the sensors suitably against knocks, dampness and any high temperature sources.
- The sensors and switches cannot be repaired, therefore they must be replaced in the event of anomalies.

7.2.4.1 Oil pressure switch disassembly (↔)

1. Unscrew and remove oil pressure switch **H**.

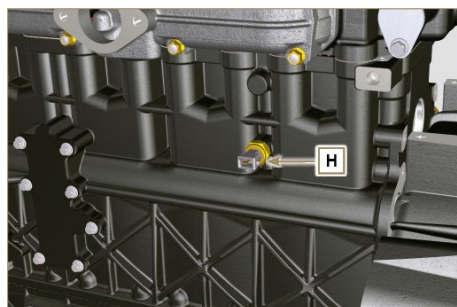


Fig 7.3

7.2.4.2 Coolant temperature sensor (↔)

1. Unscrew and remove the sensor **L**.

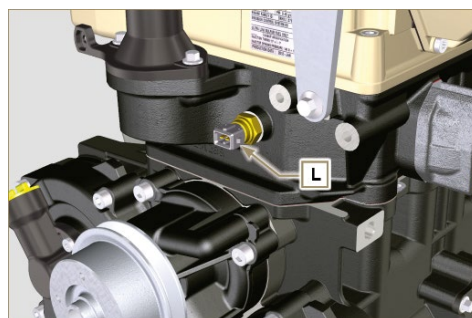


Fig 7.4

7.2.4.3 Fuel filter water detection sensor (↔)



Warning

- The fuel filter is not always installed in the engine.
- When disassembling the sensor **M**, use a suitable container to recover the fuel contained in the cartridge **N**.

1. Unscrew the sensor **M** from the cartridge **N**.

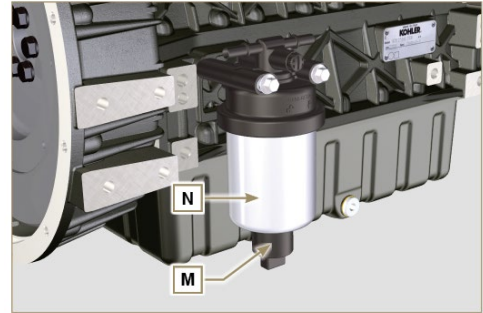


Fig 7.5

7.3 Exhaust manifold disassembly

1. Undo the nuts **A** and remove the manifold **B** and the metallic gaskets **C**.
2. Close the openings and manifolds to prevent foreign bodies from entering.

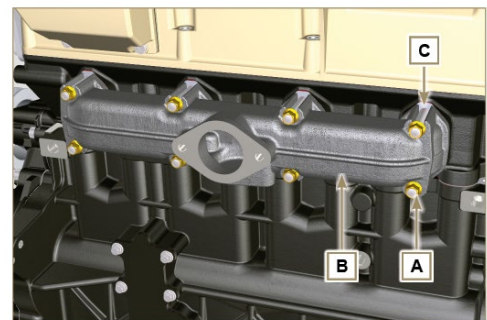


Fig 7.6

7.4 Coolant recirculation components disassembly

7.4.1 Coolant recirculation components disassembly



Important

- The pump **B** is not repairable
1. Undo the screws **A** and remove the water pump unit **B** with its gasket **C**.



Fig 7.7

7.4.2 Thermostatic valve

1. Undo the screws **D** and remove the thermostatic valve cover **E**.
2. Remove the thermostatic valve **F** and its gasket.



Important

- Always replace the gasket **G** every time it is disassembled.
3. Check that the air bleeding hole is not clogged or blocked ([Par. 2.11.3](#)).

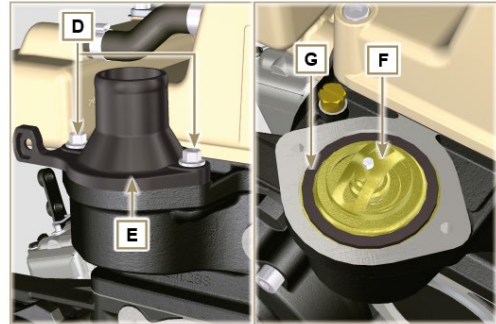


Fig 7.8

7.5 Crankshaft pulley disassembly

NOTE: Perform the operations described in [Par. 6.1.5 points 2 and 3](#).

1. Undo the screw **A** (clockwise - as seen from the timing system side - Ref. [A Par. 1.3](#)) and remove the pulley **B**.

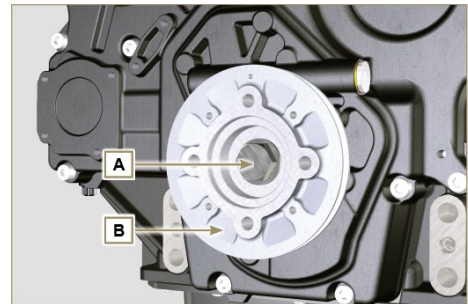


Fig 7.9

7.6 Lubrication circuit disassembly

7.6.1 Oil overpressure valve (↔)

1. Undo the cap **A**.
2. Remove the spring **B**.
3. Remove the valve piston **C** using a magnet.

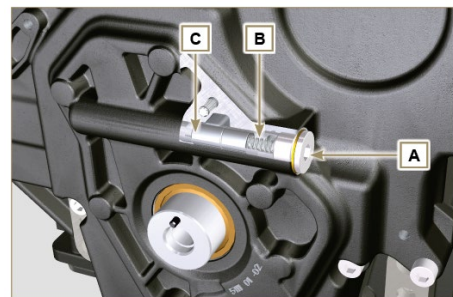


Fig 7.10

7.6.2 Timing system semi-crankcase oil filling flange (↔)

1. Undo the screws **G** and remove the oil filling flange **E** (**ST_06**).
2. Remove the gasket **F**.

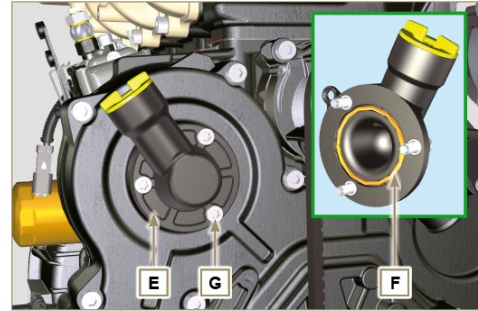


Fig 7.11

7.6.3 Timing system

1. Make sure that the crankshaft with the 1st cylinder is at TDC.
2. Undo the screws **X**.
3. Remove the timing system crankcase **H**.

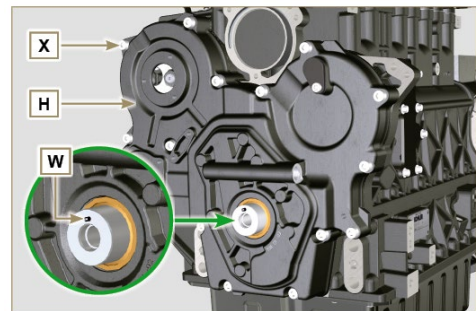


Fig 7.12

7.6.4 Oil pump



Important

- The oil pump is not repairable.
1. Undo the screws **M** and remove the pump crankcase **N** from the crankcase **D** (**ST_06**).

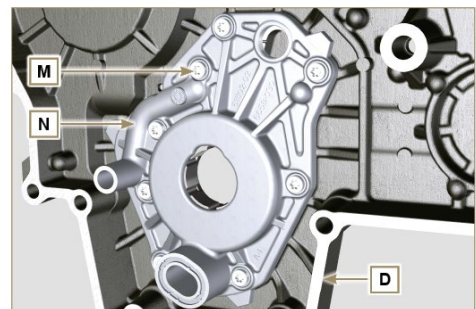


Fig 7.13

2. Remove the rotors **P** and **Q**.

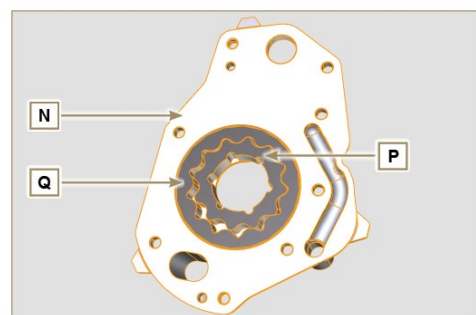


Fig 7.14

7.6.5 Oil filter

1. Unscrew and remove the cartridge **R**.



Warning

- Use a suitable container to recover any residue oil.

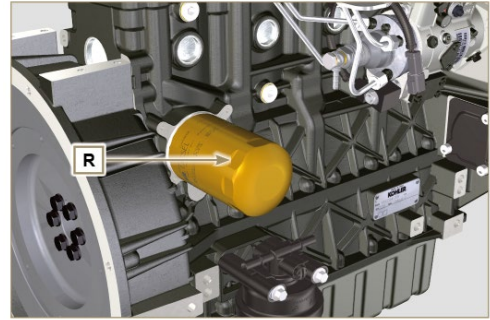


Fig 7.15

7.7 Intake manifold disassembly

1. Loosen clamp **A** and disconnect hose **B**.

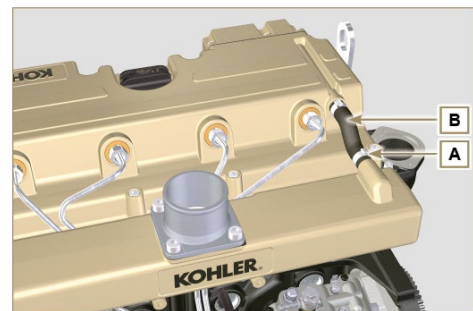


Fig 7.16

2. Undo the screws **C** and remove the manifold **D** together with the washer **E**.

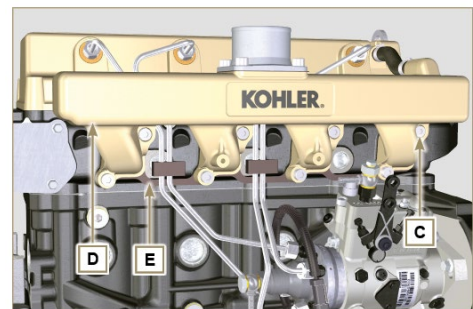


Fig 7.17

7.8 Fuel system disassembly



Important

- Seal all injection component unions as illustrated in [Par. 2.9.7](#).
- The fuel injection circuit undergoes high pressure, use safety protections as described in [Par 3.4.3](#).

7.8.1 Fuel injection pipes

1. Remove locking clips **A** from pipes **B**.
2. Loosen nuts **C** and **D** and remove pipes **B**.

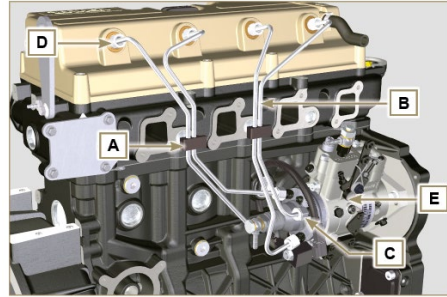


Fig 7.18

7.8.2 Rocker arm cover

1. Undo the screws **F** and remove the rocker arm cap **G**.

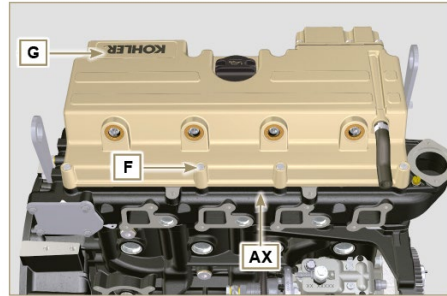


Fig 7.19

7.8.3 Fuel return pipes

1. Undo the screws **L** and remove hose **H**.

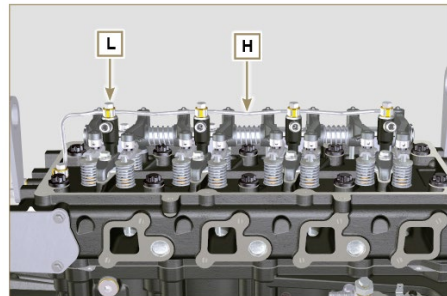


Fig 7.20

7.8.4 Injector

1. Undo the screws **P** and remove the washers **Q** and the brackets **M**.
2. Pull out the injectors **N**.

NOTE: Should you be unable to remove the injector (acting only on point **BC**), use an open-ended spanner (\varnothing **11 mm**), by applying small rotations to unblock the component. If the washer **K** is not found on the injector **N**, recover it from inside the injector sleeve **J**.

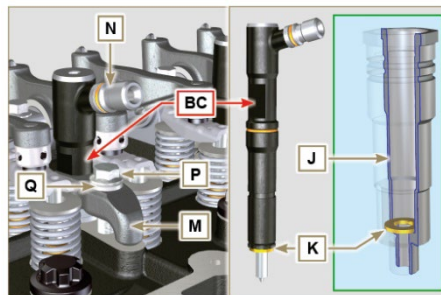


Fig 7.21

7.8.5 Injection pump



Important

- Before disassembling, carefully read [Par. 2.17.](#)
 - The injector pump cannot be repaired.
1. Carry on operations described in [steps 1-13](#) [Par. 6.1.5.](#)
 2. Undo the nut **S** and remove it together with the washer.
 3. Screw the unit **ST_04** on the gear **R**.
 4. Undo the screws **T**.
 5. Tighten the screw **U** of the unit in order to separate the injector pump **S** from the high pressure pump control gear **R**.

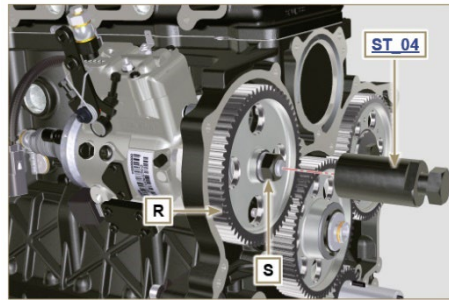


Fig 7.22

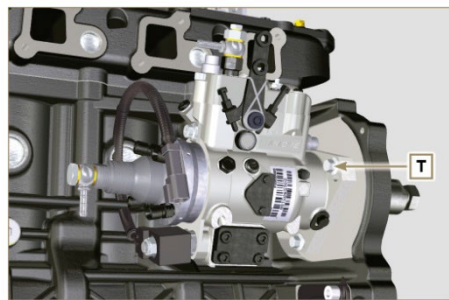


Fig 7.23

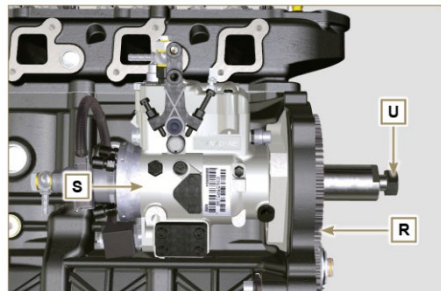


Fig 7.24

NOTE: Click by side to play the procedure.

https://www.youtube.com/embed/tQ9VHKE4u_0?rel=0

7.8.6 Fuel filter (↔)

NOTE: to disassemble the fuel cartridge, refer to operations 3 and 4 of [Par. 6.7.1.](#)

1. Undo the screws **V** and remove the filter support **W**.

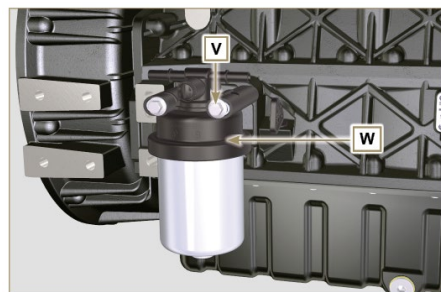


Fig 7.25

7.9 Timing system gear disassembly

1. Unscrew screws **C** and remove camshaft gear **D**.
2. Remove lock ring **A** and the shoulder ring **B**.
3. Remove the intermediate gear **L**.

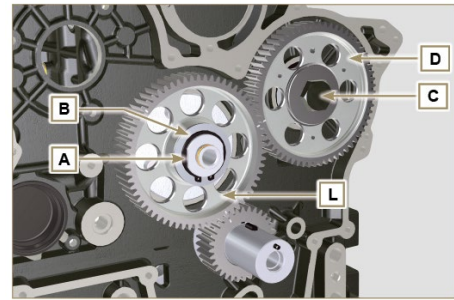


Fig 7.26

4. Undo the screws **F** and remove the intermediate gear support **G**.

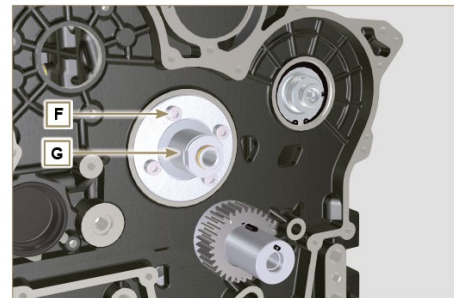


Fig 7.27

7.10 Flange unit disassembly

7.10.1 Flywheel



Important

- Leave the special tool **ST_34** for blocking the flywheel.
1. Only undo the screw **C** located upwards.
 2. Insert the tool **ST_09** in the seat of the screw **C** tightening it all the way.
 3. Undo the remaining screws **D**.

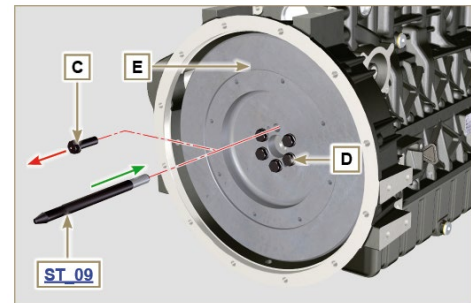


Fig 7.28



Danger

- The flywheel **E** is very heavy, pay utmost attention while removing it in order to prevent it from falling, with serious consequences for the operator.
4. Remove the flywheel **E**.
 5. Remove the tool **ST_09**.
 6. Remove the tool **ST_34** shown in **Fig. 7.1**.

7.10.2 Flange housing

1. Undo the screws **F** and remove the engine housing **G**.



Danger

- The housing **G** is very heavy, pay utmost attention while removing in order to prevent it from falling, with serious consequences for the operator.

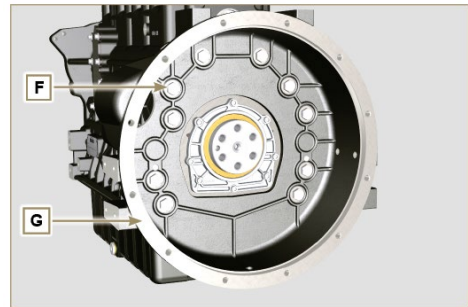


Fig 7.29

7.11 Cylinder head unit disassembly

7.11.1 Rocker arm pin

1. Undo the screws **A**.
2. Remove the rocker arm pin unit **B**.

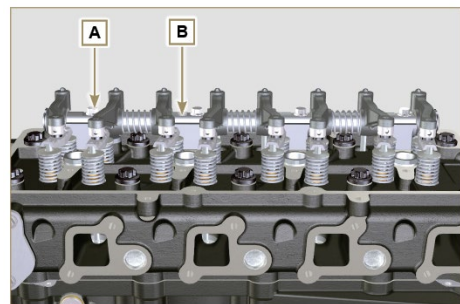


Fig 7.30

7.11.1.1 Rocker arm (↔)

1. Remove the retainer snap ring **C**.
2. Remove the shoulder rings **D**.
3. Remove the rocker arms **E** and springs.

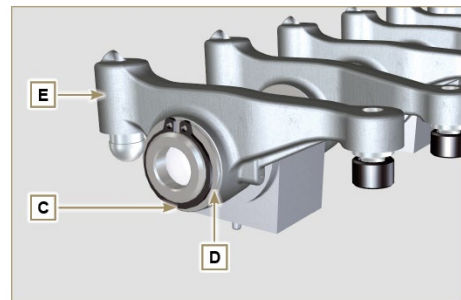


Fig 7.31

7.11.2 Rods and u-bolts

1. Remove the valve control U-bolts **H**.
2. Remove the rocker arm control rods **L**.

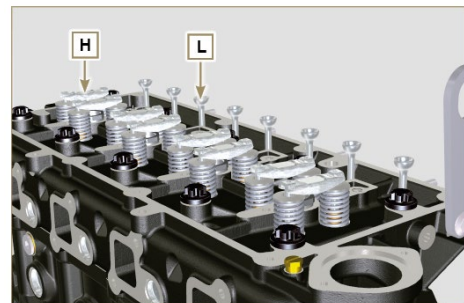


Fig 7.33

7.11.3 Cylinder head



Important

- Wait for the engine to reach ambient temperature before to remove the head in order to prevent deforming.
- The cylinder head fastening bolts **M** must be replaced every time they are disassembled.

1. Undo the bolts **M**.
2. Remove the cylinder head **N**.



Important

- Only use the eyebolts **AE** installed by **KOHLER** to move the cylinder head **Q**.

3. Remove the head gasket **P**.

7.11.3.1 Valves (↔)

1. Mount the tool **ST_07** on the head **Q** fixing it on one of the holes for fixing the rocker arm cover. **NOTE:** change the fixing hole according to the position of the valves to be removed.
2. Position the tool striker **ST_07** on the valve concerned as shown in the figure.
3. Push the lever of the tool **ST_07** downwards, in order to lower the valve plates **S** in the direction of the arrow **T**, using a magnet, remove the cotters **U**.

NOTE: repeat all the operations for all the valves concerned.

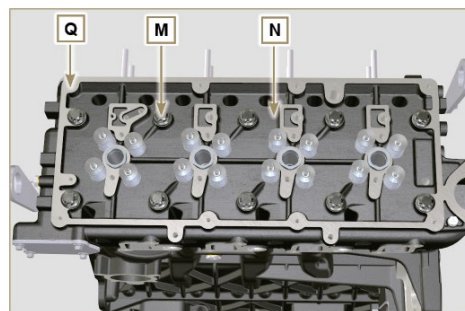


Fig 7.34

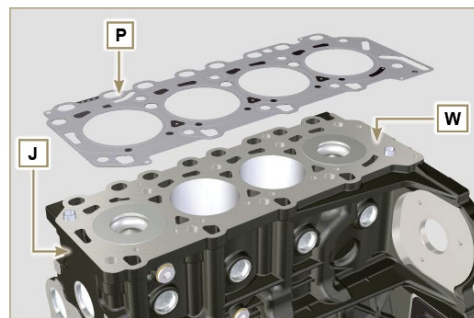


Fig 7.35

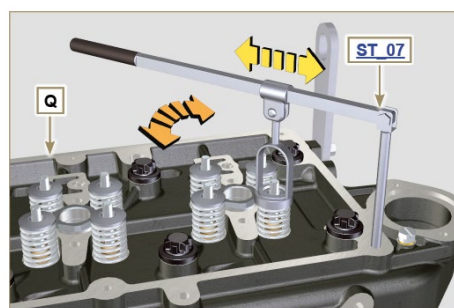


Fig 7.36

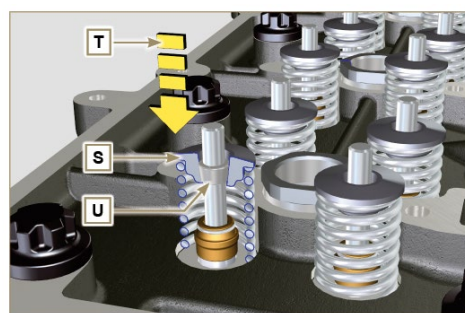


Fig 7.37



Important

- Before removing the valves, make some marks in their original position, in order to prevent confusing them when they are re-assembled, if they are not replaced.
4. Remove the valves **V**.

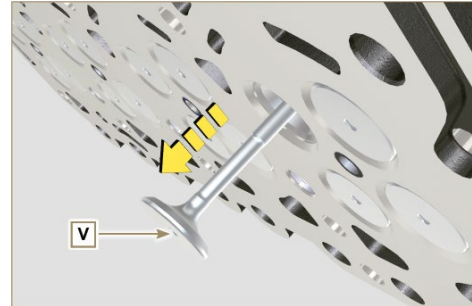


Fig 7.38

7.11.3.2 Injector sleeve (↔)

1. Unscrew and remove the sleeves **Z** from the head **Q**.
2. Remove the gaskets **AA** and **AB**.

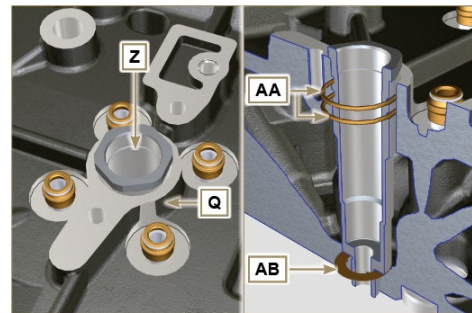


Fig 7.39

7.11.3.3 Valve steam gasket (↔)

1. Remove the oil seals **AC**.

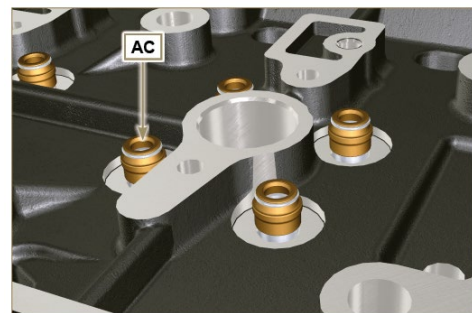


Fig 7.40

7.11.3.4 Lifting eyebolts (↔)

1. Undo the screws **AD** and remove the eyebolts **AE**.
2. Make the thorough washing the cylinder head **Q**.

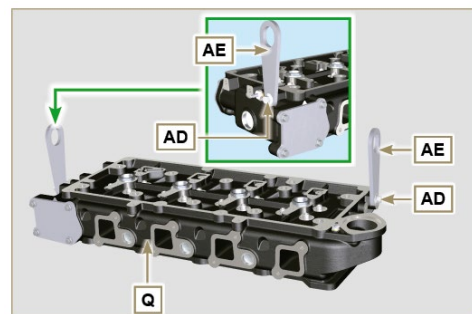


Fig 7.41

7.12 Oil sump unit disassembly

7.12.1 Oil sump

1. Undo the screws **A**.
2. Remove the oil sump **B** by inserting a plate in the areas indicated by the arrow **AA**.

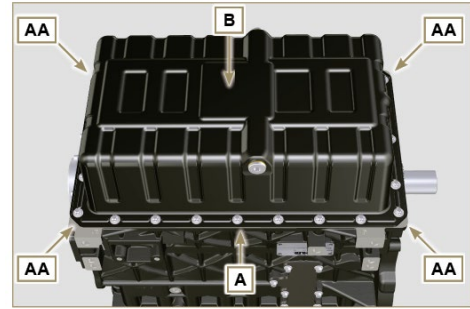


Fig 7.42

7.12.2 Oil intake pipe

1. Undo the screws **C** and remove the oil pipe **D**.

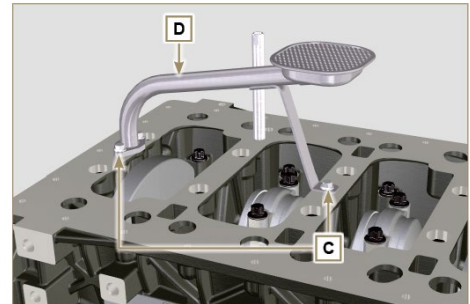


Fig 7.43

7.12.3 Oil vapour pipes (⇄)

1. Unscrew and remove the pipes **E**.

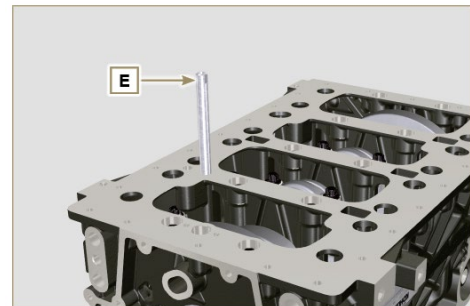


Fig 7.44

7.13 Engine block disassembly

7.13.1 Crankshaft gasket flange

1. Undo the screws **A**.
2. Remove the flange **B** and the gasket **C**.

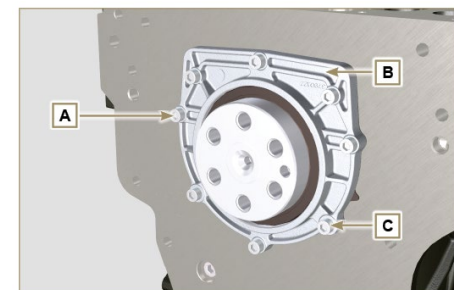


Fig 7.45

7.13.2 Piston unit/connecting rod



Important

- Mark some numerical references (cylinder n°) on the connecting rods, connecting rod caps **F1**, pistons and gudgeon pins to prevent unintentionally confusing the components not replaced during assembly. Failure to do this may result in engine malfunctions.
- References on connecting rod **M** and cap **F1** must only be carried out on a side in correspondence with **K1** and **K2**, as illustrated in **Fig. 7.46a**.

1. Screw the bolt **AM** temporarily.
2. Unscrew bolts **E1** and remove the connecting rod caps **F1**.

NOTE: coupling cap **F1** on the connecting rod can be carried out with centring taper pins (**Fig. 7.46b**) or broken (**Fig. 7.46c** - without centring taper pins).

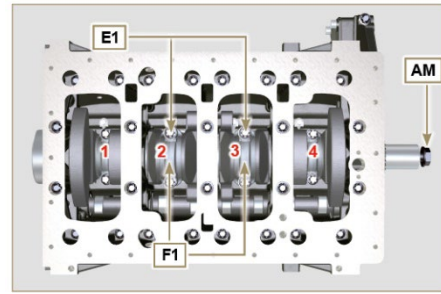


Fig 7.46



Fig. 7.46b

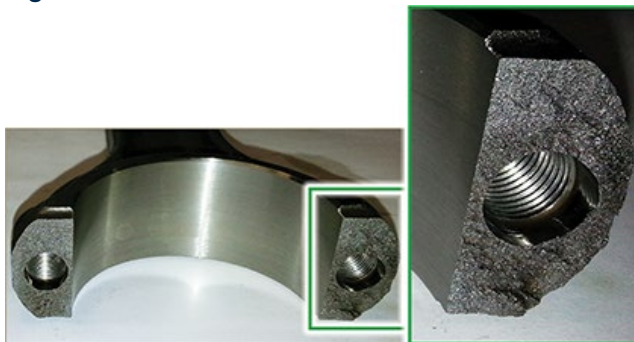


Fig. 7.46c

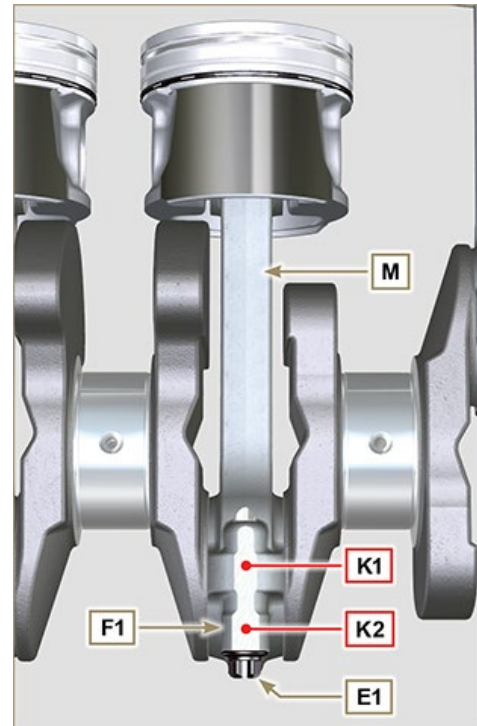


Fig 7.46a

3. Pull out the connecting rod - piston assembly from position **2 and 3** by manually applying pressure on the connecting rod big end **L** in the direction of arrow **AK**.
4. Couple the connecting rod big end caps **L** with the relevant piston and connecting rod unit **M**.
5. Turn capscrew **AM** and rotate the crankshaft by 180°.
6. Repeat points **2 to 5** to disassemble the connecting rod-piston assembly to position **1 and 4**.



Warning

- The connecting rod half-bearings **Z** are made of special material. Therefore, they must be replaced every time they are removed to prevent seizures.

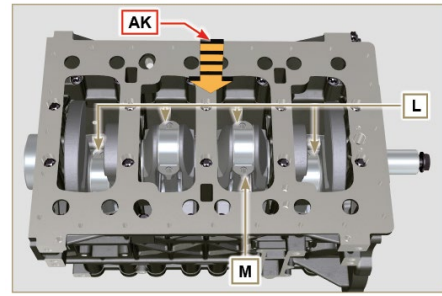


Fig 7.47

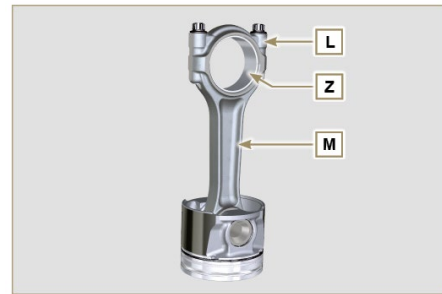


Fig 7.48

3 Cylinders

7.13.3 Lower semi-crankcase

3 CYLINDERS

1. Undo capscrews **E** and **F** by following the order indicated in the figure.
2. Remove the lower semi-crankcase **D** and store it in a suitable container for washing.

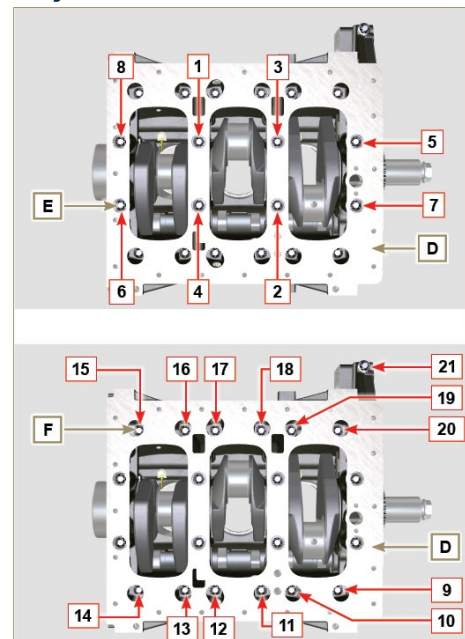


Fig 7.49

4 CYLINDERS

1. Undo capscrews **E** and **F** by following the order indicated in the figure.
2. Remove the lower semi-crankcase **D** and store it in a suitable container for washing.

4 Cylinders

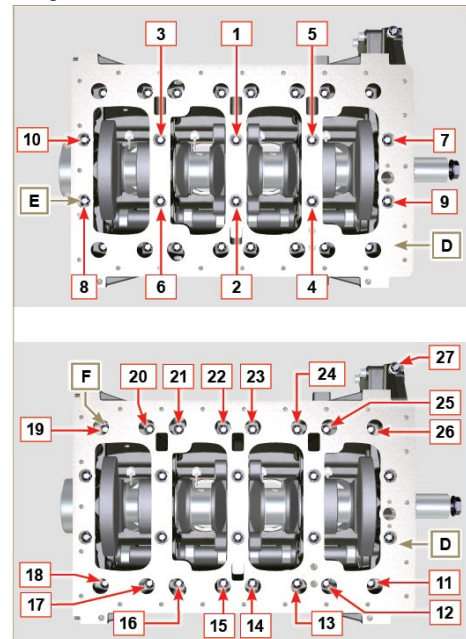


Fig 7.50

7.13.4 Crankshaft

Remove:

1. Crankshaft **G**.
2. The four shoulder semi-rings **H**.

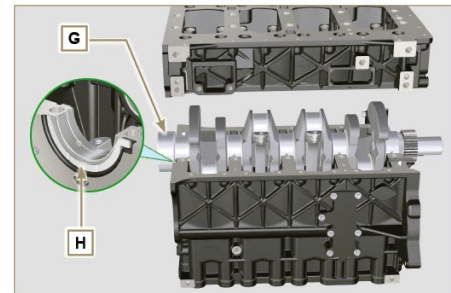


Fig 7.51

7.13.5 Piston (↔)

1. Remove the retainer ring **N**.
2. Remove the pin **P** to separate the piston **Q** from the connecting rod **R**.



Important

- If they are not replaced, keep the components together (connecting rod - piston - gudgeon pin) by using references in order to prevent them from getting mixed up during assembly.

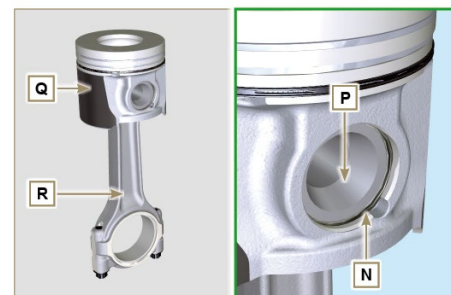


Fig 7.52

7.13.5.1 Rings (⇄)

1. Remove the seal rings **S**.

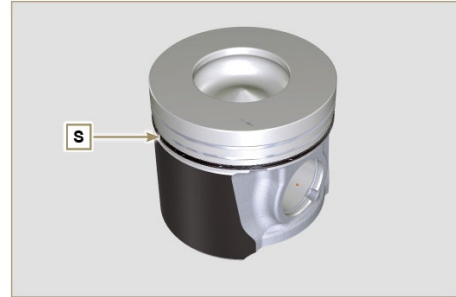


Fig 7.53

7.13.6 Breather room closing cover (⇄)

1. Undo the screws **AE** and remove the cover **AF**.

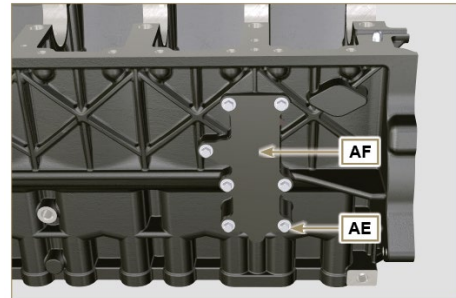


Fig 7.54

7.13.7 Camshaft

1. Remove the retainer ring **V**.
2. Extract the camshaft **W** from the upper crankcase **AB**.

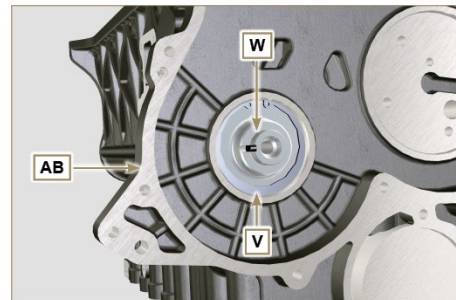


Fig 7.55

7.13.8 Camshaft tappets

1. With a magnet, remove the tappets **AA** from the upper semi-crankcase **AB**.

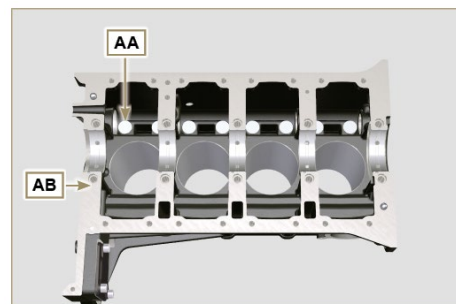


Fig 7.56

7.13.9 Crankshaft bushings

1. Remove the crankshaft bushings **AC** from the upper semi-crankcase **AB**.



Important

- The crankshaft half-bearings **AC** are made of special material. Therefore, they must be replaced every time they are removed to prevent seizures.

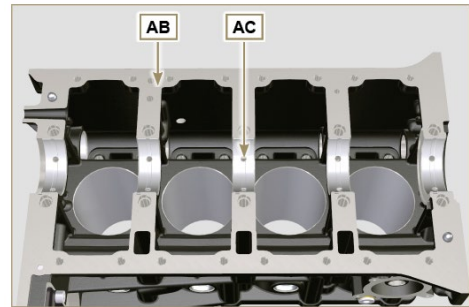


Fig 7.57

2. Remove the crankshaft bushings **AF** from the lower crankcase **D**.

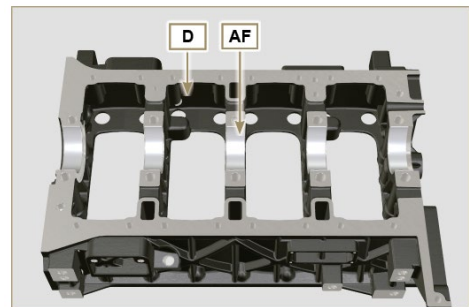


Fig 7.58

7.13.10 Cover 3 at PTO (↔)

1. Undo the screws **AG**.
2. Remove the cover **AH** and the gasket **AL**.

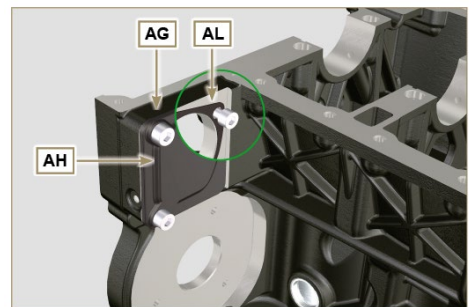


Fig 7.59

8 INFORMATION ABOUT OVERHAULING

8.1 Recommendations for overhauls and tuning

- The information is laid out in sequence, according to operational requirements, and the intervention methods have been selected, tested and approved by the manufacturer's technicians.
- This chapter describes procedures for checking, overhauling and tuning units and/or individual components.

NOTE: To easily locate specific topics, the reader should refer to the analytical index or chapter index.

- Before any intervention, the operator should lay out all equipment and tools in such a way as to enable him to carry out operations correctly and safely.
- The operator must comply with the specific measures described in order to avoid errors that might cause damage to the engine.
- Before carrying out any operation, clean the units and/or components thoroughly and eliminate any deposits.
- Do not wash the components with steam or hot water. Use suitable products only.
- Do not use flammable products (petrol, diesel, etc.) to degrease or wash components. Use suitable products only.
- Apply a layer of lubricant over all surfaces of all disassembled components to protect them against oxidation.
- Check the integrity and state of wear of all disassembled components in order to ensure good working condition of the engine.
- When indicated, some components are to be replaced in pairs or together with other parts (e.g. crankshaft half-bearings/connecting rod, piston complete with rings and gudgeon pin, etc.).
- When indicated, some grinding operations are to be carried out in series (e.g. grinding of cylinders, crankpins, journals, etc.).

8.2 Crankcase

8.2.1 Oil line check

Use a pipe cleaner in access points **A, B, C, D, E** to clean the oil ducts of crankcase **G**. Use compressed air to eliminate any residues.

Replace and assemble the conical cap in hole **B** (**B1** if present - tightening torque at **30 Nm**) and caps in holes **D**, after having performed cleaning operations.

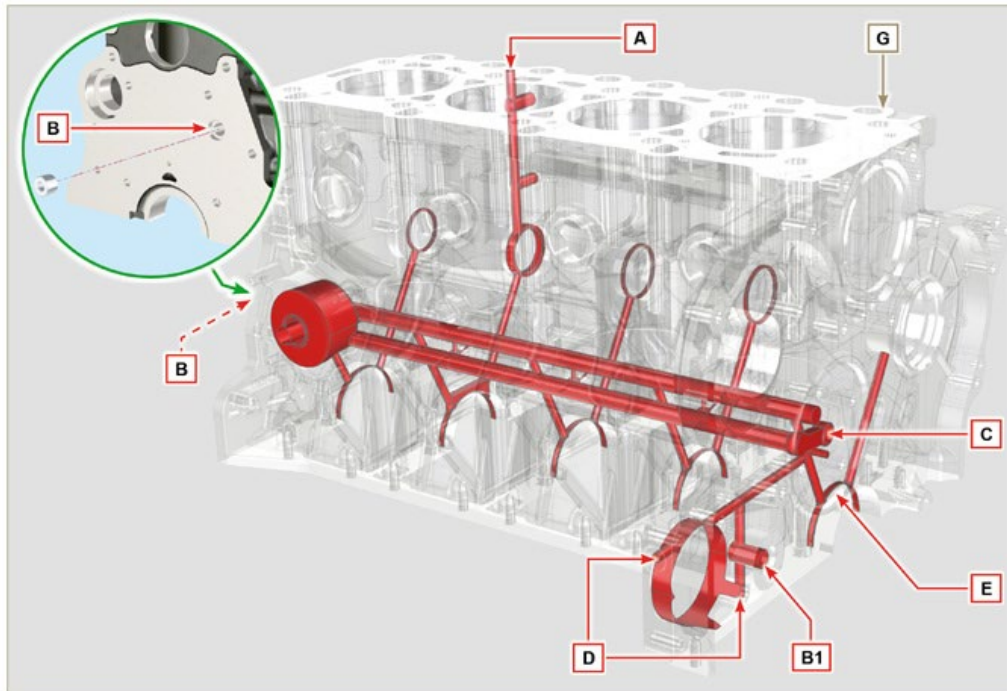


Fig 8.1

8.2.2 Cylinder check

Position crankcase **G** onto a workbench.

With a dial gauge, measure the diameter in correspondence to points **J-M-N** (Fig. 8.2) lengthwise and diagonally with regard to axis **H** of the crankshaft.

If ovalisation or wear detected in a single point in **J-M-N** is greater than +0.05 mm with regard to the value in **Tab. 8.1a**, you are required to perform grinding operations on all cylinders **F**.

Refer to **Tab. 8.1a** to establish the clearance value of cylinders subjected to grinding operations.



Important

- The grinding involved is of **+0.20, +0.50 e + 1 mm**.
- Cylinder grinding operations must observe **KOHLER SPECIFICATIONS - cod. ED0035612500**.
- Grinding must be strictly performed on all cylinders **F**.

Tab. 8.1a details the dimensional values of new components only.

- ⁽¹⁾ The increase of **+0.20mm**, may already be present on the engine.
- The increase of **+0.20mm** may already be present, no further adjustments can be made.

Tab 8.1a Grinding values

PISTON	Ø CILINDER (± 0.007 mm)	Ø PISTON (± 0.007 mm)	CLEARANCE VALUE (mm)
STD	88.010	87.950	0.046 - 0.074
+0.20 ⁽¹⁾	88.210	88.150	

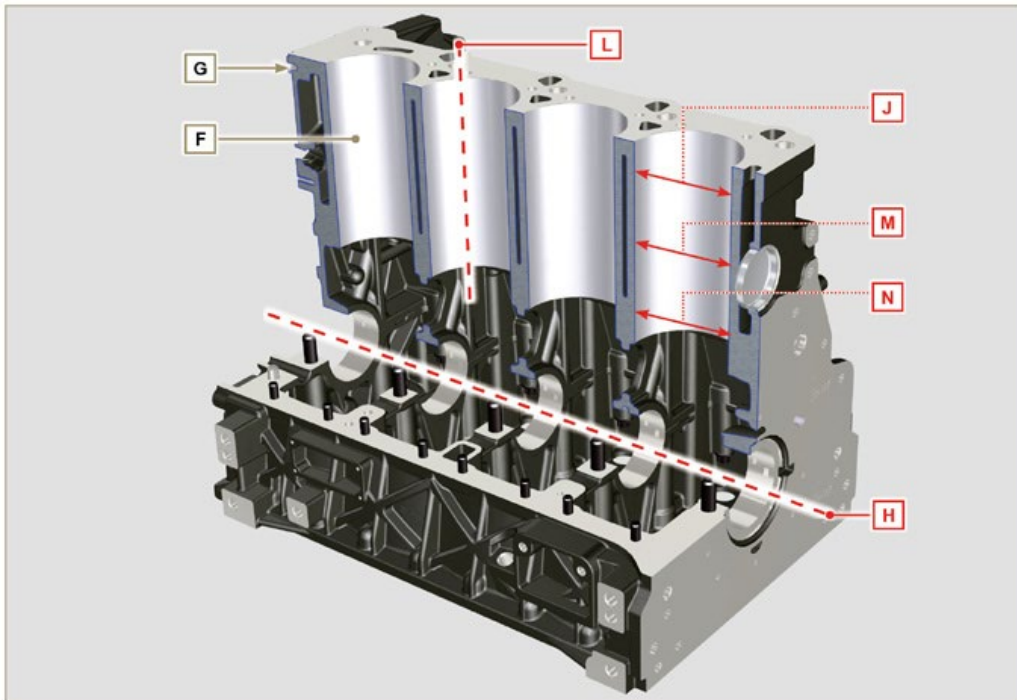


Fig 8.2

N.B.: if removing the Z2 hole closing cap, the new cap must comply with the MAX measurement of 1.5 mm from the surface G1.

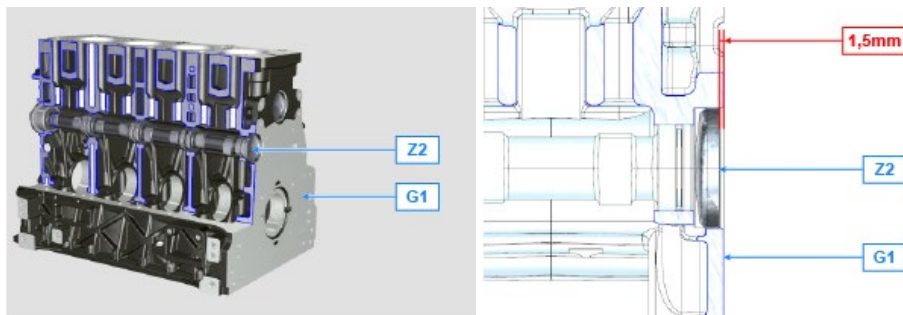


Fig 8.2a

8.2.3 Block Surface Flatness

Use a dial gauge to check if the cylinder head surface A1 is level.

The MAX value of allowable irregularity of surface A1 is:

- 0.10 mm on the entire area;
- 0.03 mm on an area of 100x100 mm.

Grinding of surface A1 is not permitted



Fig 8.2b

8.2.4 4-cylinder camshaft housing check

The camshaft housings only contain the timing system side bushing **Q**.

Use an internal dial gauge to measure the diameters of housings **X - W - K - Y - Z**.

With a micrometer, measure the diameters of gudgeon pins **X1 - W1 - K1 - Y1 - Z1** (Fig. 8.4). According to the values measured, calculate the clearance between the housing and gudgeon, which is to observe the values in **Tab. 8.2a**.

The **MAX** value of wear allowed is **0.120 mm**



Important

- **Tab. 8.2a** details the dimensional values of new components only.

Tab 8.2a Housing and camshaft gudgeon dimensions.

REF.	DIMENSIONS (mm)	CLEARANCE VALUE (mm)
X	44.000 - 44.025	0.040 - 0.085
X1	43.940 - 43.960	
W	43.000 - 43.025	0.060 - 0.105
W1	42.920 - 42.940	
K	42.000 - 42.025	0.060 - 0.105
K1	41.920 - 41.940	
Y	41.000 - 41.025	0.060 - 0.105
Y1	40.920 - 40.940	
Z	36.000 - 36.025	0.060 - 0.105
Z1	35.920 - 35.940	

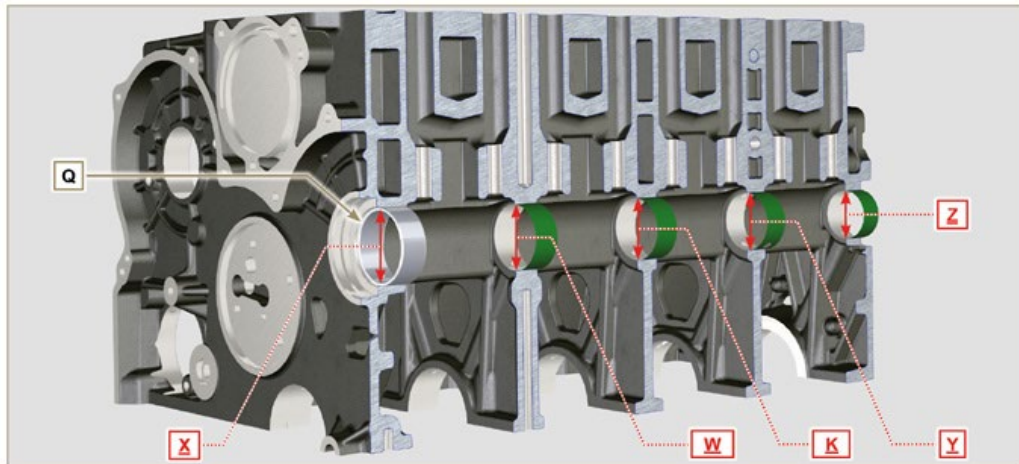


Fig 8.3

8.2.5 Camshaft control for 4 cylinder engine

With a micrometer, measure the maximum dimensions of intake camshaft **R** and exhaust camshaft **S** (Tab. 8.2b).

The **MAX** value of wear allowed is **0.1 mm**.



Important

- **Tab. 8.2b** details the dimensional values of new components only.

Tab 8.2b Camshaft dimensions.

REF.	DIMENSIONS (mm)
R	32.638 - 32.700
S	32.998 - 32.060

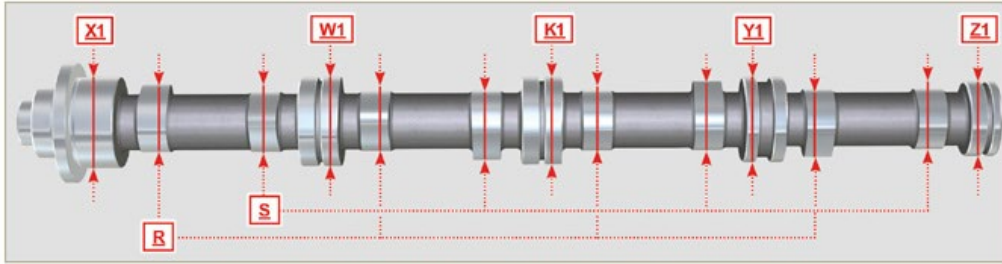


Fig 8.4

8.2.6 3 -cylinder camshaft housing check

The camshaft housings only contain the timing system side bushing **Q**.

Use an internal dial gauge to measure the diameters of housings **X - W - K - Z**.

Use an internal dial gauge to measure the diameters of housings **X1 - W1 - K1 - Z1** (Fig. 8.5). According to the values measured, calculate the clearance between the housing and gudgeon, which is to observe the values in **Tab. 8.2a**.

The **MAX** value of wear allowed is **0.120 mm**



Important

- **Tab. 8.3a** details the dimensional values of new components only.

Tab 8.3a Housing and camshaft gudgeon dimensions.

REF.	DIMENSIONS (mm)	CLEARANCE VALUE (mm)
X	44.000 - 44.025	0.040 - 0.085
X1	43.940 - 43.960	
W	43.000 - 43.025	0.060 - 0.105
W1	42.920 - 42.940	
K	42.000 - 42.025	0.060 - 0.105
K1	41.920 - 41.940	
Z	36.000 - 36.025	0.060 - 0.105
Z1	35.920 - 35.940	

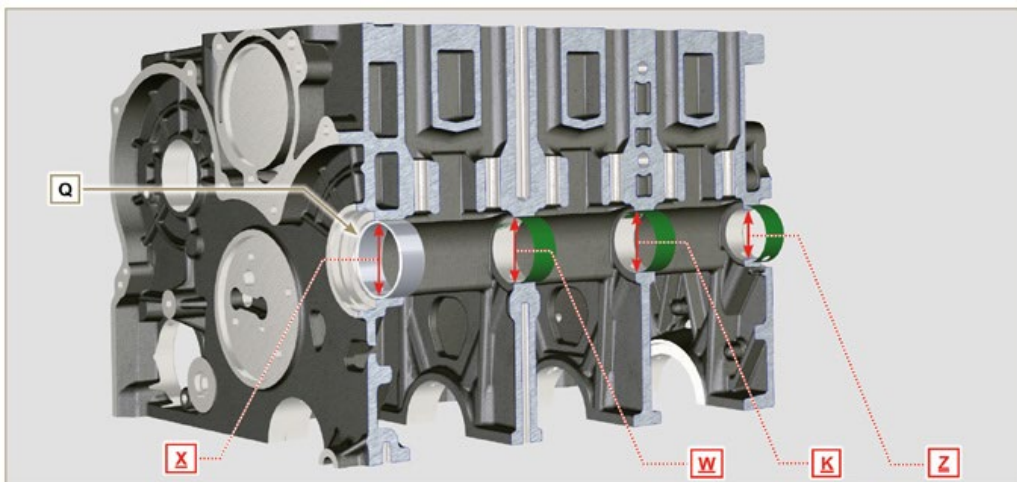


Fig 8.5

8.2.7 Camshaft control for 3 cylinder engine

With a micrometer, measure the maximum dimensions of intake camshaft **R** and exhaust camshaft **S** (Tab. 8.3b).
The **MAX** value of wear allowed is **0.1 mm**.

Tab 8.3b Camshaft dimensions

REF.	DIMENSIONS (mm)
R	32.834 - 32.896
S	33.335 - 33.397



Important

- **Tab. 8.3b** details the dimensional values of new components only.

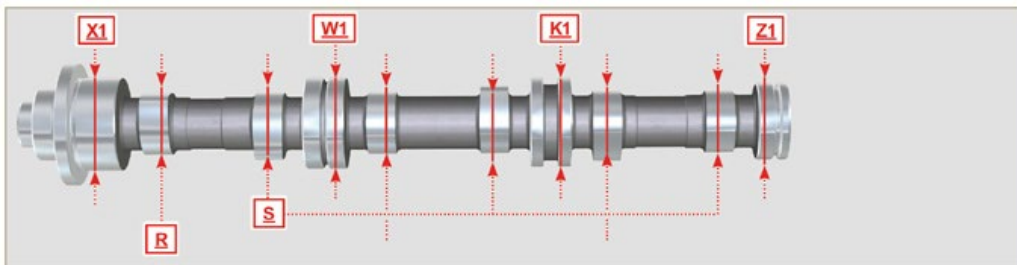


Fig 8.6

8.3 Tappets and tappet housings

8.3.1 Tappets check

Use a surface plate and a dial gauge as shown in **Fig. 8.7**.
Check the perpendicularity of the plate **C**, making the tappet **D** rotate in the direction of the arrow.
The **MAX** value of wear allowed is **0.02 mm**.

With a gauge, check the length of value **A** and **B** (Tab. 8.4).
The **MAX** value of wear allowed is **0.08 mm**.

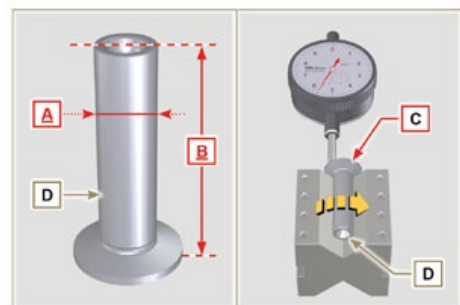


Fig 8.7

8.3.2 Tappet housing check

Use an internal dial gauge to measure the diameter of the tappet housings **X**.
Use value of **A** detected (Par. 8.3.1) to calculate the clearance value (Tab. 8.4).
If the clearance values are not observed, replace the worn component.



Fig 8.8



Important

- Rotate the crankshaft clockwise **ST_34** tool bringing reference **X** upwards.

NOTE: During the positioning phase of reference **X**, check that cylinder N° 1 is in compression phase (intake and exhaust valves of cylinder N° 1 must be in closing position).

Tab. 8.4 *T appet*s and *t appet* housing size.

REF.	DIMENSIONS (mm)	CLEARANCE VALUE (mm)
A	11.966 - 11.984	0.060 - 0.105
X	12.000 - 12.018	
B	46.5 ± 0.2	---

8.4 Crankshaft

8.4.1 Dimensional check and overhauling

Wash the crankshaft thoroughly using suitable detergent.

Insert the pipe cleaner into all lubrication ducts **B** and blow compressed air to free them completely from any dirt residues.

Check the state of wear and integrity of journals **C** and connecting rod **D**.

Perform the operations described in [Par. 9.3.1](#), perform the operations described in [Par. 9.3.6](#) - except Points **2, 4, 9 and 10**.

Measure the crank pins **A1** with a micrometer, and using a dial gauge measure the internal diameter of the connecting rod half-bearings **A2**.

Measure the main journals **B1**, with a micrometer, and using a dial gauge measure the internal diameter of the crankshaft half-bearings **B2**.

If the values described in [Tab. 8.5](#) do not correspond, proceed with grinding all gudgeon pins **A1** and **B1**.

Gear **A** on the crankshaft is timed by a key, assembly of gear **A** on the shaft occurs after heating at a stabilized temperature of +180° C for 5 mins.

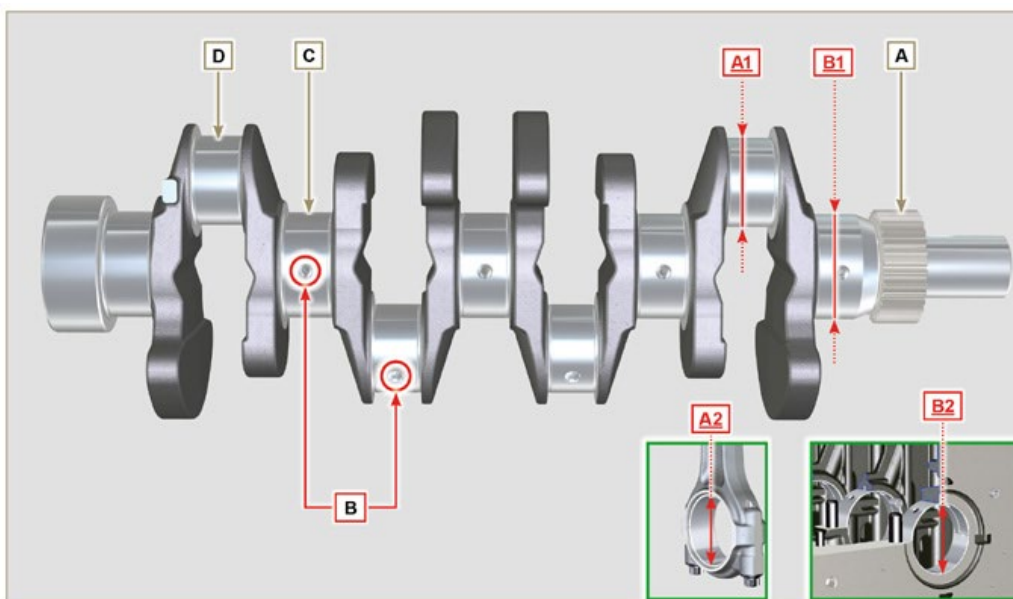


Fig 8.9



Important

- The crankshaft and connecting rod must be replaced every time they are assembled to prevent seizure, as they are made of special lead-free material.
- The **MAX** allowed value of wear for **A1 and A2** is 0.120 mm.
- The **MAX** allowed value of wear for **B1 and B2** is 0.120 mm.
- To grind the crankshaft, a decrease in diameter of the halfbearings and connecting rod is provided for at 0.25 mm and 0.50 mm, to grind gudgeon pins **A1 and B1**, measure the values of diameters **A2 and B2** by assembling the decreased half-bearings, define the diameter to grind of pins **A1 and B1**, observing the clearance indicated in **Tab. 8.5**.
- La **Tab. 8.5** riporta i valori dimensionali solo per i componenti nuovi.

Tab 8.5 Connecting rod and journal diameter

REF.	DIMENSIONS (mm)	CLEARANCE VALUE (mm)
A	53.981 - 54.000	0.035 - 0.085
A1	54.035 - 54.066	
B	63.981 - 64.000	0.035 - 0.102
B1	64.035 - 64.083	

8.4.2 Checking the axial clearance of the crankshaft

Perform the operations described in **Par. 9.3.5 and 9.3.6**.

Using a dial gauge, measure the axial shift of crankshaft **E**. Axial shift must be a **MIN** of 0.18 mm and **MAX** 0.38 mm.. If the values measured do not correspond, replace shoulder rings **D**.

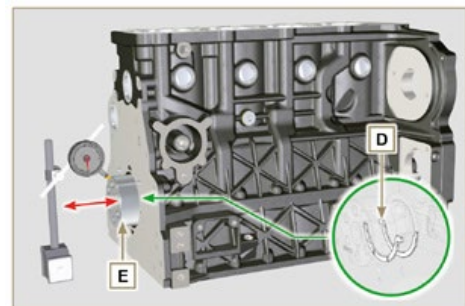


Fig 8.10

8.5 Connecting rod - piston assembly



Important

- **In case of replacement, the connecting rods and pistons must always be replaced for all cylinders.**

8.5.1 Connecting rod dimensions check



Important

- Before assembling the connecting rod and pistons (**Par. 9.3.7 e 9.3.8**), check that the difference in weight between the complete connecting rod and piston units do not exceed 8 gr to prevent weight imbalances during rotation of the crankshaft and consequent damage.
- Mark some references on the connecting rods, caps **Q**, pistons and gudgeon pins to prevent unintentionally confusing the components during assembly. Failure to do this may result in engine malfunctions.
- Connecting rod half-bearings **S** must be there with each assembly.

Check that the contact surfaces are perfectly clean and intact.

Assemble the connecting rod cap **Q** to the connecting rod with the half-bearings **S** and tighten capscrews **P** (tightening torque at **25 Nm**).

With a dial gauge, measure diameters **B** and **D**.

The **MAX** allowed value of wear for **B** and **D** is **0.06 mm**.

Tab 8.6

REF.	DIMENSIONS (mm)	CLEARANCE VALUE (mm)
A	169.980 - 170.020	
B	30.020 - 30.030	0.025 - 0.030
C	29.995 - 30.000	
D	54.035 - 54.066	
E	67.700 - 68.000	
F	29.750 - 29.790	



Important

- **Tab. 8.6** details the dimensional values of new components only.
- Check that the connecting rod and crankshaft half-bearings are coupled properly.
- Refer to the warnings in **Par. 8.4.1** for value **D** decreased.
- If the clearance value between **B** and **C** is not observed, you are required to replace bearing **R** (**Fig. 8.12**).



Fig. 8.11

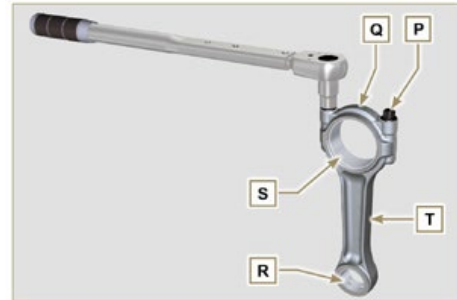


Fig 8.12

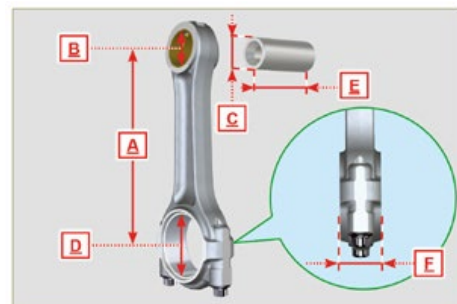


Fig 8.13

Measure value **A**, **C**, **D**, **E** and **F** and confront them with those described in **Tab.8.6**.

If the measured values do not follow those described in **Tab.8.6**, replace connecting rod **T**.

8.5.2 Checking the gudgeon pin-pin axes are parallel

Lubricate gudgeon pin **A** and bearing **R** (**Fig. 8.12**).
Insert the gudgeon pin into bearing **R**. Use a dial gauge to check the axis parallelism of the connecting rod big end and small end.

Parallel deviation (value **V**) measured at the tip of the gudgeonpin, must be a **MIN** of 0,015 and **MAX** of 0,030 mm.

If the parallelism values do not comply with the specified ones, replace the connecting rod with a new one.

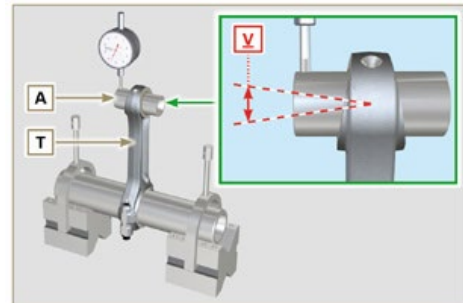


Fig 8.14

8.5.3 Piston rings check

Insert ring **U** into the cylinder, measure value **H** (distance between the points of ring **U**).

Repeat for all the seal rings.

If the measured value **H** does not correspond to the values indicated in the table (**Tab. 8.7**), replace the seal rings **U**.

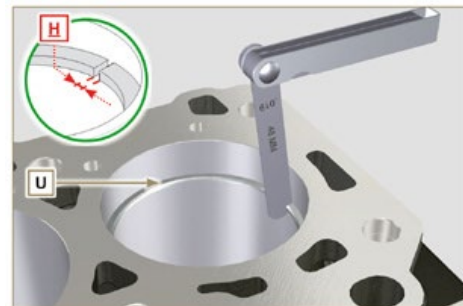


Fig 8.15



Important

- Seal rings cannot be replaced separately.

NOTE: refer to **Fig. 8.19** to locate the rings.

Tab. 8.7

RINGS	H (mm)
U1	0.100 - 0.300
U2	0.250 - 0.500
U3	0.250 - 0.400

8.5.4 Piston dimension check

Clean the piston thoroughly.

Measure the diameter of the piston at 12 mm (quota **L**) from the base of the skirt in correspondence with the graphite lubrication windows **M**.

Refer to **Tab. 8.1b** to establish the clearance value of the pistons with a decreased diameter.

In correspondence with point **W**, there are:

3 digits for the STD piston;

3 digits followed by **R** for a piston with an increased diameter of 0.10 mm;

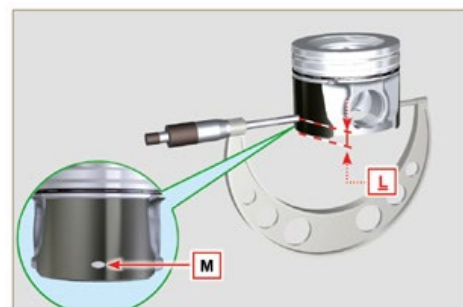


Fig 8.16

+0.5 for a piston with an increased diameter of 0.50 mm;
 +1 for a piston with an increased diameter of 1.00 mm;

If clearance between cylinder and piston is greater than 0,074 mm, the piston and seal rings must be replaced.



Important

- **Tab. 8.1b** details the dimensional values of new components only.

Tab. 8.1b

PISTON	Ø CYLINDERS (± 0.007 mm)	Ø PISTON (± 0.007 mm)	CLEARANCE VALUE (mm)
STD	88.010	87.950	0.046 + 0.074
+0.10	88.110	88.050	
+0.50	88.510	88.450	
+1.00	89.010	88.950	



Important

- With a feeler gauge, measure the clearance of the seal ring in the respective seat (value **L1, L2 e L3**).
- If the clearance does not comply with the values shown in the **Tab. 8.8**, replace the seal rings and the piston.

Tab 8.8

SEAL RINGS	CLEARANCE VALUE (mm)
U1 (L1)	0.110 - 0.150
U2 (L2)	0.070 - 0.115
U3 (L3)	0.030 - 0.065

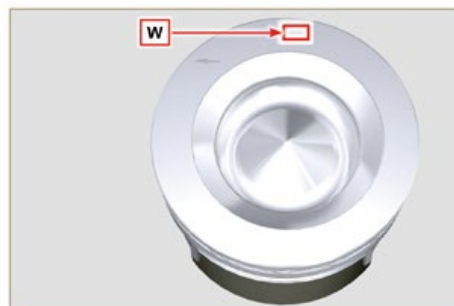


Fig 8.17

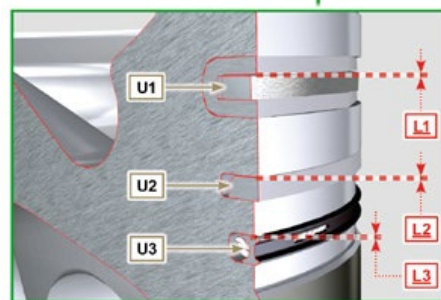
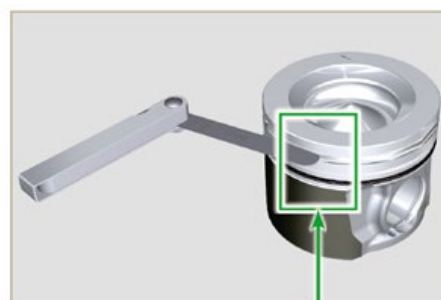


Fig 8.18 and 8.19

8.6 Cylinder head

8.6.1 Flatness check

Put the cylinder head on a surface plate and, with a dial gauge, check the flatness of surface **C**.

The **MAX** value of allowable irregularity of surface **C** is 0.10mm.

If the value is not observed, you are required to grind surface **C**.

The **MAX** removal allowed is 0.20 mm.



Important

- Grinding is to be performed with sleeves **A** of the injectors assembled.

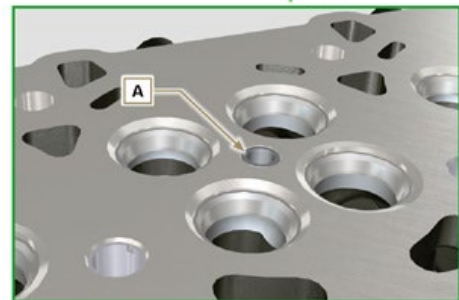
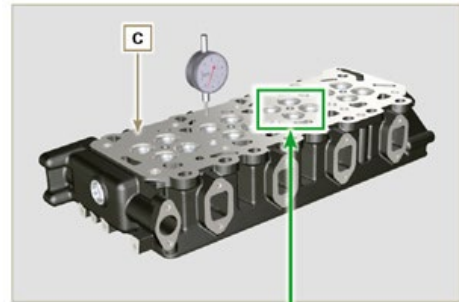


Fig 8.20a - Fig 8.20b

8.6.2 Valve seats check

Thoroughly clean the valves and their seats with.

Measure indentation **B** of each valve with regard to the cylinder head surface **C**, which is to be a **MIN** of 0.60 mm and **MAX** of 0.85 mm.

The **B MAX** indentation allowed on worn components is 1.10 mm.

If the measured value does not correspond with the values indicated, replace the worn component.

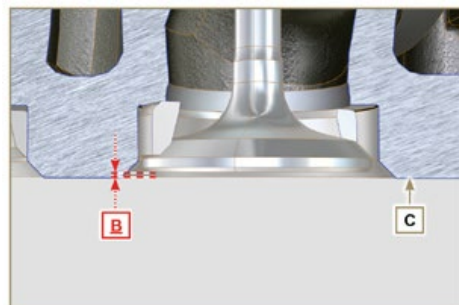


Fig 8.21



Important

- The seats must be worked after driving to reach value **B**, go to a rectification workshop for such operations.

8.6.3 Valve springs

Using a dynamometer, subject the spring to two different forces (in Tab. 8.9) and check that the length of the spring corresponds to the values indicated in the table.

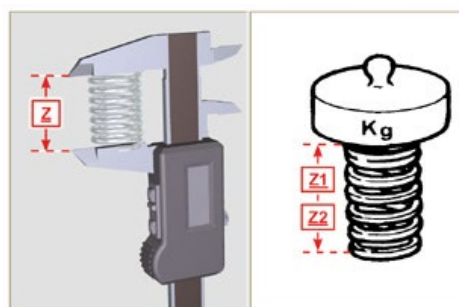


Fig 8.22

^(*) The code **ED0057551850-S** is installed from **S/N 4418801760**

Tab 8.9

WEIGHT (kg)		LENGHT (mm)	
ED0057552810-S	ED0057551850-S ^(*)	Z	
0	0	Z	48.34
13.5	20.4	Z1	30.00
19.5	29.8	Z2	22.00

8.6.4 Valve guides check

Measure the diameters **D** and **E** of the rods and guides valve (Tab. 8.10).

If the diameters don't correspond to the values indicated, replace the valves or guides.

The **MAX** allowed value of wear for **D** and **E** is 0.10 mm.

Observe values **G** from surface **F** when assembling guides **H** (Tab. 8.10).



Important

- Carry out the measurements in different points to detect any ovalisation and/or concentrated wear.
- **Tab. 8.10** details the dimensional values of new components only.

Tab 8.10 Valve stem - valve guide dimensions

REF.	DIMENSIONS (mm)	CLEARANCE VALUE (mm)
D	5.978 - 5.990	0.040 - 0.064
E	6.030 - 6.042	
G	7.000 - 7.020	

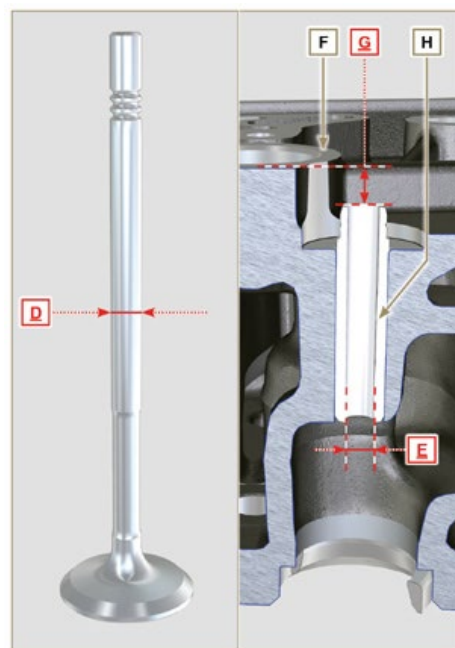


Fig 8.23

8.6.5 Valve guides replacement

The intake and exhaust guides are both made out of grey iron with pearlitic phosphoric matrix and they have the same dimensions.

The guides are press-fit assembled; assembly is possible by cooling the guides with the aid of liquid nitrogen.

Before assembling a new guide, measure value **L** and **M**, calculate the press-fit value, which must observe the values in **Tab. 8.11**.

Observe values **G** from surface **F** when assembling guides **H** (**Tab. 8.10 - Fig. 8.23**).



Important

- The guides must be worked for value **E** (**Tab. 8.10 - Fig.8.23**) after driving. Contact a rectification workshop for such operations.

Tab 8.11 valve guides - housing dimensions

REF.	DIMENSIONS (mm)	PRESS-FIT VALUE (mm)
L	10.000 - 10.015	0.030 - 0.054
M	10.045 - 10.054	

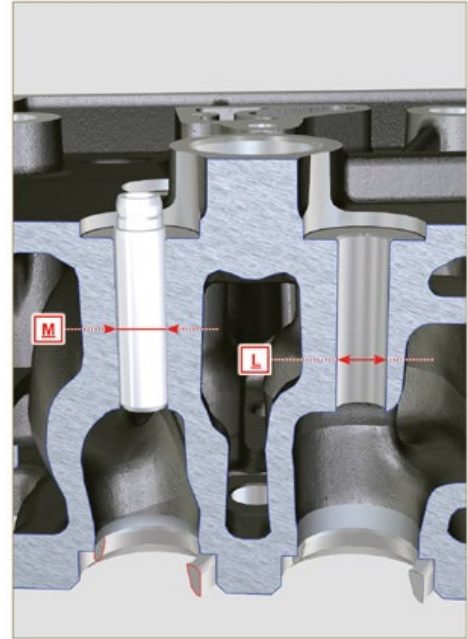


Fig 8.24

8.6.6 Rocker arm check

Measure values **W1** in correspondence with holes **M** located on rocker arm gudgeon **L** (seen from **B** in **Fig. 8.25**).

Measure values **W2** (**Fig. 8.27**).

Based on the values measured, calculate the clearance between **W1** and **W2**, which is to observe the values in **Tab. 8.12**.

Check that all oil pipes **N** and **M** are free from impurities or obstructions.

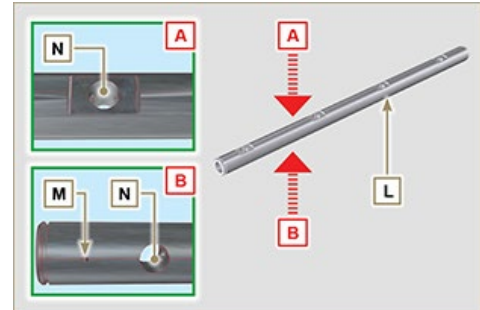


Fig 8.25

Tab 8. 12

REF.	DIMENSIONS (mm)	CLEARANCE VALUE (mm)
W1	19.985 - 20.005	0.035 - 0.076
W2	20.040 - 20.061	

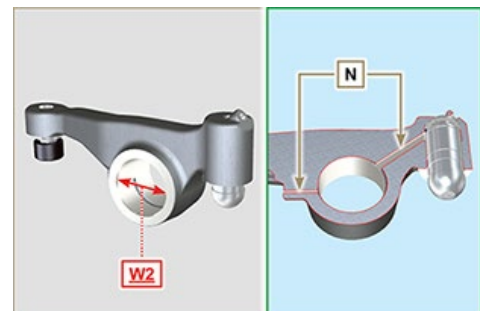


Fig 8.27

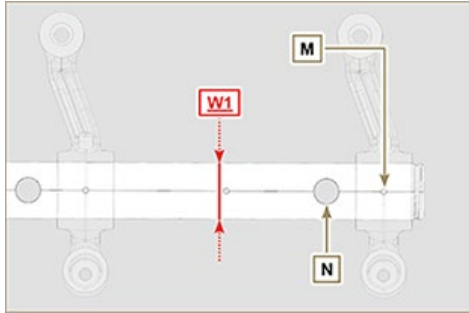


Fig. 8.26

8.7 Oil pump check

8.7.1 Dimensional and visual check

Perform the operations described in [Par.7.8.1](#) and [Par.7.8.4](#).

Measure clearance value **B** between the rotor teeth, the value of allowable wear is **MAX 0.28 mm**.

Clean all the components thoroughly, check that the work surfaces **C** of the rotors and pump body are not worn.



Important

- Should the results from checks carried out not be in accordance with the conditions described, replace the timing system carter together with the oil pump.

On assembly, references **A** must be visible.

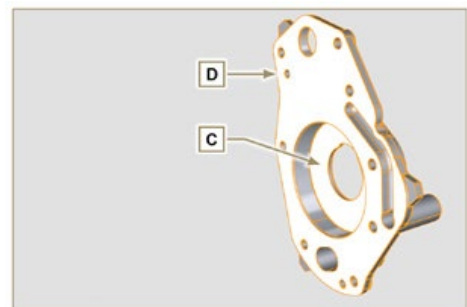


Fig 8.28

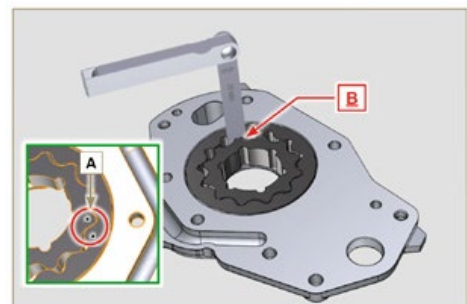


Fig 8.29

8.7.2 Check rotors clearance



Important

Replace carter **R** complete with its oil pump, if there are signs of wear in area **P** of surface **Q** ([Fig. 8.32 - 8.32a](#)).

Measure values **G** and **H** ([Fig. 8.30](#)).

Measure values **L**, **M** and **N** ([Fig. 8.31](#)).

According to the values measured, calculate the clearance between **G** and **H**, **L** and **M** and **L** and **N** which are to observe the values in [Tab. 8.13](#).

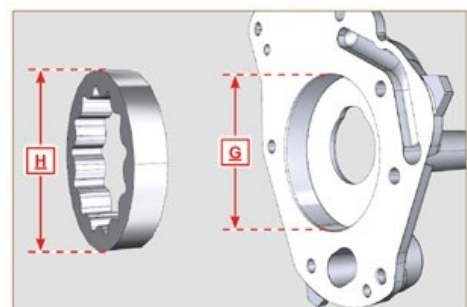


Fig 8.30

For assembly, carry out the operations described from **Par. 9.11.3** to **Par. 9.11.4**.

Tab 8.13

REF.	DIMENSIONS (mm)	CLEARANCE VALUE (mm)
G	82.820 - 82.855	0.032 - 0.075
H	82.500 - 82.540	
L	15.500 - 15.525	0.036 - 0.086
M	15.464 - 15.489	
N		

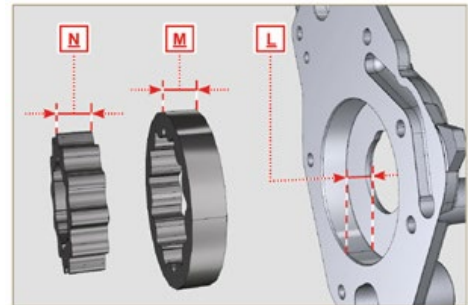


Fig 8.31

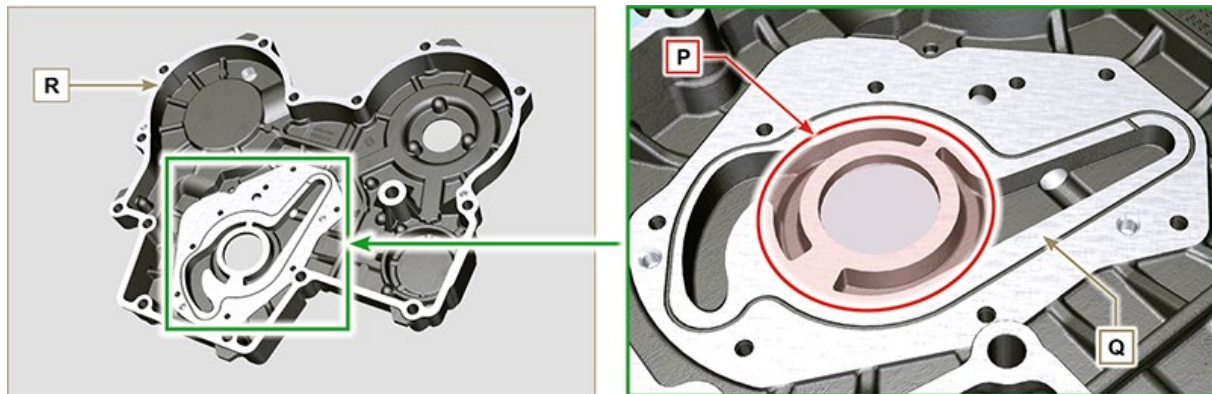


Fig 8.32 - Fig 8.32a

8.7.3 Oil pressure valve check

Measure the free length **F** of spring **D**, which must be **47.91 mm**.

If the measured value does not correspond to the value indicated, replace spring **D**.

Tab 8.14

POS	DESCRIPTION
B	Oil stopper
C	Gasket
D	Spring
E	Piston

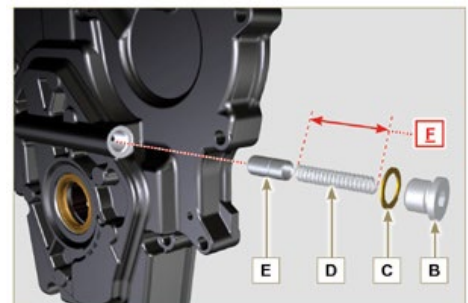


Fig 8.33

9 ASSEMBLY INFORMATION

9.1 Information on engine configuration

- In this chapter, the engine is represented as "**BASE CONFIGURATION**" (refer to [Par 1.3 - Par. 1.4](#)).
- For the assembly of components not described in this chapter refer to [Chap. 11](#).
- The following are the components described in [Chap. 11](#).

11.1 [Oil dipstick in cylinder head](#)

11.2 [Heater \(replacement\)](#)

11.3 [Idler gear \(for 3rd / 4th PTO\)](#)

11.4 [3rd PTO \(replacement\)](#)

11.5 [4th PTO \(replacement\)](#)

11.6 [3rd + 4th PTO \(configurations\)](#)

11.7 [Balancer shafts \(replacement\)](#)

11.8 [Air filter \(cartridge replacement\)](#)

11.9 [Remote oil filter \(disassembly and assembly\)](#)

11.10 [Intake circuit \(replacement\)](#)

11.11 [Muffler \(replacement\)](#)


11.12 [Cooling circuit \(replacement\)](#)

11.13 [Engine feet \(information\)](#)

9.2 Assembly recommendations

- The information is laid out in sequence, the intervention methods have been selected, tested and approved by the manufacturer's technicians.
- This chapter describes the installation procedures for the assemblies and/ or individual components which have already been checked, overhauled or possibly replaced with original spare parts.
- Where necessary, reference to special tools during assembly operations is indicated and identified in [Tab. 13.1](#), hereinafter in [Tab. 9.1](#) an example of a special tool ([ST_05](#)).

Tab. 9.1

SPECIAL TOOLS			
"ST" Code	Picture /draw	DESCRIPTION	PART NUMBER
ST_05		Six nicks Key SN 8	ED0014603650-S



Important

- Before proceeding with operations, read **Par. 3.3.2.**
- To easily locate specific topics, the reader should refer to the **analytical index** or **chapter index.**
- The operator must check that:
 1. the components, the assemblies, the coupling surfaces of the parts are washed, clean and thoroughly dried;
 2. the coupling surfaces are undamaged;
 3. the equipment and tools are ready so that all work can be carried out correctly and safely;
 4. ensure that the working environment is safe.
- The operator must:
 1. carry out the procedures smoothly and safely. It is thus recommended to install the engine on a special rotating stand used when servicing engines to ensure the safety of the operator and the other individuals involved;
 2. tighten the assemblies and / or components in a criss-cross or alternating pattern, initially with a value lower than that preset, and then subsequently, with the tightening torque specified in the procedure;
 3. replace all seal gaskets after each assembly for all components on which they are provided.

9.3 Engine block assembly

9.3.1 Crankshaft bushings



Important

- Execute the procedure in **Par. 8.2.1 and 8.2.2**, before proceeding with assembly..
 - The crankshaft half-bearings are made of special material. Therefore, they must be replaced every time they are assembled to prevent seizures.
1. Fit the new half-bearings **B** onto the crankcase upper half **E** adhering to the reference notches **C**.

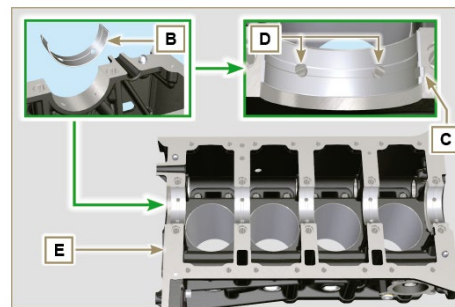


Fig 9.1



Important

- After the half-bearings are fitted, check that the lubrication holes **D** correspond with the crankcase grooves **E**.
 - The lower and upper half bearings **CANNOT** be singularly replaced, and both halves must be replaced together.
2. Fit the new half-bearings **A** onto the lower crankcase **F** using the reference notches **G**.
 3. Lubricate the half-bearings **A and B** with **oil**.

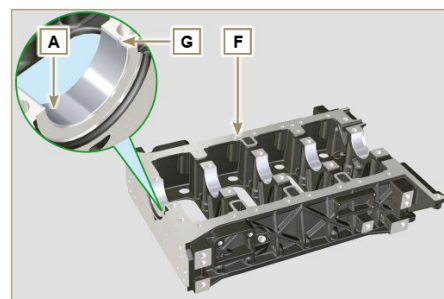


Fig 9.2

9.3.2 Tappets

1. Lubricate the tappets **G** with oil.
2. Insert the tappets **G** into the housings **H** of the upper crankcase.

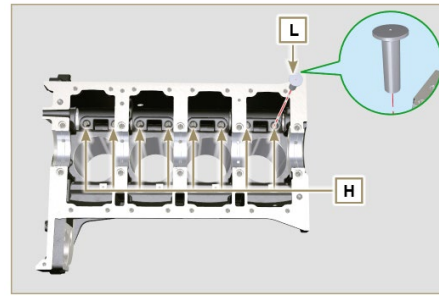


Fig 9.3

9.3.3 Camshaft

1. Check that the bushing **Q** is correctly fitted.
2. Lubricate the pins **L**, the cams **M** of the camshaft **N**, all the housing **P** and the bushing **Q** with oil.
3. Insert the camshaft **N** all the way into its housing **P**.
4. Fit the lock ring **R** on to the crankcase **E** to hold the position of the camshaft **N**.
5. Manually rotate the camshaft **N** ensuring that it is free.

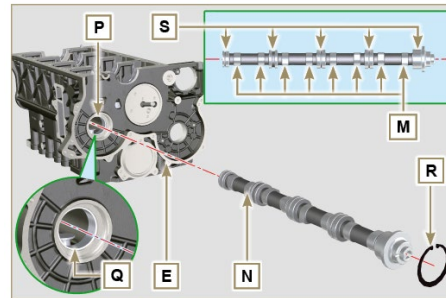


Fig 9.4

9.3.4 Vent compartment closure lid

1. With the screws **CF** tighten the cover **CG** and the gasket **CH** (tightening torque to 10 Nm).

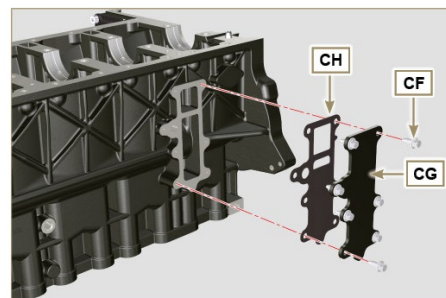


Fig 9.5

9.3.5 Crankshaft



Important

- Carry out the checks described in [Par. 8.4.1](#) and [Par. 8.4.2](#).
1. Check that the crankshaft half-bearings are mounted correctly on the upper crankcase **E**.
 2. Lubricate the main journal and crankpin **J**, with oil.
 3. Insert the crankshaft **W** into its seat on the upper crankcase **E**.

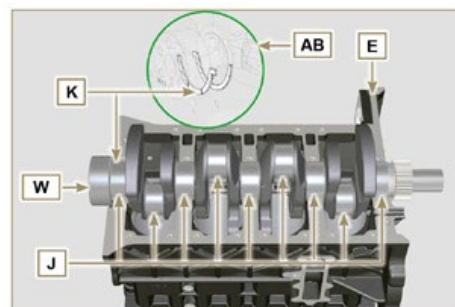


Fig 9.6

4. Insert the 2 shoulder half-rings **K**, between the crankshaft **W** and the upper crankcase **E** (**AB** detail).

9.3.6 Lower crankcase

1. Check that the crankshaft half-bearings are mounted correctly on the lower crankcase **F** (**AC** detail).
2. Assemble the 2 shoulder half-rings **AD** onto the lower crankcase **F** applying two drops of oil to keep them in their seat.
3. Check that the coupling surfaces **AE** are free from dirt and grit.
4. Spread a bead of **Loctite 5660 (rif. AL)** of approx **1 mm** thickness on the surface **AM** of the upper crankshaft half **C** being careful not to block the oil feed grooves **AG** and the return oil sump **AH**.
5. Join the two crankshaft halves **E** and **F** observing the guide pins **AN**.

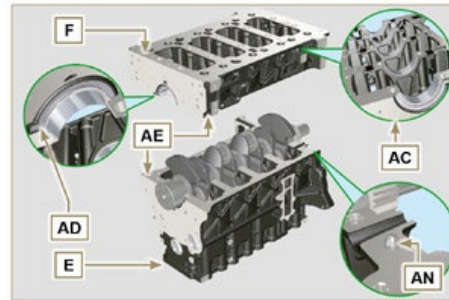


Fig 9.7

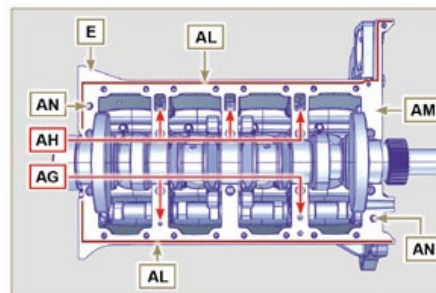


Fig 9.8



Important

- Failure to follow the bolting procedures compromises the functionality of the engine and can cause damage to people and property.
6. Tighten the fastening screws strictly following the sequence and the tightening torque indicated.

Tightening sequence for 3 cylinders

Tightening Screws **Torx M12x1,25** (from the n° 1 to the n° 8):

CYCLE 1 - with a torque of **40 Nm**;

CYCLE 2 - with a torque of **70 Nm**;

CYCLE 3 - with a torque of **120 Nm**.

Tightening Screws **Torx M8** (from the n° 9 to the n° 21):

CYCLE 4 - with a torque of **20Nm**;

CYCLE 5 - with a torque of **35 Nm**;

7. Perform the operations described in **Par. 8.4.2**.

3 Cylinders

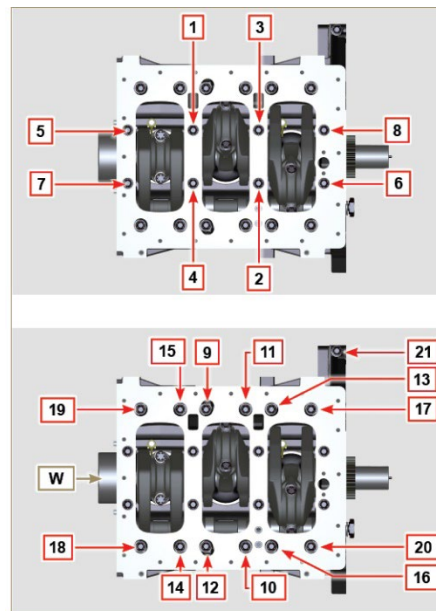


Fig 9.9

8. Check that crankshaft **W** rotates smoothly.

NOTE: In the next illustrations of **Par. 9.3** the coupled crankcase half will be indicated with the letter **E**.

9. Tightening sequence for 3 cylinders

Tightening Screws **Torx M12x1,25** (from the n° 1 to the n° 10):

CYCLE 1 - with a torque of **40 Nm**;

CYCLE 2 - with a torque of **70 Nm**;

CYCLE 3 - with a torque of **120 Nm**.

Tightening Screws **Torx M8** (from the n° 11 to the n° 27):

CYCLE 4 - with a torque of **20Nm**;

CYCLE 5 - with a torque of **35 Nm**;

10. Perform the operations described in **Par. 8.4.2**.

11. Check that crankshaft **W** rotates smoothly.

4 Cylinders

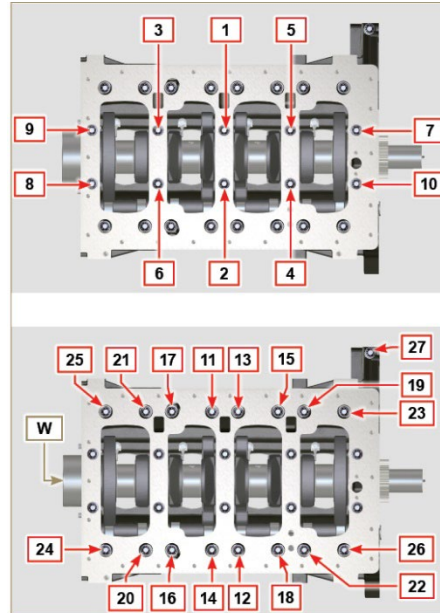


Fig 9.10

9.3.7 Piston rings

1. Perform the operations described in **Par. 8.5.3**.
2. Put the scraper ring **AP** onto the piston **AQ**.
3. Put the 2° seal ring **AR** on the piston **AQ**.
4. Put the 1° seal ring **AS** onto the piston **AQ**.
5. Perform the operations described in **Par. 8.5.4**.
6. Position the segment openings with a 120° angle between them (**Y**).

NOTE: do not use the segment opening with the pin hole (**N**)

7. Lubricate the piston skirt and piston rings with oil.

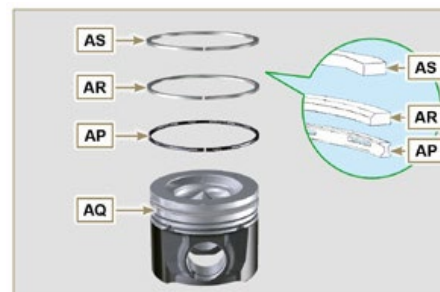


Fig 9.11

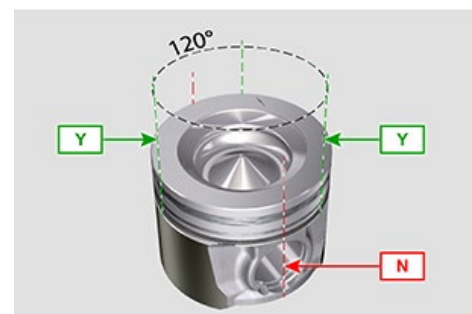


Fig 9.12

9.3.8 Piston and connecting rod



Important

- Before proceeding to the assembly of the piston and connecting rod, carry out the checks described in **Par. 8.5.1**.
- Always replace the bearings **CE** after each assembly.

1. Loosen the screws **AU** and remove the connecting rod cap **AV**.
2. Fit the new bearings **CE**.
3. Insert the connecting rod **AZ** into the piston **AQ** and align the seats **BA**.
4. Insert the gudgeon pin **BB** into the seat **BA** for the assembly of the connecting rod and piston unit.
5. Insert the lock rings **BD** inside the seat **BE** of the piston **AQ** to lock the gudgeon pin **BB**.

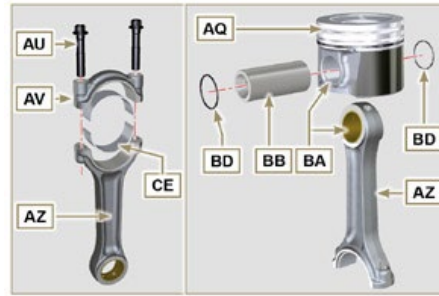


Fig 9.13

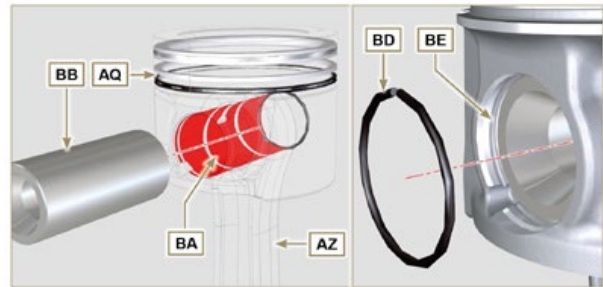


Fig 9.14 - Fig 9.15

9.3.9 Piston and connecting rod assembly



Important

- Before assembling the piston and connecting rod assemblies, execute the controls described in **Par. 8.5**

1. Rotate the crankshaft **W** by moving the crankpin **BG** to a TDC position of the affected cylinder.
2. Push the piston **AQ** downwards by centering the crankpin **BG** with the connecting rod **AZ**.
3. Turn the crankshaft on support to assemble the con rod capp on cylinder 1 and 4.

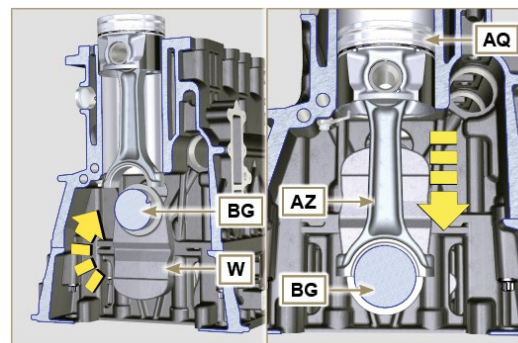


Fig 9.16

4. Check that the half-bearing **AS** is mounted correctly on the connecting rod cap **AV**.


Important

- As the rods are divided by breaking pay particular attention to the coupling of the cap on the connecting rod.
 - Check before you screw and tighten the bolts that the breaking surfaces are perfectly flush.
5. Couple the connecting rod cap **AV** to the connecting rod **AZ** using the marks made at disassembly (**Par. 7.13.2**)
 6. Screw in the screws **AU**.
 7. Repeat the operations from 1 to 6 for the cylinders 2 and 3.


Important

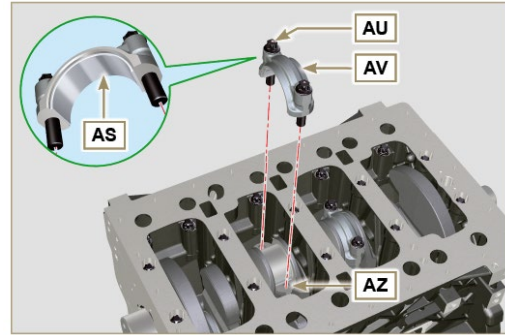
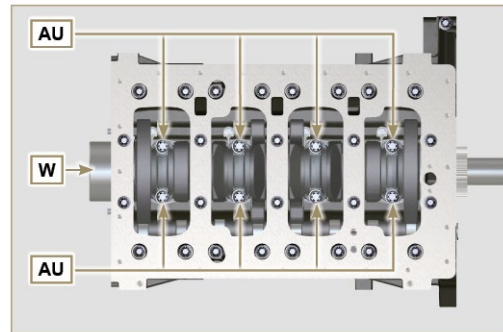
- Failure to follow the assembly procedures compromises the functionality of the engine and can cause damage to people and property.
8. Tighten the screws **AU**, alternately, strictly following the tightening torques indicated.

Tightening sequence of screws **Torx M10x1**:

- 1° **PHASE** - with a torque of **40 Nm**;
- 2° **PHASE** - with a torque of **85 Nm**;

9. Check that the connecting rods have axial play and the crankshaft **W** rotates smoothly.

NOTE: After the check carried out at point 8, position the shaft **W** with the first cylinder to TDC.


Fig 9.17

Fig 9.18

9.3.10 Crankshaft gasket flange



Important

- Check that the contact surface between the flange and the crankcase is free of grit and dirt.
 - Always replace the gasket **BS** after each assembly.
1. Check that there are bushings **BT** on the crankcase **E**.
 2. Lubricate the oil seal lip **BU**.
 3. Position the gasket **BS** and flange **BV** on the crankcase **E** in correspondence with the bushings **BT**.
 4. Put **Loctite 243** on the **2** screws **BW** matching the bushings **BT**.
 5. Screw the fastening screws all the way in **BW** without tightening them.
 6. Tighten all the screws **BW** strictly following the tightening sequence indicated (tightening torque to **10 Nm**).

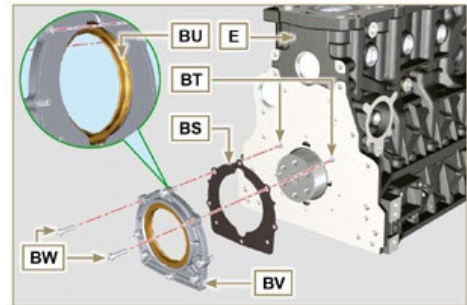


Fig 9.19

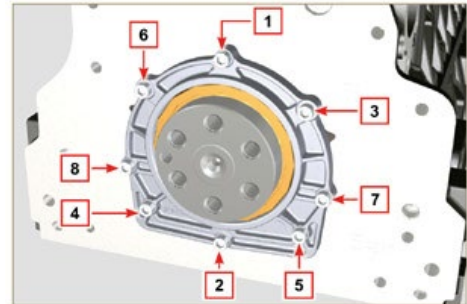


Fig 9.20

9.3.11 Cover 3rd PTO



Important

- Replace capscrews **CA** with each assembly or alternatively apply **Loctite 2701** on the thread.
1. Secure the cover **CB** with the screws **CA** and **CC** inserting the gasket **CD** (tightening torque **25 Nm**).



Fig 9.21

9.4 Oil sump unit assembly

9.4.1 Oil fume pipes

1. Apply **Loctite 648** on the pipe threads **A**.
2. Screw and tighten the pipes **A** (tightening torque of **15 Nm**).

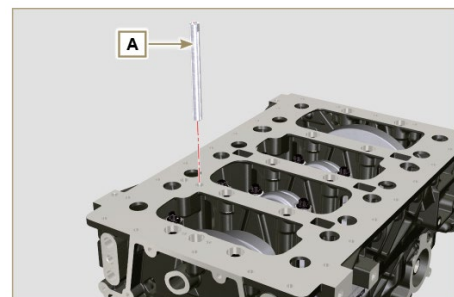


Fig 9.23

9.4.2 Oil suction pipe



Important

- It is mandatory to replace the gasket **B** after each assembly.
- Always replace capscrews **D** with new ones or alternatively apply **Loctite 2701**.

1. Insert the new gasket **B** in the seat of the oil suction hose flange.
2. Secure the hose **C** on the crankcase **E** with the screws **D** (tightening torque **10 Nm**).

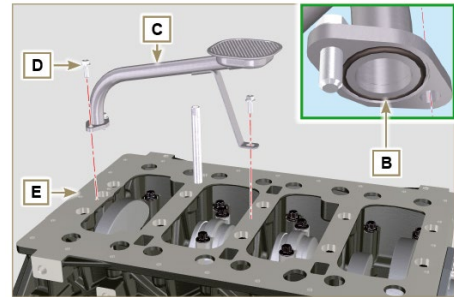


Fig 9.24

9.4.3 Oil Sump

1. Ensure that the contact surfaces **F** of the oil sump **G** and the crankcase **E** are completely clean.
2. Apply a bead of approx. **2.5 mm** of sealant (**Loctite 5660**) on the surface **F** of the oil sump **G**.
3. Rotate the crankshaft clockwise **ST_34** tool bringing reference **X** upwards.

NOTE: During the positioning phase of reference **X**, check that cylinder N° 1 is in compression phase (intake and exhaust valves of cylinder N° 1 must be in closing position).

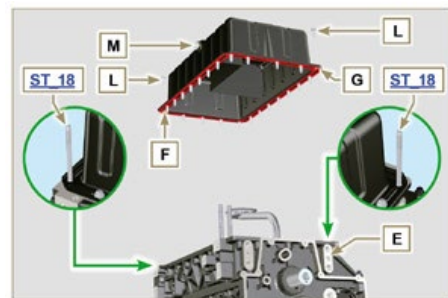


Fig 9.25



Important

- Tighten the screws **L**, strictly following the sequence and tightening torque indicated.
4. Tighten the screws **L** following the sequence indicated (tightening torque **25 Nm**).
 5. Remove the two studs **ST_18** with the appropriate screws (tightening torque 25 Nm)
 6. After tightening all of the screws, loosen screw **n°1** and retighten it to the torque value specified in step **4**.
 7. Check that the oil drain plugs **M** are tight (tightening torque **35 Nm**).

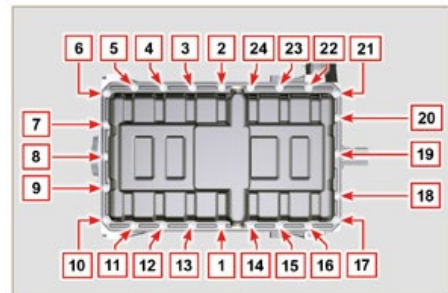


Fig 9.26

9.5 Flange unit assembly

9.5.1 Bell housing



Danger

- Bell **A** is very heavy; pay special attention during assembly operations to avoid dropping and causing serious risks to the operator.

1. Install the bell housing **A** in accordance with the reference pins **B** on the base **C**.



Important

- Failure to adhere to the assembly procedures may compromise the functionality of the engine, and also cause damage to persons and property.
2. Tighten the fastening screws **D** strictly following the tightening sequence indicated (tightening torque **50 Nm**).

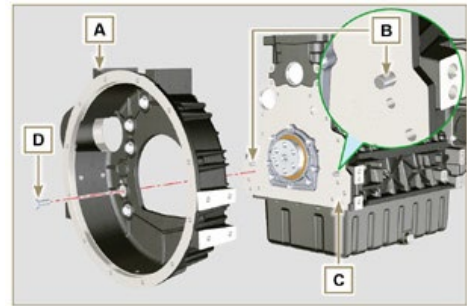


Fig 9.27

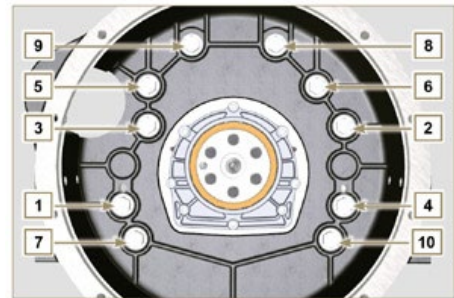


Fig 9.28

9.5.2 Flywheel



Danger

- Flywheel **F** is very heavy; pay special attention during assembly operations to avoid dropping and causing serious risks to the operator.

1. Screw the special tool **ST_09** on the crankshaft **E** instead of the screws **G** positioned higherup (Fig. 9.29).
2. Insert the flywheel **F** on the crankshaft **E** using the tool as a guide **ST_09** and manually tighten all the screws **G** (the last screw is fitted in the place of the tool **ST_09**).
3. Mount the tool **ST_34** in the seat of the starter motor **H** and fit it with the two starter motor fixing screws.
4. Tighten the screws **G** (tightening torque at **140 Nm**).

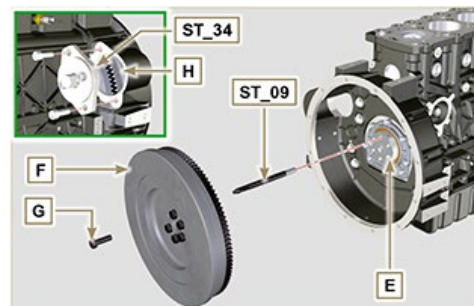


Fig 9.29

9.6 Timing system gear assembly and injection pump

9.6.1 Timing system gear assembly

1. Check that the key **A** is correctly fitted on the camshaft **B**.
2. Position the gear **C** on the camshaft **B** adhering to the key reference **A**.
3. Screw capscrew **D** until the end.
4. Tighten the middle gear pin **H**, in the housing **J** of the crankcase, with the screws **K** (tightening torque **25 Nm**).

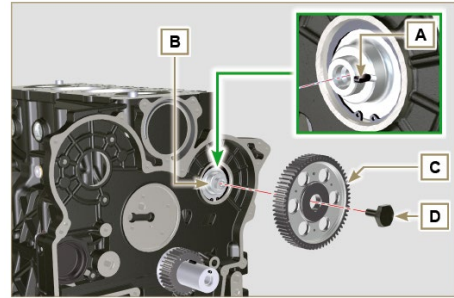


Fig 9.30



Important

- The fitting of the middle gear pin **H** has only one position, the 4 screw holes **K** are asymmetric.
 - Always replace the gasket **L** at each assembly.
5. Insert the shoulder ring **M**.
 6. Check the integrity of the bushing **N** into the middle gear **P**, and ensure that it is free from impurities.
 7. Thoroughly lubricate the pin **H** and the bushing **N**.
 8. Position the gear **P** on the pin **H** observing all the marks **W** of the gears **C** and **S** (Fig. 9.33).

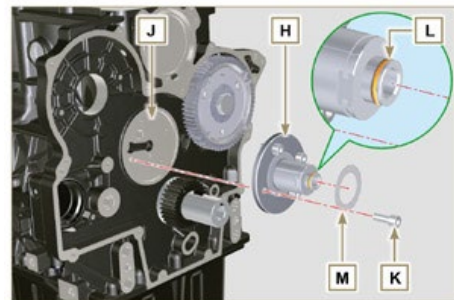


Fig 9.31



Important

- Failure to comply with the marks **W** on the gears **C**, **P** and **S**, causes engine malfunction and serious damage.

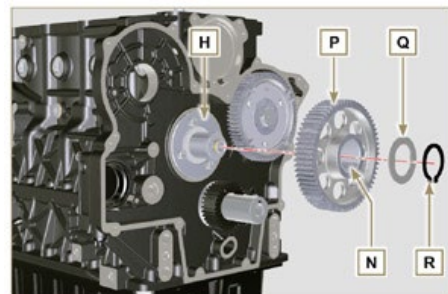


Fig 9.32

9. Insert the shoulder ring **Q** and the lock ring **R**.
10. Tighten the screw **D** (Fig. 9.30 - tightening torque at **100 Nm**).

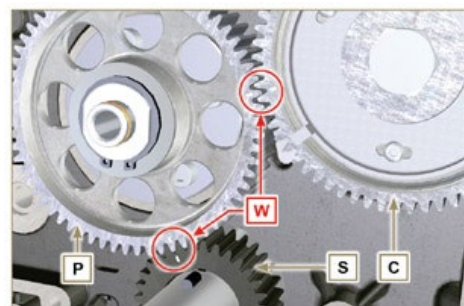


Fig 9.33

9.6.2 Injection pump



Important

- Always change screws **T** with new ones or alternatively apply **Loctite 270 (Fig. 9.34)** to the threads.
1. Perform the operations described in the warning in **Par. 6.1.5.**
 2. Place a dial gauge to detect the TDC on piston N° 1, then bring the indicator of the dial gauge to **0**.

NOTE: During the detection phase of the TDC, check that cylinder N° 1 is in compression phase (align the notches **W** as in **Fig. 9.33**).

3. By means of the identified pump code, refer to **Tab. 6.1** to know the advance degrees and the corresponding value to lower the piston.
4. Mount tool **ST_34** in the seat of starter motor **H** (**Fig. 9.29**) and fix it with two motor fixing screws.
5. Having identified the value to lower the piston, rotate the crankshaft anti-clockwise by going beyond the value described in **Tab. 6.1**, once again, rotate the crankshaft clockwise stopping at the correct advance value by using tool **ST_03 - ST_34**.
6. Lock the **ST_34**, ensure that the crankshaft does not rotate, which would alter the correct advance value.
If this happens, repeat the instructions described in points **4, 5 and 6**.

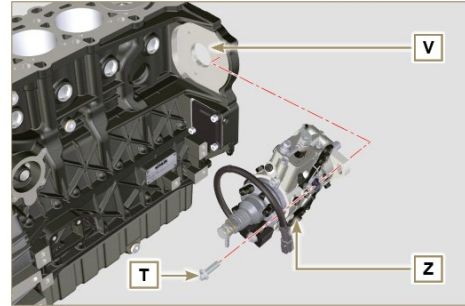


Fig 9.34

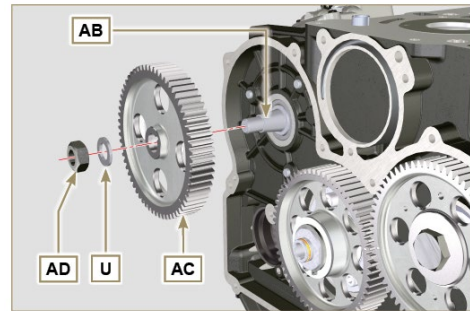


Fig 9.35

7. Fix pump **Z** into housing **V** by means of screws **T** (Fig. 9.34 - tightening torque at **25 Nm**).
8. Position the gear **AC** onto shaft **AB** of the pump.

NOTE: You are not required to respect the reference **Q** gear **AE** (Fig. 9.36).

9. Insert washer **U** and tighten nut **AD** (tightening torque at **70 Nm**).



Important

- In the event of assembling screw **X1** (tightening torque at **10 Nm**).
- In the event of assembling screws **X2** and **X3** (tightening torque at **2.5 Nm**).

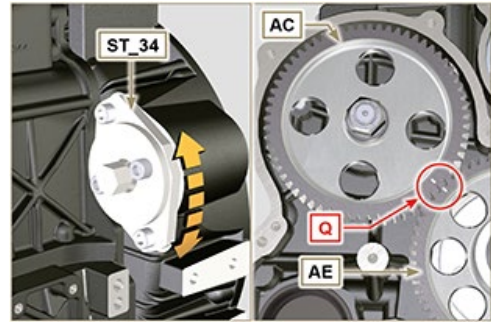


Fig 9.36

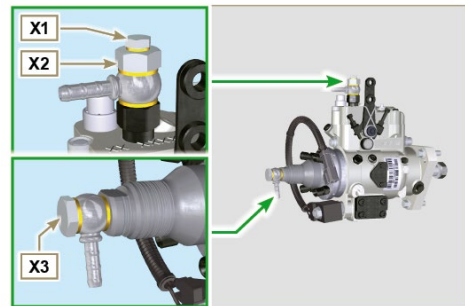


Fig 9.37

9.7 Cylinder head unit assembly

9.7.1 Valve stem gasket



Important

- Carry out the checks described in **Par. 8.6.4** before proceeding with the following operations.
 - Always replace gasket **A** with every assembly
 - Lubricate the gaskets **A** on the inside.
1. Fit the oil seals **A** on the valve guides **B** using the tool **ST_08**.

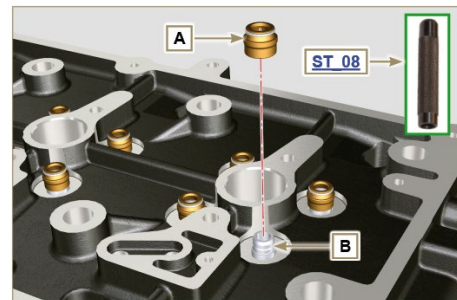


Fig 9.38

9.7.2 Injector sleeves (↔)

1. Insert the seals **C** in the seats of the sleeve **D**.
2. Insert the seal **E** with the convex side facing upward at the base of the sleeve **D**.
3. Lubricate the gaskets **C**.
4. Insert and carefully screw the sleeve **D** into the seat of the head **F**.

NOTE: The sleeve **D** must not protrude above the surface of the head **BF**.

5. Clamp the sleeve **D** (tightening torque at **30 Nm**).

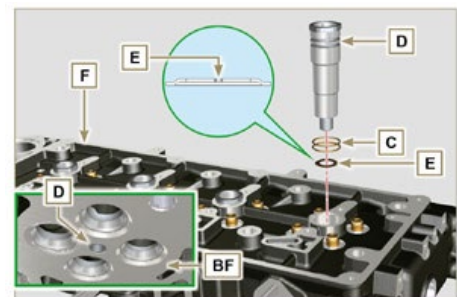


Fig 9.39

9.7.3 Injectors projection

1. Insert the injector **G** inside the sleeve **H**.
2. Mount the injector fixing bracket **M** and secure it with the screw **N**, without performing the calibration.
3. Check protrusion of injectors by means of the tool **ST_03** (Fig. 9.44), check the projection of the injector, which must range between $1.68 \div 2.42$ mm.

NOTE: if the value detected does not correspond, replace gasket **Q** with a different thickness.

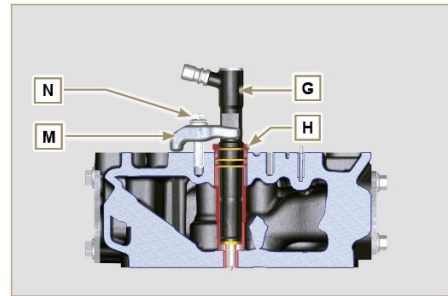


Fig 9.40

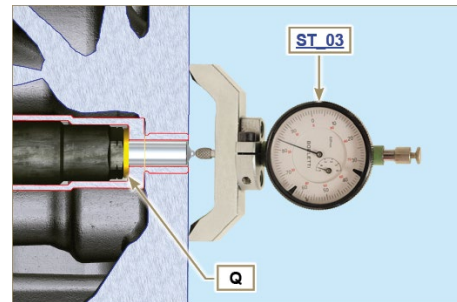


Fig 9.41

9.7.4 Valves

1. Pre-lubricate and insert the valves **X** into the head **F** taking care to fit them in the original positions as per the reference marks made in **Par. 7.13.4.1**.
2. Position the spring **Y** on the seat of the head **F**.
3. Position the disk **S** on the spring **Y** centering the valve **X**.
4. Mount the tool **ST_07** on the head **F** fixing it on one of the holes for securing the rocker arm cover.

NOTE: Change the fixing hole according to the position of the valves to be fitted.

5. Position the tool **ST_07** on the valve as shown in the figure.

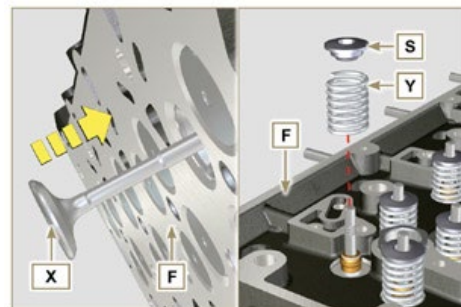


Fig 9.42

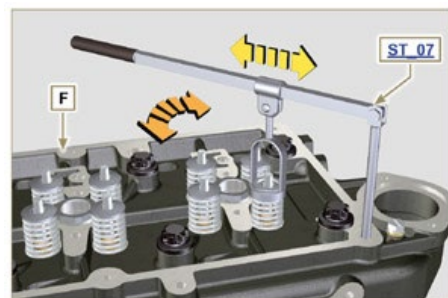


Fig 9.43

6. Push the lever of the tool **ST_07** downwards, in order to lower the valve disks **S** in the direction of the arrow **AK**, and insert the valve cutters **AJ** inside the disk **S**.
7. Check that the valve cutters **AJ** are properly mounted on the valve seats **X** and release the tool **ST_07**.

NOTE: repeat all the steps for the relevant valves and remove the tool **ST_07**.

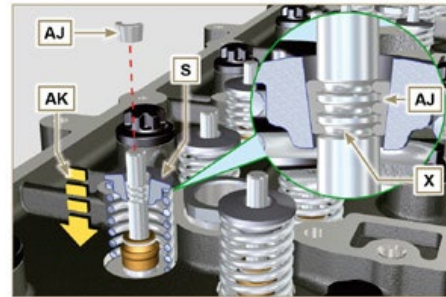


Fig 9.44

9.7.5 Cylinder head

1. Fix the eyebolts **AW** with the screws **AX** onto the head **F** (tightening torque of **25 Nm**).
2. Position the piston **P** at the TDC.
3. Position the tool **ST_03** on the crankcase surface of the head and measure the piston protrusion **P** from head level **K** in 4 diametrically opposed points **R**. Repeat the operation for all pistons **P** and take note of the highest average value, determining value **S** (Tab. 9.2).

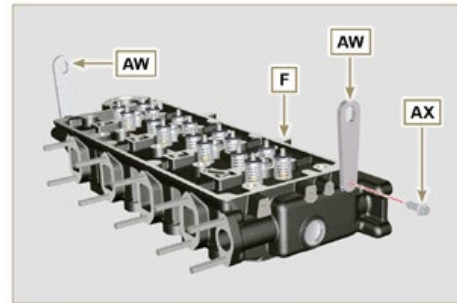


Fig 9.45

Tab. 9.2

S (mm)	Hole number
0.030 - 0.126	1 
0.127 - 0.250	2 
0.251 - 0.375	3 

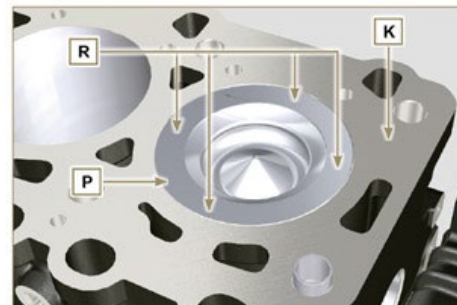


Fig 9.46

4. Based on the value detected at point **3**, select the relevant gasket **T** as shown in the **Tab. 9.2** (**Fig. 9.47** detail **U**).
5. Check that the crankcase surface **K** and the gasket **T** are completely free of dirt and grit.



Important

- The head gasket must be replaced for each assembly.
6. Position the gasket **T** on the surface **K** with reference to the centering bushings **J**.

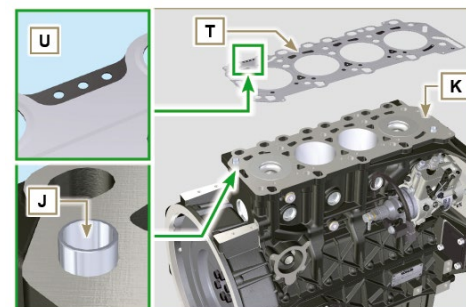


Fig 9.47

7. Check that the surface head **W** is free from impurities.
8. Position the head **F** on the crankcase **Z** with reference to the centering bushings **J**.



Important

- The fastening bolts **V** must be replaced every time they are assembled.
9. Secure the head **F** by tightening the screws **V** strictly following the sequence indicated in the **Fig. 9.52** or **Fig. 9.53** and the tightening torque indicated in the **Tab. 9.3**.



Important

- Failure to adhere to the bolt fixing procedures may compromise the functionality of the engine, and also may cause damage to persons and property.
- Tighten capscrews **V** observing the cycles, tightening, and subsequent rotation as indicated in **Tab. 9.3**.
- For engine **KDI 1903 M**: 8 screws **Torx M12x1,25** (**Fig. 9.49**).
- For engine **KDI 2504 M**: 10 screws **Torx M12x1,25** (**Fig. 9.50**).

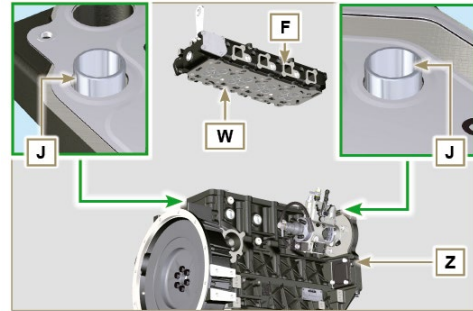


Fig 9.48

3 CYLINDERS

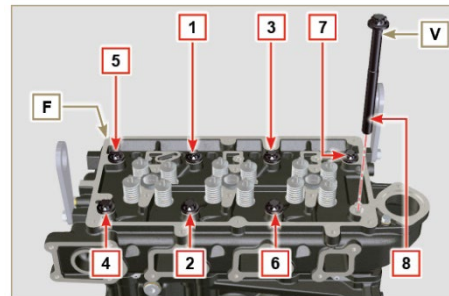


Fig 9.49

4 CYLINDERS

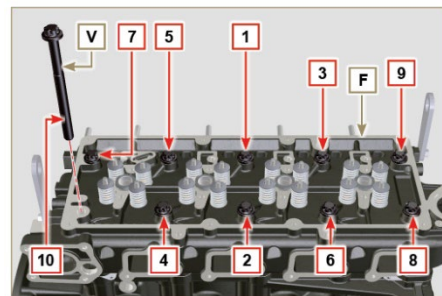


Fig 9.50

Tab. 9.3

CYCLE	TORQUE
1	40 Nm
2	70 Nm
3	100 Nm
4	90°
5	90°
6	90°

9.7.6 Rods and valve bridges

1. Insert the rocker control rods **AA** into the niches of the head **F**.



Important

- Properly centre the rods **AA** into the spherical housing of the camshaft tappets **AB**.
2. Mount the valve bridge **AC** on to the pairs of discharge and suction valves.

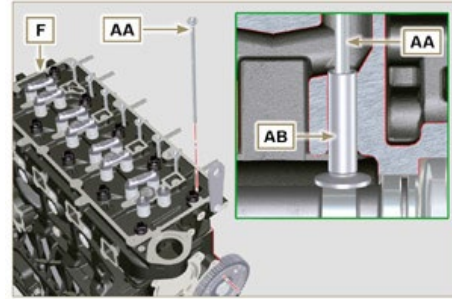


Fig 9.51

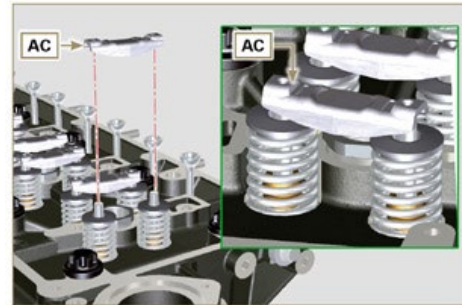


Fig 9.52

9.7.7 Rocker arms



Important

- To correctly position the rocker arms, turn the rocker arm pin **AH** with the lower height **AL** towards the timing system side as in **Fig.9.54**.
 - The discharge rocker arm **AT** is shorter than the suction arm **AR**.
1. Fit the lock ring **AM** into the seat **AN** of the rocker arm pin **AH**.
 2. Position the pin **AH** with the screw support surface **AP** facing upwards and insert the 2 shoulder rings **AQ**.
 3. Insert in sequence the suction rocker arm **AR**, the holder **AS** and the discharge rocker arm **AT** in the pin **AH**.
 4. Insert the spring **AU** in the pin **AH**.
 5. Repeat points **3, 4** for all the rocker arms.
NOTE: The holder **AV** must be fitted with the last pair of rocker arms towards the flywheel.
 6. Insert 2 shoulder rings **AQ** and the lock ring **AN** to lock all the components inserted in the pin **AH**.
NOTE: The spring **AU** ensures that the supports **AS** and **AV** are kept in place.

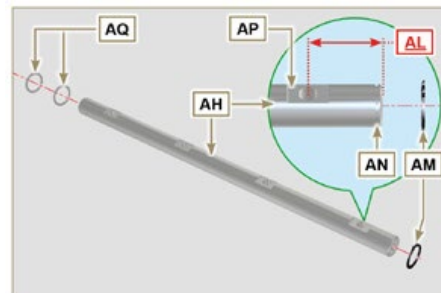


Fig 9.54

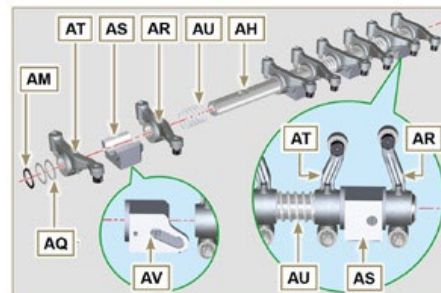


Fig 9.55

9.7.8 Rocker arm pin assembly



Important

- Position the rocker arm pin assembly **BB** on a level to align all the support surfaces.
 - Check that the pistons are positioned half way between the TDC and BDC. Rotate the crankshaft 90° counterclockwise with regard to the 1st cylinder TDC, positioning the crankshaft pin **BP** as shown in Fig 9.58a. If the crankshaft pulley and the timing gear cover have not been removed, rotate the crankshaft positioning the reference **BQ** located on the target wheel in correspondence of the speed sensor, as shown in Fig. 9.58b.
1. Position the rocker arm pin assembly **BB** on the head **F**, respecting the plug **BC** on the head using the holder indicated **AV**.
 2. Check the correct positioning of all the rocker arms and the u-bolt control valves (detail **BD**). House the tappet in the seat of the rocker arms control rod.
 3. Secure the rocker arm pin **BB** tightening the screws **BE** (tightening torque to **25 Nm**). Adhere to the screw tightening sequence **BE** as shown in Fig. 9.60.

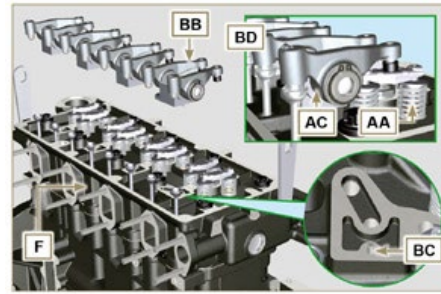


Fig 9.56

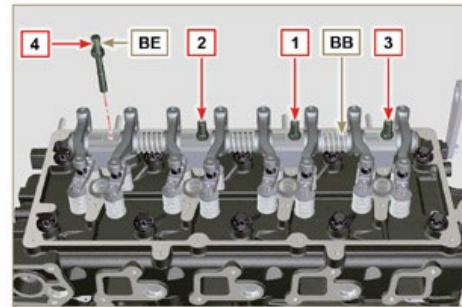


Fig 9.57

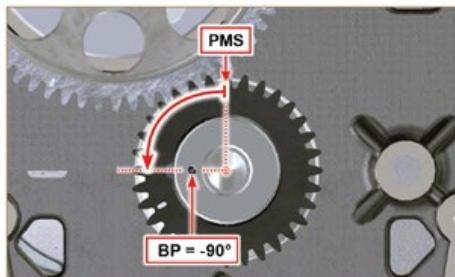


Fig 9.58a

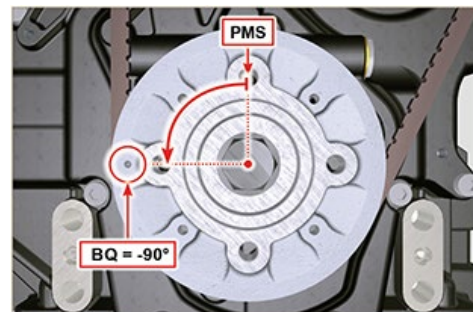


Fig 9.58b

9.8 Fuel system assembly



Important

- Replace the high pressure pipes after two disassemblies.
- Remove the protective caps from all the components of the fuel circuit just before assembly (**Par. 2.9.7**).
- When repaired, **RSN-A** injectors must be certified by a Stanadyne centre to check their correct operation - check the type of engine mounted injectors on the spare parts list (**RSN-A** is specified in the description).

9.8.1 Injector

1. Lubricate the gaskets **U**, **T**, **S**, and fit them on the injector **Z**.



Fig 9.59

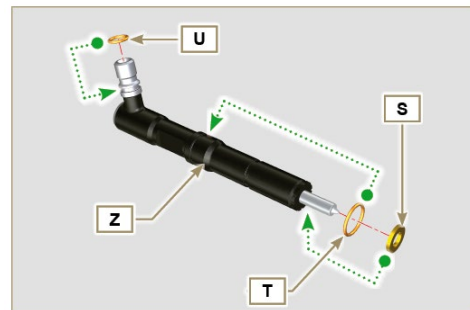


Fig 9.60

2. Fit the injector **Z** in the sleeve **V**.

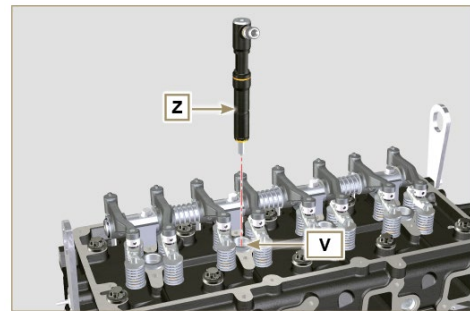


Fig 9.61

3. Assemble parts **P**, **Q**, **R**.
4. Fit the parts so assembled on the injector **Z**.

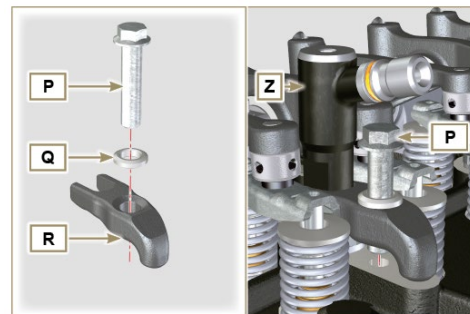


Fig 9.62

5. Insert tool **ST_51** on the injectors junctions **Z** (detail **X1**).
6. Tighten the screw **P** (tightening torque to **20 Nm**).

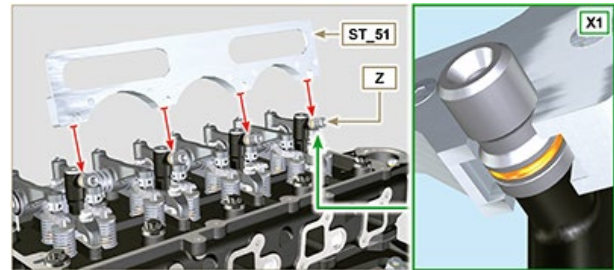


Fig 9.63

9.8.2 Fuel injector ricicle pipe

1. Position the tube **N** on the injectors **Z**, and tighten screws **M** (coppia di serraggio a **14 Nm**) and insert the gasket **T**.

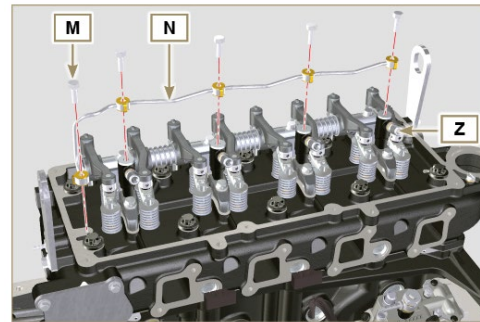


Fig 9.64

9.8.3 Rocker arm cover



Important

- Always replace the gaskets **AK** after each disassembly (**ST_36** - apply Loctite 480 to the seats of cap **C** before assembling the gaskets)..

1. Position tool **ST_17** onto the head in correspondence with the two fastening holes **5** and **6** (Fig. 9.66 - 9.67).
2. Position the gasket **AM** on the head **AL** using tool **ST_17** as a guide.
3. Fit the rocker arm cap **C** on the head **AL** via the screws **L** observing the clamping sequence illustrated in Fig. 9.66 (KDI 1903 M) or Fig. 9.67 (KDI 2504 M) (tightening torque at **10 Nm**).
4. With vaseline lubricate the gaskets **AK**.

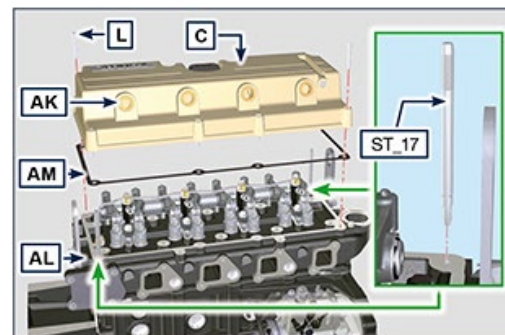


Fig 9.65

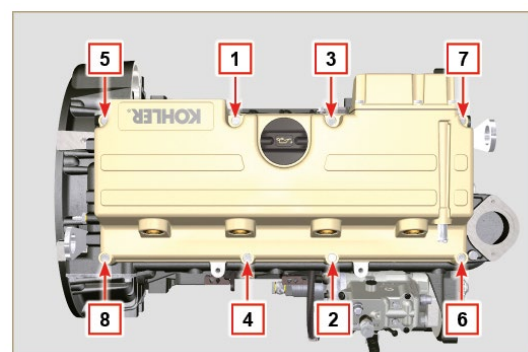


Fig. 9.67

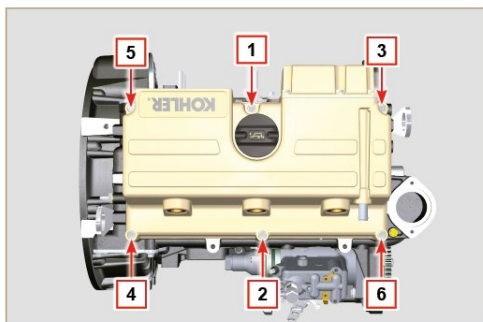


Fig 9.66

9.8.4 Installation of the fuel injector pipes (injection pump/injectors)



Important

- Replace the high pressure pipes after two disassemblies.
1. Position pipes **D** on the injectors and on the injector pump and tighten the nuts **E** and **F** manually, without clamping them.
 2. Clamp the nuts **E** and **F** (tightening torque at **25 Nm**).
 3. Mount the retainers **C** of the hoses **D**.

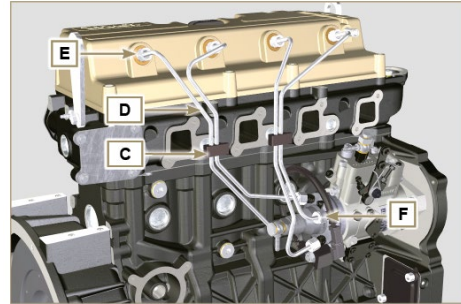


Fig 9.68

9.8.5 Fuel filter

1. Secure the fuel filter holder **J** with the screws **K** on the crankcase **W** (tightening torque of **25 Nm**).

NOTE: For the assembly of the fuel cartridge, refer to operation 2 of **Par. 6.7.2**.

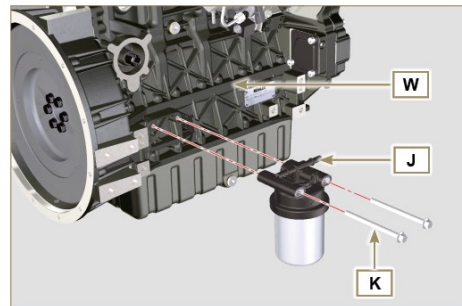


Fig 9.69

9.9 Intake manifold assembly



Important

- Check that the contact surfaces between the collector **C** and the head **D** are free from impurities.
1. Insert **ST_18** special tool into market point.
 2. Mount the gasket **A** on the head **D**.
 3. Mount the manifold **C** on the head **D**.
 4. Fit the manifold **C** using the screws **B** (tightening torque of **25 Nm**).

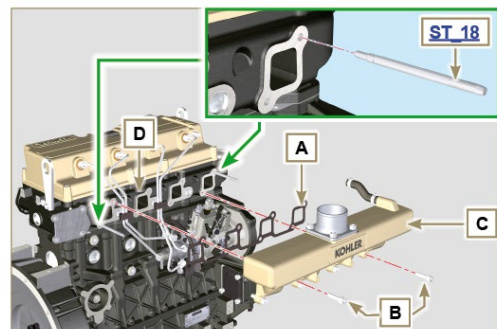


Fig 9.70

9.10 Exhaust manifold assembly



Important

- Replace the self-locking nuts **B** and the metal gaskets **D** between the manifold and the cylinder head every time they are assembly.
 - In the event of mounting the studs **C**, fix (**25 Nm** tightening torque) with **Loctite 2701** on the thread.
1. Check that the contact surfaces **F** are free from impurities.
 2. Insert the gaskets **D** and **E** on the studs **C**.
 3. Position the manifold **A** on the studs **C**.
 4. Fix the manifold **A** on the cylinder head by tightening the self-locking nuts **B** (tightening torque of **25 Nm**).

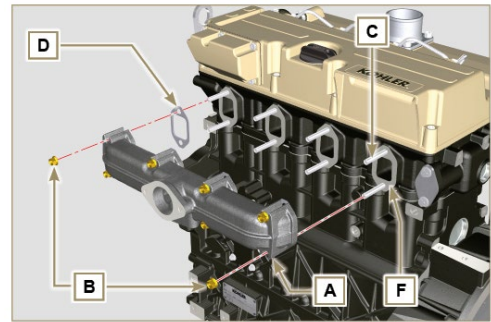


Fig 9.71

9.11 Lubrication circuit assembly

9. 11.1 Oil filter



Important

- In the event of mounting the fitting **U** on the crankcase **S**, fix (**15 Nm** tightening torque) with **Loctite 2701** on the thread.
1. Check that the surface **Q** on crankcase **S** are free from impurities.
 2. Screw the cartridge **A** on the fitting **U** (tightening torque at **15 Nm**).

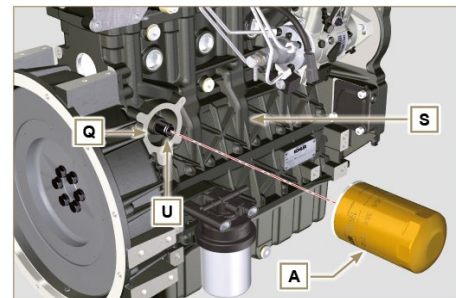


Fig 9.72

9. 11.2 Oil pump

NOTE: Carry out the checks described in **Par. 8.7** before proceeding with the following operations.

1. Check that all contact surfaces between **AL**, **AH**, **AF**, **AG** and **AN** are free of impurities – scratches - dents.
2. When assembling, do not use any type of gasket between **AG** and **AN**.
3. Thoroughly lubricate the seat of the rotors **AF** on the oil pump crankcase **AG** and the two rotors **AH** and **AL**.

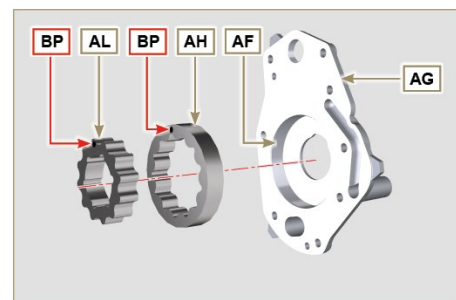


Fig 9.73

4. Insert, inside the seat **AF**, the 2 rotors (in sequence) **AH** and **AL**, respecting the reference **BP** as the picture. (or refer to [Par. 2.10.2](#)).
5. Check that the 2 pins **AM** are inserted properly in the crankcase timing system **AN**.
6. Position the oil pump assembly **AG** using the pin marks **AM**.
7. Fasten the oil pump cover **AG** with the screws **AH** (tightening torque **10 Nm**).

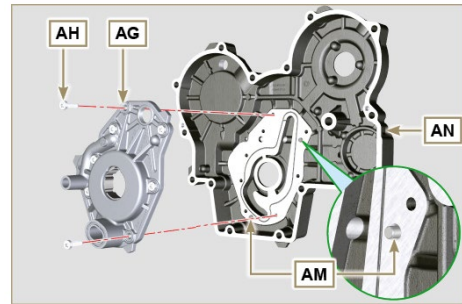


Fig 9.74

9. 11.3 Timing system crankcase



Important

- Always replace the oil seal **J** after each assembly ([ST_14](#)).
 - Always replace the gasket **P** after each assembly.
 - To prepare the surface of the **K** plane for the new application of the sealant, it must be cleaned through the use of:
 - initially **Loctite SF 7200**
 - subsequently **Loctite SF 7063**
 Avoid any contact with the **K** plane and be careful not to compromise the cleaning performed.
1. Distribute a bead of **Loctite 5188**, of about 1mm thickness, on the surfaces **K** of the crankcase **C**.
 2. Make sure that the key **M** ([Fig. 9.76](#)) is inserted properly on the crankshaft and that it is facing upwards.
 3. Lubricate and insert the gasket **P** in the seat of oil pump **Q**.

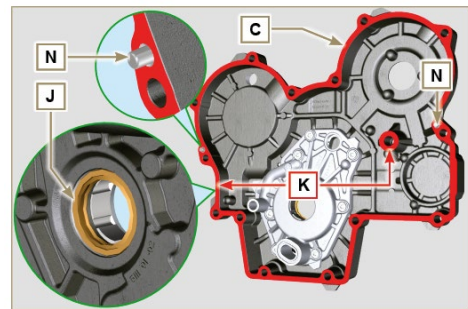


Fig 9.75

4. Tighten the tool **ST_10** on the crankshaft.
5. Check that the 2 pins **N** are properly inserted in the timing system crankcase **C**.
6. Lubricate the gasket **J** with oil and position the crankcase **C** on the crankcase **E**, using the pins **N**, inserting the oil pump **Q** on the crankshaft.

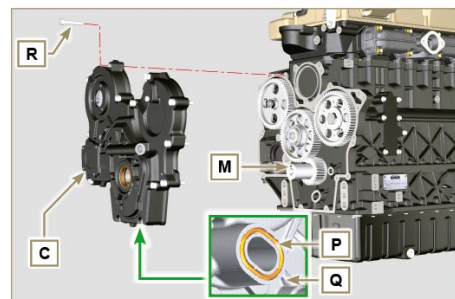


Fig 9.76

7. Fasten the screws **R** (tightening torque of **25 Nm**).

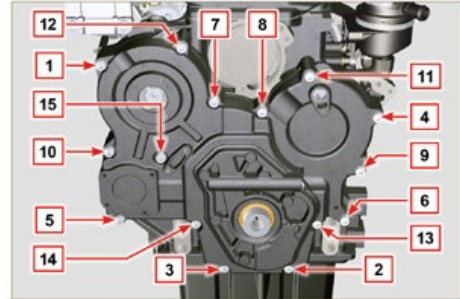


Fig 9.77

9. 11.4 Crankcase oil filler flange Timing System



Important

- Always replace the gasket **BA** after each assembly.
1. Position the gasket **BA** in the seat on the flange **BB**.
 2. Clamp the flange **BB** on the crankcase **BC** with the screws **BD** (tightening torque of **10 Nm - ST_06**).

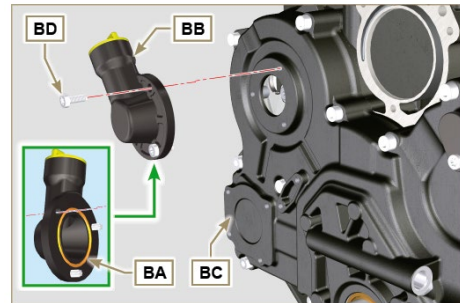


Fig 9.78

9. 11.5 Oil pressure relief valve

1. Lubricate the piston **BE** and fully insert it in the seat **BF**.
2. Insert the spring **BG** in the piston.



Important

- Always replace the gasket **BH** after each assembly.
3. Mount the gasket **BH** on cap **BL**.
 4. Tighten the cap **BL** on the crankcase **BC** (tightening torque of **50 Nm**).

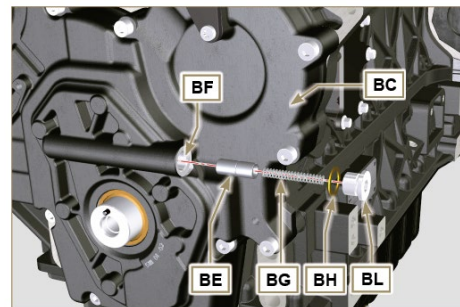


Fig 9.79

9.12 Crankshaft pulley assembly

1. Check that the pin **U** is mounted properly on the crankshaft **V**.
2. Position the pulley **T** on the crankshaft **V** using the pin mark **U**.
3. Apply **Molyslip** grease on the screw thread **Z**.
4. Clamp the pulley **T** with the screw **Z** (tightening torque of **360 Nm**) and remove special tool **ST_34** (Fig. 9.29)

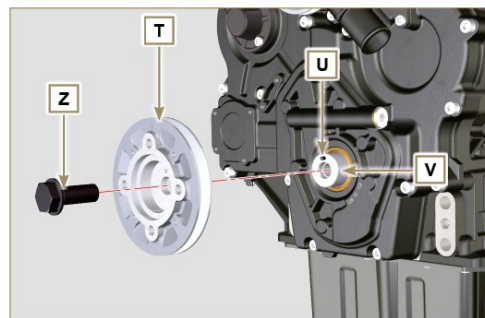


Fig 9.80

9.13 Coolant circuit assembly

9.13.1 Thermostatic valve



Important

- Always replace the gasket **A** after each assembly.
1. Check the condition of the seal gasket **A** and fit it on the thermostatic valve **B**.
 2. Position the thermostatic valve **B** in the seat on the head **C** (detail **D**).
 3. Secure the cover **E** with the screws **F** on the head **C** (tightening torque of **10 Nm**).

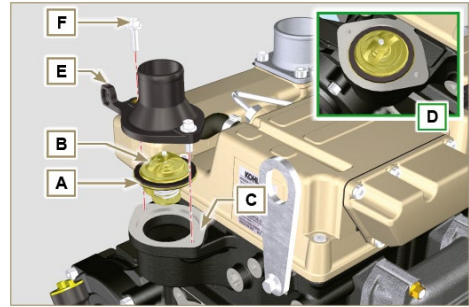


Fig 9.81

9.13.2 Coolant pump



Important

- Always replace the gasket **L** every time it is assembled.
1. Fit the pump **G** with the screws **H** interposing the gasket **L** (tightening torque of **25 Nm**).

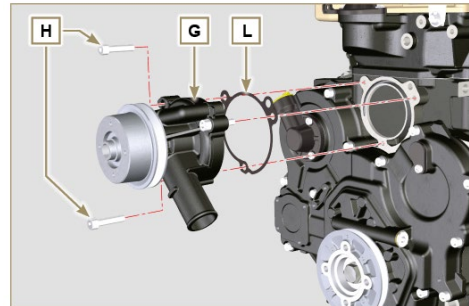


Fig 9.82

9.14 Electric component assembly

9.14.1 Sensors and switches

9.14.1.1 Coolant temperature sensor

1. Secure the sensor **D** onto the head **E** (tightening torque of **20 Nm**).

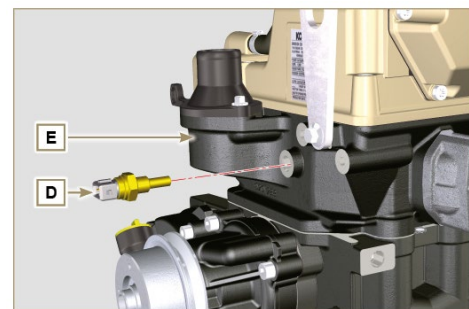


Fig 9.83

9.14.1.2 Oil pressure switch

1. Clamp the oil pressure switch **F** on the crankcase **G** (tightening torque at **35 Nm**).

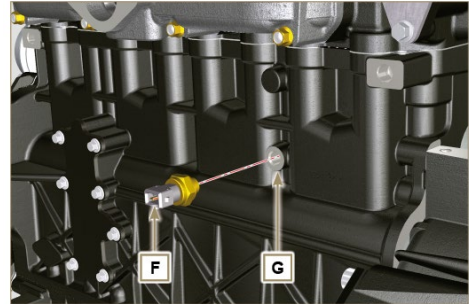


Fig 9.84

9.14.1.3 Fuel filter water detection sensor

1. Lubricate and insert the gasket **AA** on the fitting **AB**.
2. Fix the sensor **AB** onto the cartridge **AC** (tightening torque of **5 Nm**).

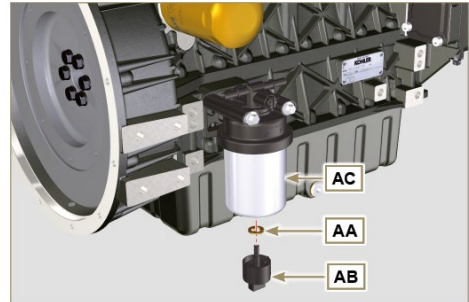


Fig 9.85

9.14.2 Alternator

1. Mount the bracket **M** on the head **N** using the screw **H** and relative washer, without clamping it.
2. Fit the alternator with the screw **A** with the relative washer and spacer **B**.
3. Mount the alternator **C** on the crankcase **Q** tightening the nut **R** up to the stop without clamping it.
4. Mount the screw **L** and relative washer on the alternator **C**, without clamping it.
5. Clamp screw **H** (tightening torque of **25 Nm**).

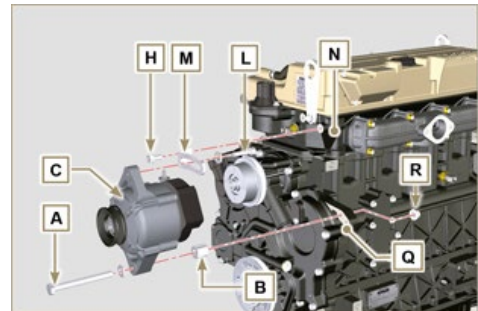


Fig 9.86



Important

- The belt **S** must always be replaced every time it is assembled, even if it has not reached the scheduled hours for replacement.
6. Insert the belt **E** on the pulleys **T**.
 7. Push the alternator **C** in the direction of the arrow **J**.
 8. While tensioning the alternator **C**, first clamp screw **D** (tightening torque at **25 Nm**) and then screw **A** (tightening torque at **69 Nm [thread M10] - 40 Nm [thread M8]**).

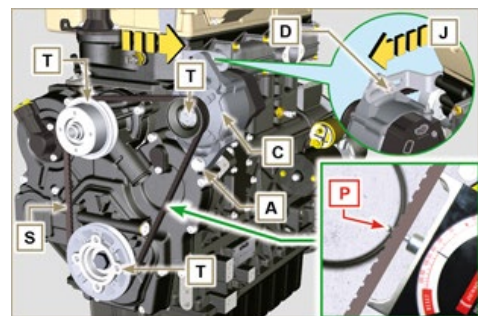


Fig 9.87

9. Check the tension of the belt **S** with the instrument (**DENSO BTG-2**), positioning it in point **P** (the tension must be between **200** and **230 N**).
10. If the tension values do not correspond, tighten screws **A** and **D**, then repeat operations **7**, **8**, **9** and **10**.

9.14.3 Starter Motor



Important

- Remove the tool if still there **ST_34**.
1. Fit the starter **Q** with the screws **R** on to the flange bell **S** (tightening torque of **45 Nm**).

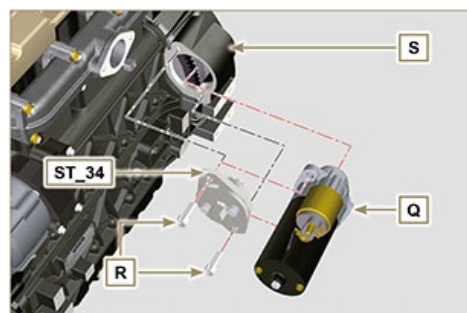


Fig 9.88

9.15 Tightening torques and the use of sealants

Tab. 9.4 - * Alternatively to the capscrew replacements, with "Dri-loc"

BASE CONFIGURATION			
SHORT BLOCK			
Component	Thread (mm)	Torque (Nm)	Sealer
Breather room closing cover fastening capscrew (EXHAUST SIDE)	M6x1	10	
Lower crankcase fastening capscrew	M12x1.25	3 Torque cycles	
1st Cycle		40	
2nd Cycle		70	
3rd Cycle		120	
Lower crankcase fastening capscrew	M8x1.25	2 Torque cycles	
1st Cycle		20	
2nd Cycle		35	
Connecting rod screw	M8x1	2 Torque cycles	
1st Cycle		40	
2nd Cycle		85	
Crankshaft gasket flange fastening capscrew	M6x1	10	
Closing cover fastening capscrew 3 rd PTO	M8x1.25	25	Loctite 2701*
Idle gear lubr. hole cap closure	M14x1.5	30	Loctite 2701*

Coolant drain hole closing cap	M16x1.5	50	
OIL SUMP ASSEMBLY			
Component	Thread (mm)	Torque (Nm)	Sealer
Oil fumes tube	M12x1,5	15	Loctite 648
Oil suction hose fastening capscrew	M6x1	10	Loctite 2701*
Oil sump fastening capscrew	M8x1.25	25	
Oil drain cap	M18x1.5	35	
FLANGE ASSEMBLY (1st PTO)			
Component	Thread (mm)	Torque (Nm)	Sealer
Flange bell fastening capscrew	M10x1,5	50	
Flywheel fastening capscrew	M12x1,25	140	
GEAR DISTRIBUTION			
Component	Thread (mm)	Torque (Nm)	Sealer
Intermediate gear gudgeon fastening screw	M8x1.25	25	
Camshaft gear control fastening capscrew	M10x1	100	
Fastening nut on fuel injection pump gear	M14x1.5	65	
ENGINE CYLINDER HEAD ASSEMBLY			
Component	Thread (mm)	Torque (Nm)	Sealer
Air bleeding cap	M6x1	8	
Lifting brace fastening capscrew	M8x1.25	25	
Injector manifold	M12x1	30	
Cylinder head fastening capscrew	M12x1.25	6 Torque cycles	
1st Cycle		40	
2nd Cycle		70	
3rd Cycle		100	
4th Cycle		90°	
5th Cycle		90°	
6th Cycle		90°	
Rocker arm gudgeon fastening capscrew	M8x1,25	25	
Rocker arm cover fastening capscrew	M6x1	10	
INJECTION SYSTEM			
Component	Thread (mm)	Torque (Nm)	Sealer
Injector brace fastening capscrew	M8x1.25	20	
Waste line fastening drilled capscrew/nipple on Cyl. head	M6x1	14	

Waste line fastening drilled capscrew on injectors	M10x1	15	
Injector side injection tube nuts	M12x1.5	25	
Injection pump side injection tubes nuts	M12x1.5	25	
Injection pump fastening capscrew	M8x1.25	25	Loctite 2701*
Fuel injection pump locking screw	...		
Fuel delivery fastening drilled capscrew (on injection pump)	M10x1	25	
Waste line fastening drilled capscrew (on injection pump)	M10x1	25	
Bleeding screw injection pump (on waste line fastening drilled capscrew)	M6x1	22	
Fuel filter fastening capscrew	M8x1.25	22	

INTAKE MANIFOLD

Component	Thread (mm)	Torque (Nm)	Sealer
Fastening screw intake manifold	M8x1.25	25	
Intake flange fastening capscrew	M8x1.25	25	

EXHAUST MANIFOLD

Component	Thread (mm)	Torque (Nm)	Sealer
Exhaust manifold fixing stud	M8x1.25	25	
Exhaust manifold fixing nut	M8x1.25	25	
Exhaust flange/muffler fixing nut	M8x1.25	25	

LUBRICATION CIRCUIT

Component	Thread (mm)	Torque (Nm)	Sealer
Oil filter fastening union	M20x1.5	15	Loctite 2701*
Oil filter	M20x1.5	15	
Oil pump carter fastening capscrew	TG6	10	
Carter distribution fastening capscrew	M8x1.25	25	
Fastening capscrew for plug on timing system cover	TG6	10	
Side oil load flange fastening capscrew (onto carter distribution)	TG6	10	
Pressure relief valve cap	M16x1.5	50	
Breather system cover fastening capscrew (on rocker arms cover)	M8x1.25	25	

CRANKSHAFT PULLEY

Component	Thread (mm)	Torque (Nm)	Sealer
Crankshaft pulley fastening screw	M16x1.5	360	Molyslip

COOLANT CIRCUIT

Component	Thread (mm)	Torque (Nm)	Sealer
Thermostatic valve cover fastening capscrew	M6x1	10	
Coolant pump fastening capscrew	M8x1.25	25	

ELECTRICAL COMPONENTS

Component	Thread (mm)	Torque (Nm)	Sealer
Coolant temperature sensor	M12x1.5	20 max.	
Oil pressure switch	M12x1.5	35	
Sensor for water presence in fuel		5	
Alternator bracket fastening capscrew	M8x1.25	25	
Alternator fastening capscrew	M8x1.25	40	
Alternator fastening capscrew	M10x1.5	69	
Starter motor fastening capscrew	M10x1.5	45	
Supply cable fastening nut (starter motor)	M8x1.25	10	

CONTROLS

Component	Thread (mm)	Torque (Nm)	Sealer
Accelerator bracket fastening capscrew	M6x1	10	

* Alternatively to the capscrew replacements, with "Dri-loc"

OPTIONAL COMPONENTS (CAP. 11)
OIL DIPSTICK ON CYLINDER HEAD

Component	Thread (mm)	Torque (Nm)	Sealer
Oil dipstick tube fastening capscrew	M6x1	10	

HEATER

Component	Thread (mm)	Torque (Nm)	Sealer
Flange intake with heater fastening capscrew	M8x1.25	25	

ALTERNATOR WITH POLY-V BELT

Component	Thread (mm)	Torque (Nm)	Sealer
Pulley fastening capscrew	M10x1.5	48	
Pulley positioning blocking nut capscrew	M10x1.5	45	
Alternator brace fastening capscrew	M8x1.25	25	
Alternator fastening capscrew (upper)	M8x1.25	25	
Alternator fastening capscrew (lower)	M8x1.25	40	
Pulley sliding plate fastening capscrew	M8x1.25	25	

IDLE GEAR (FOR 3th /4th PTO)

Component	Thread (mm)	Torque (Nm)	Sealer
Gear drilled fastening capscrew	M14x1.5		Molyslip

3^a PTO

Component	Thread (mm)	Torque (Nm)	Sealer
Pump support fastening capscrew	M8x1.25	25	Loctite 2701*
Pump fastening capscrew	M8x1.25	25	
4 ^a PTO			
Component	Thread (mm)	Torque (Nm)	Sealer
Grooved crankshaft support fastening capscrew	M8x1.25	25	Loctite 2701*
Cover fastening capscrew (3rd PTO side)	M8x1.25	25	
Sump support fastening capscrew	TG6	10	
Pump fastening capscrew	M8x1.25	25	
BALANCE SHAFTS (4 CYLINDERS)			
Component	Thread (mm)	Torque (Nm)	Sealer
Housing closing panel fastening capscrew	M6x1	8	
Shafts support fastening capscrew	M10x1.5	50	
REMOTE OIL FILTER			
Component	Thread (mm)	Torque (Nm)	Sealer
Head fixing joint on crankcase	M20x1.5	25	Loctite 2701
Crankcase head nipple and oil filter support	M14x1.5	40	
Tube union on crankcase head	G3/8	30	
Tube union on filter support	G3/8	35	
Oil filter	M20x1.5	20	
Filter support head air bleeding cap	M8x1.25	25	
INTAKE CIRCUIT			
Component	Thread (mm)	Torque (Nm)	Sealer
Air filter support plate fastening capscrew (on flange bell)	M8x1.25	25	
Air filter support fastening capscrew	M8x1.25	25	
EXHAUST CIRCUIT			
Component	Thread (mm)	Torque (Nm)	Sealer
Muffler brace support fastening capscrew	M8x1.25	25	
Muffler fastening capscrew on muffler	M8x1.25	25	
Muffler fastening nut	M8x1.25	25	
COOLING CIRCUIT			
Component	Thread (mm)	Torque (Nm)	Sealer
Blower fastening capscrew	M6x1	10	
Radiator support fastening capscrew	M16x1.5	150	
Shroud radiator fastening capscrew	M6x1	10	
Radiator lower brace fastening capscrew	M8x1.25	25	
Radiator on anti-vibrating	M8x1.25	25	
Vibration-damping nut fixing (on radiator support)	M8x1.25	25	
Anti-vibrating and brace fastening capscrew (upper)	M6x1	10	

Upper brace fastening capscrew (on engine cylinder head)	M8x1.25	25	
Side bulkheads fastening capscrew	M6x1	10	
ENGINE SUPPORT			
Component	Thread (mm)	Torque (Nm)	Sealer
Side feet fastening capscrew (on flange bell or crankcase)	M12x1.75	50	
Rear feet fastening capscrew	M16x1.5	200	

10 FLUIDS FILLING INFORMATION

10.1 Engine oil



Important

- Before proceeding with operation, read [Par. 3.3.2](#).
- Do not use the engine with the oil level below the minimum.

1. Loosen the oil filler cap **A** or the oil filler cap **C** if the cap **A** is not accessible.
2. Add the type and amount of oil recommended ([Tab. 2.2](#)).

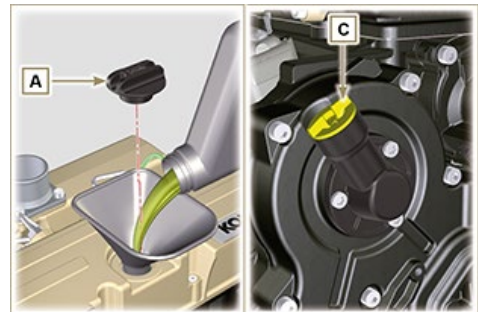


Fig 10.1

3. Remove the oil dipstick **B** and check that the level is up to but does not exceed the **MAX**.
4. If the oil level is not at **MAX**, insert more oil until the **MAX** level is reached as indicated on the dipstick.
5. Re-tighten the cap **A** or **C**.

NOTE: See the [Par. 11.1](#) for the various configurations of the oil dipstick.

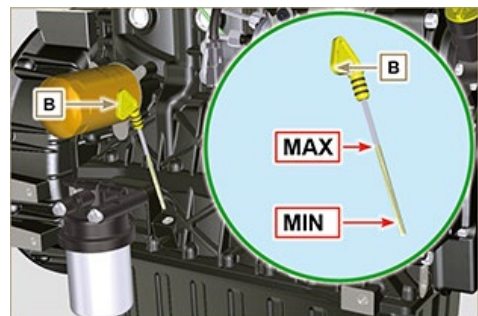


Fig 10.2

10.2 Coolant



Important

- Before proceeding with operation, read [Par. 3.3.2](#).

1. Screw the cap. **G**, replacing the copper gasket (Tightening torque of **50 Nm**).

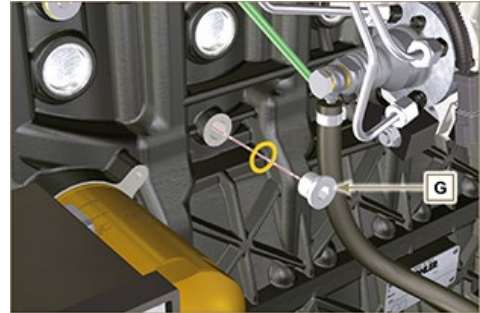


Fig 10.3

2. Tighten the cap **E**, replacing the copper gasket **D**.

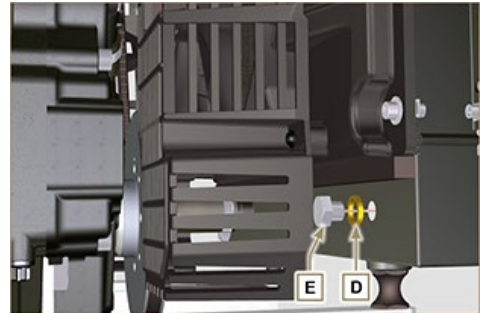


Fig 10.4

3. Refill the radiator with coolant (refer to [Par. 2.6](#) for the liquid specifications).
4. Top liquid up until the pipes inside the radiator are covered by about 5 mm.
5. For engines equipped with separate expansion tank, pour in fluid until reaching the max level mark.
6. Loosen the screw **F** on the head **H**, release any air and tighten the screw **F** (Tightening torque of **8 Nm** - **Fig. 10.7**).
7. Start the engine without the radiator cap **A** or the expansion tank (**C**) cap **B**.

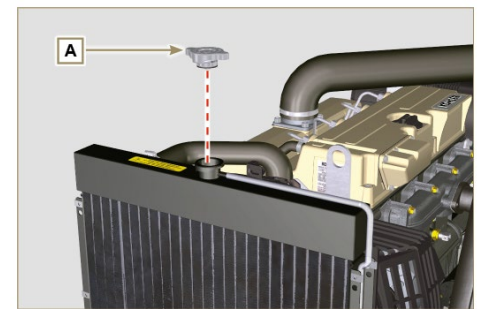


Fig 10.5

8. Keep it running at idle speed until the cooling liquid level goes down and becomes steady (the waiting times varies according to the ambient temperature).
9. Stop the engine and allow it to cool.
10. If there is an expansion tank (**C**) top liquid up to the mark **MAX**.
11. Without expansion tank top liquid up until the pipes inside the radiator are covered by 5 mm. Do not overfill the radiator, but leave room for the coolant to expand.
12. Tighten the radiator cap **A** or the expansion tank (**C**) cap **B**.

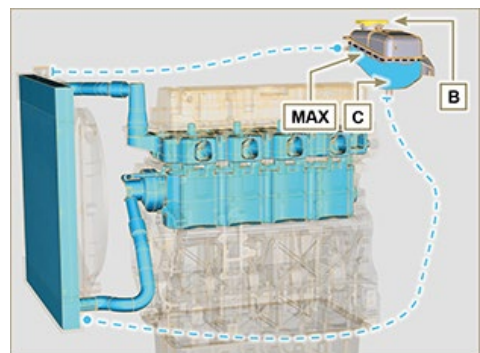
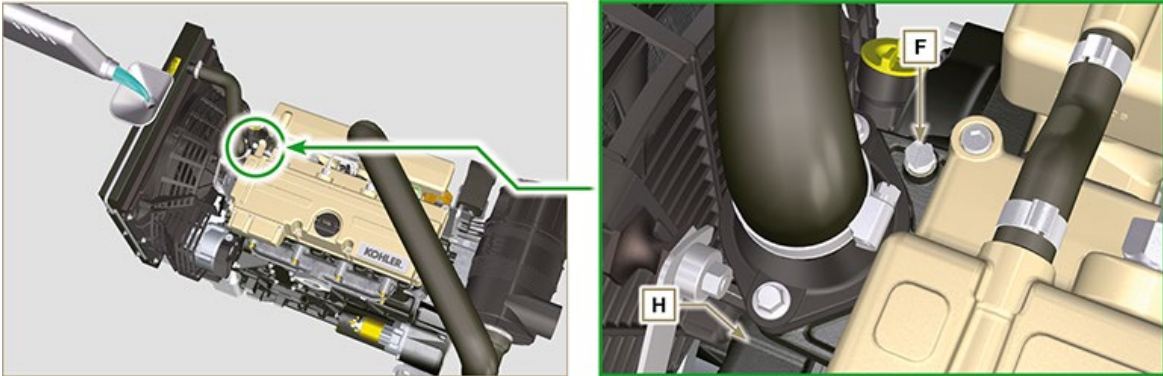


Fig 10.6

**Warning**

- Before starting make sure that the radiator cap and expansion tank cap, if present, are installed correctly to avoid spillage of liquid or vapour at high temperatures.
13. After a few hours of operation stop the engine and allow it to cool.
Check and top up the coolant liquid.

**Fig 10.7**

11 INFORMATION ABOUT OPTIONAL COMPONENTS

11.1 Oil dipstick in cylinder head



Important

- Before proceeding with operation, read [Par. 3.3.2.](#)

11.1.1 Check

1. Pull out the dipstick **B** in the direction of the arrow **A**.
2. Check that the mark left by the oil on the dipstick is between the **MIN.** and **MAX.** notches.

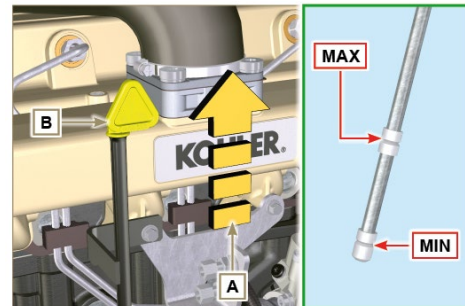


Fig 11.1

11.1.2 Replacement

11.1.2.1 Disassembly

1. Undo the screw **D**.
2. Pull out the oil dipstick hose **E** in the direction of the arrow **F**.

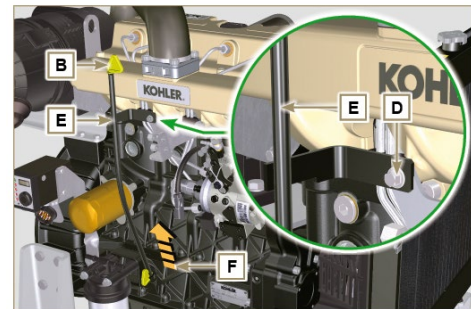


Fig 11.2

11.1.2.2 Assembly



Important

- Always replace the gasket **G** every time it is disassembled.
1. Insert the gasket **G** in the seat **K** of the hose **E**.
 2. Insert the hose **E** in the crankcase **H**.

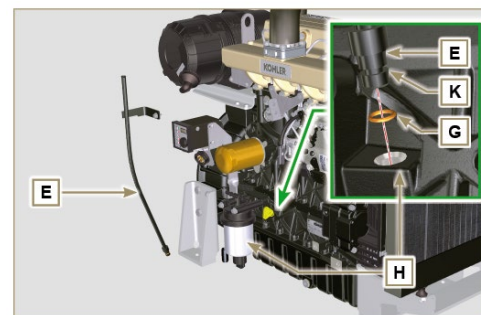


Fig 11.3

3. Tighten the oil dipstick hose **E** using the screw **D** on the manifold **L** (Tightening torque of **10 Nm**).

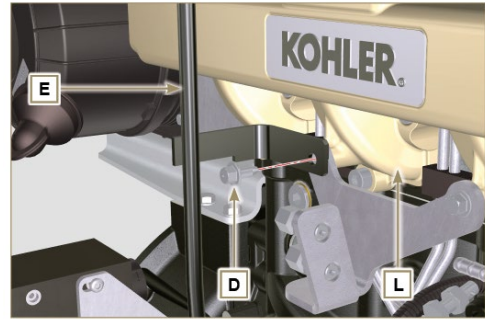


Fig 11.4

NOTE: Check the integrity of the gaskets **J**.

4. Insert the dipstick **B** inside the hose **E**.

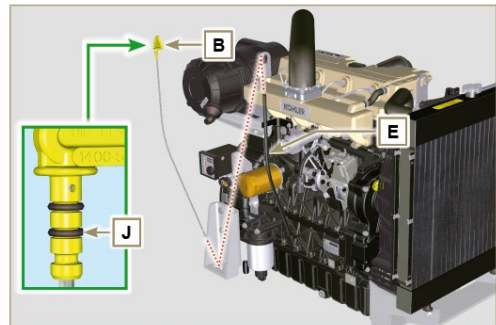


Fig 11.5

11.2 Heater (replacement)



Important

- Before proceeding with operation, read **Par. 3.3.2**.

11.2.1 Disassembly

1. Undo the screws **A** and the relevant washers and remove the earth cable **B**.
2. Remove the flange **C** and the manifold **D**.
3. Remove the heater **E** and the relevant gaskets **F**.

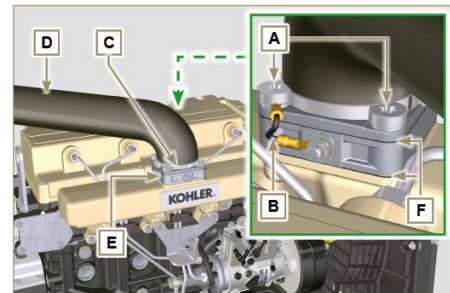


Fig 11.6

11.2.2 Assembly



Important

- Always replace gaskets **F**, with each assembly.
1. In sequence, fit the manifold **G** with the gasket **F**, the new heater **E**, the second gasket **F**, the flange **C**, the washers **H**, the screws **A** and the cable **B**.
 2. Secure the flange **H** with the screws **A** (tightening torque at **22 Nm**).
 3. Secure the earth cable **B** with the nut **J** and the relevant washer on the heater **E**.

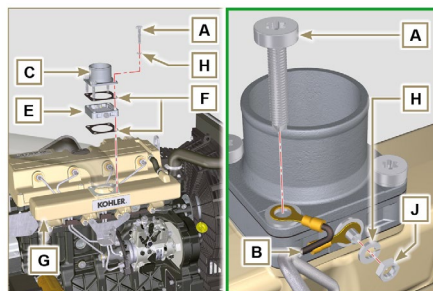


Fig 11.7

11.3 Poly-V alternator belt (replacement and adjustment)



Important

- Before proceeding with operation, read [Par. 3.3.2](#).

1. Loosen the nut **B** and manually tighten the screw **C** until it just touches the pulley pin **D** (Fig. 11.9).

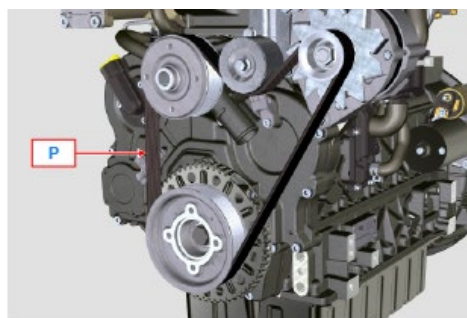
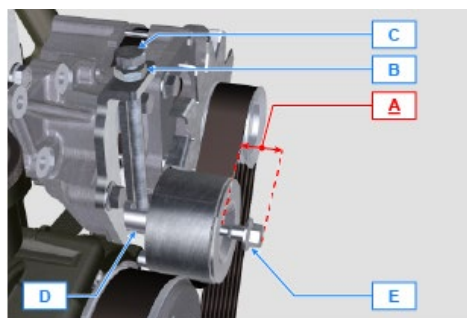


Fig 11.8

2. Untighten the screw **E** by around **32mm (A)**.
3. Untighten the screw **C**.

NOTE: The belt tensioner pulley **F** should move towards the arrow **G**. If it does not, please move it manually.



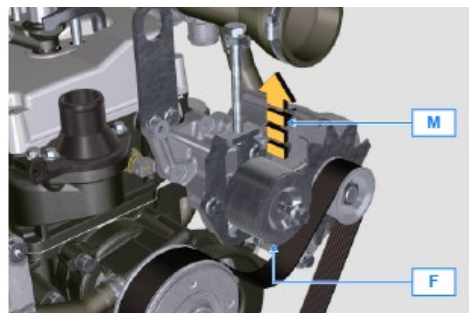


Fig 11.9

4. Remove the V-Belt **H** and install the new one.

NOTE: Ensure that the internal profile of belt **H** is properly inserted into the grooves of the pulley **A** (as illustrated in **D1** e **D2**).

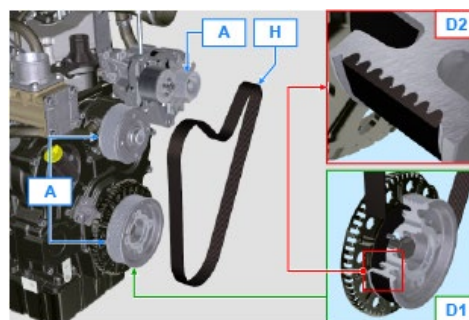


Fig 11.10

5. Tighten capscrew **C**, to shift gudgeon **D** fully to the bottom of the grooved guide.
6. Tighten capscrew **E** (tightening torque at **45Nm**).
7. Hold the screw **C** still with a key, and tighten the screw **B** on the plate **L** to secure the screw **C** (tightening torque at **45Nm**).
8. Check, in point **P** (**Fig. 11.8**), the tension of the belt. Check by the appropriate tool that at point **p** the tension value is between **149 and 196 Hz**.

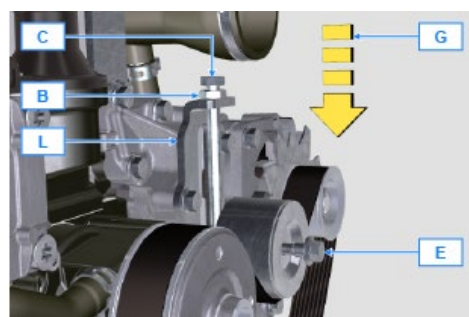


Fig 11.11

NOTE: After the engine has been in operation for around 15 minutes, repeat point **8**.

11.4 Tightening pulley and alternator for Poly-V belt



Important

- Before proceeding with operation, read **Par. 3.3.2**.

11.4.1 Disassembly

1. Perform the operations from **point 1 to 3 of Par. 11.3.**
2. Remove the belt **H** (**Fig. 11.10**).
3. Undo and remove the screw **A**.
4. Fully undo the screw **B** and remove the tightening pulley **C**.

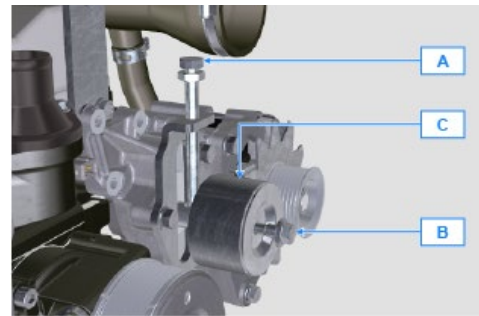


Fig 11.12

5. Undo the screws **D** and remove the plate **E** and the pin **F**.

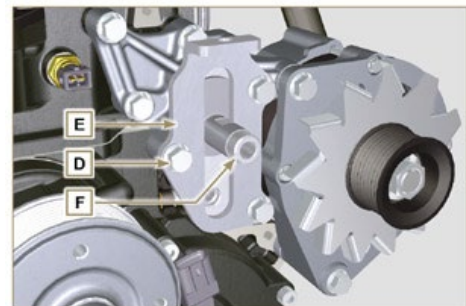


Fig 11.13

6. Undo the screws **G and H** remove the alternator **L**.

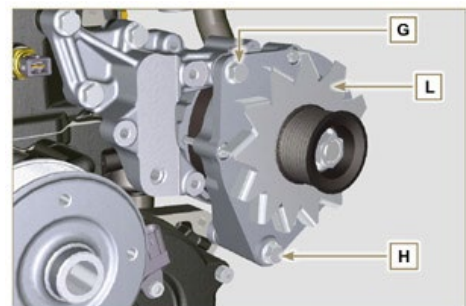


Fig 11.14

7. Undo the screws **M** and remove the bracket **N**.

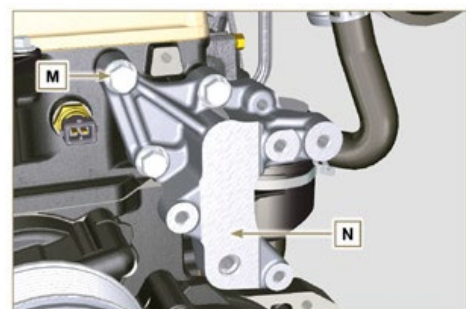


Fig 11.15

11.4.2 Assembly

1. Secure the bracket **N** using the screws **M** on the cylinder head **P** (tightening torque at **25 Nm**).

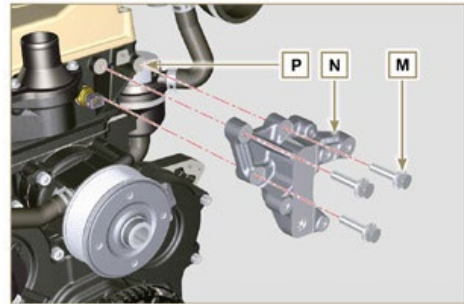


Fig 11.16

2. Insert the screw **H** into the fixing hole on the alternator **L**.
3. Insert the spacer **R** on the screw **H** (between the alternator and crankcase).
4. Tighten the screw manually **H** onto the crankcase **Q**.
5. Orientate the second fixing hole of the alternator **L** with the hole of the bracket **N**, secure the alternator **L** using the screw **G** (tightening torque at **25 Nm**) onto the bracket **N** and then the screw **H** (tightening torque at **25 Nm**).

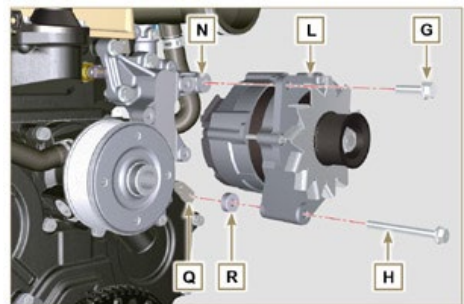


Fig 11.17

6. Insert the pin **F** in the plate slot **E**.
7. Orientate the pin **F** with the surface **S** (support for screw **A**) upwards.
8. Secure the plate **E** using the screws **D** on the bracket **N** (tightening torque at **25 Nm**).

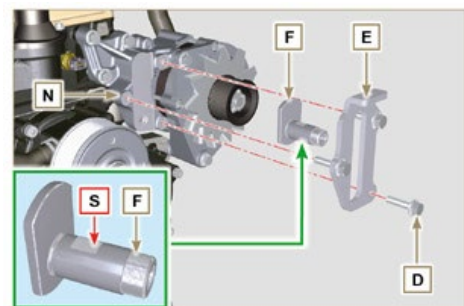


Fig 11.18

9. Insert the screw **B** in the plate **C1** and pulley **C**.
10. Manually tighten the screw **B** onto the pin **F** up to the stop; Undo the screw **B** again by one turn.

NOTE: The screw **B** must protrude by about 32 mm (**A**) from the surface of the tightening pulley **C** (see detail **X**).

11. Install the new belt **H** (Fig. 11.10).
12. Tighten the screw **A** onto the plate **E** up to the stop on the pin **F**.
13. Perform the operations from point **6 to 8 of Par. 11.3**.

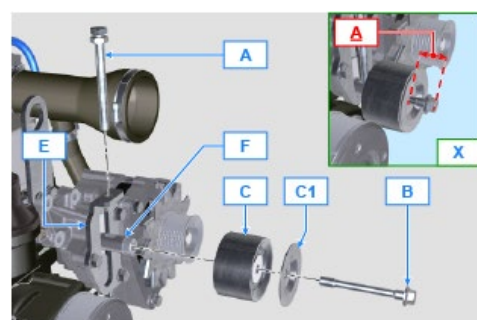


Fig 11.19

11.5 Idler gear (for 3rd / 4th PTO)



Important

- Before proceeding with operation, read [Par. 3.3.2.](#)

11.5.1 Disassembly

1. Undo the screw **A** and remove the gear unit **B**.

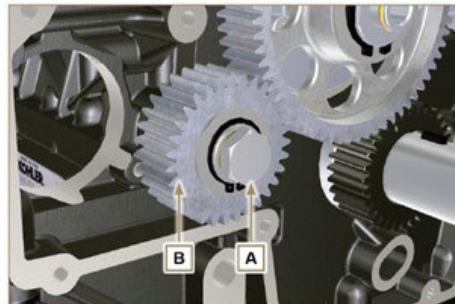


Fig 11.8

2. Remove the retainer ring **C** from the seat of the pin **D**.
3. Remove the shoulder washer **E**, the gear **B**, the shoulder ring **F** and the bushing **G** from the pin **D**.

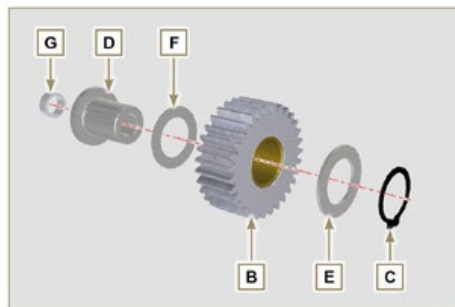


Fig 11.9

11.5.2 Assembly

1. Fit into the pin **D**:
 - The shoulder ring **F** (of least thickness)
 - The gear **B**
 - The shoulder ring **E**
 - The retainer ring **C**.
2. Insert the bushing **G** on the crankcase **L**.

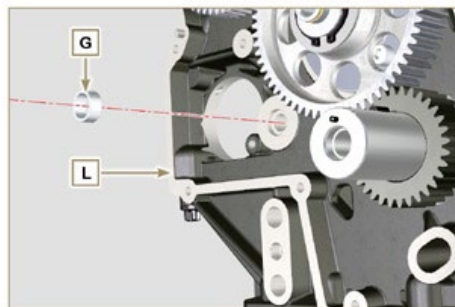


Fig 11.10



Important

- Always replace the washer **H** every time it is disassembled.
Modified component, see service letter 700019 - 700021.
- Check that the perforated screw **A** is free from impurities inside it.

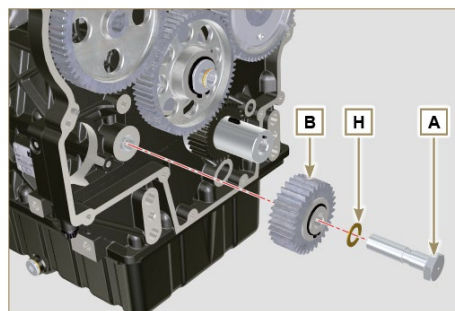


Fig 11.11

3. Position the gear unit **B** on the hole **J** using the bushing **G** to centre.
4. Secure the gear **B** using the screw **A** inserting the washer **H** (tightening torque at **see service letter 700019 - 700021**).

11.6 3rd PTO (replacement)

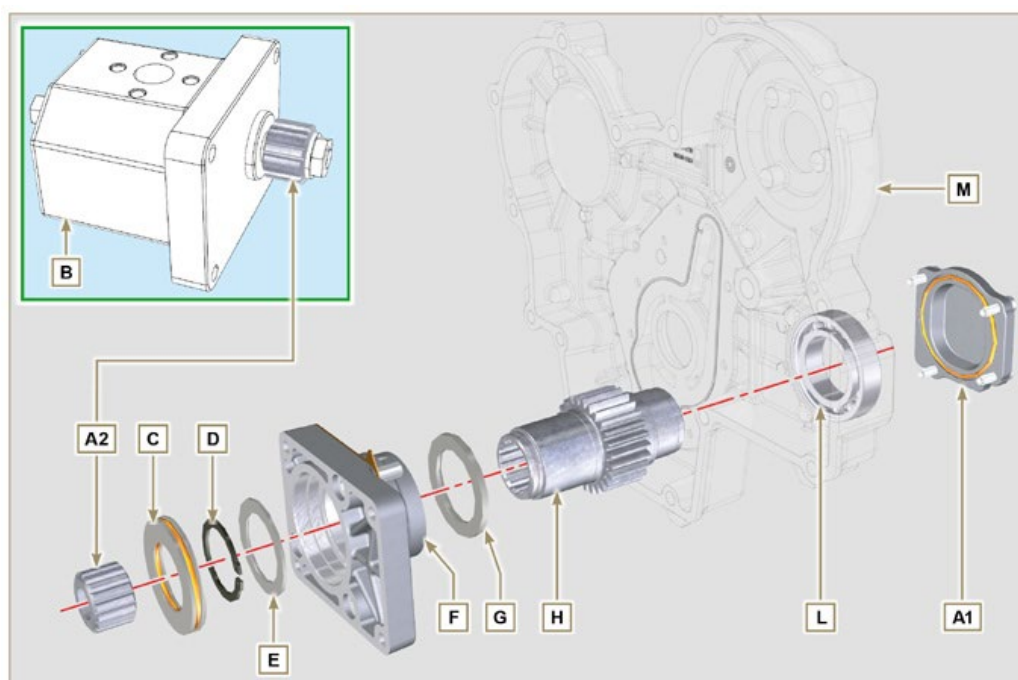


Fig 11.12



Important

- Before proceeding with operation, read **Par. 3.3.2**.

11.6.1 Disassembly

1. Undo the screws **A** and remove the pump **B**.

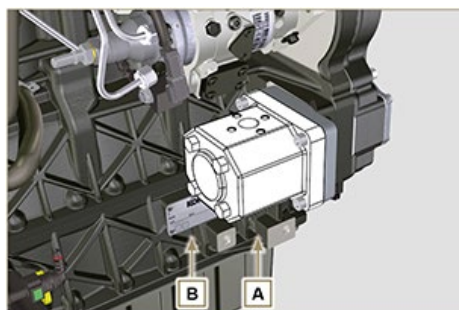


Fig 11.13

2. Remove the centring ring **C** and the relative gaskets
3. Undo the screws **N**.

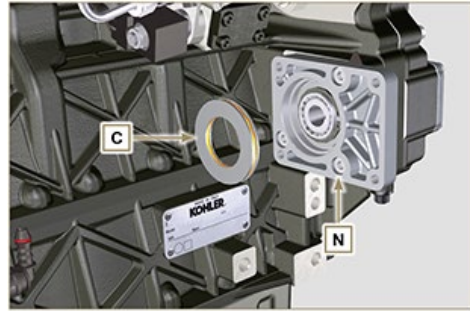


Fig 11.14

4. Remove the flange **F** with the components **D**, **E**, **G** and **H** in the direction of the arrow **P**.
5. Remove the gasket **J**.

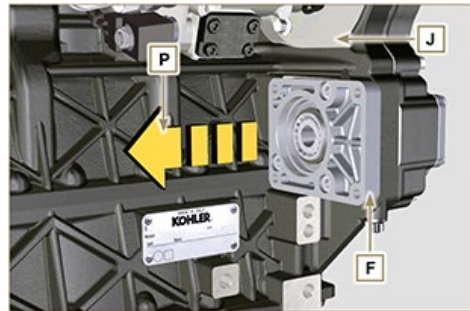


Fig 11.15

6. Remove the retainer ring **D** and the shoulder washer **E**.
7. Remove the gear **H** and the shoulder ring **G** from the flange **F** in the direction of the arrow **Q**.

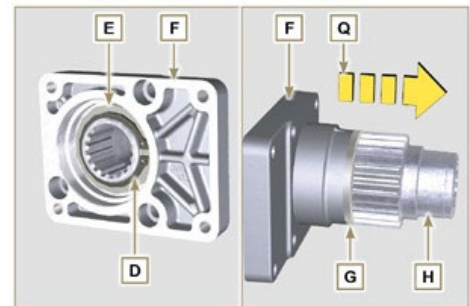


Fig 11.16

11.6.2 Assembly



Important

- Always replace the gasket **J** after each assembly.
- Lubricate the gear **H** with oil.
- It is mandatory to replace the screws **N** or apply a few beads of **Loctite 2701**.

1. Insert the gear **H** in the flange **F** in the direction of the arrow **R** inserting the shoulder ring **G**.
2. Insert the shoulder ring **E** on the flange **F** and clamp the gear **H** using the retainer ring **D**.

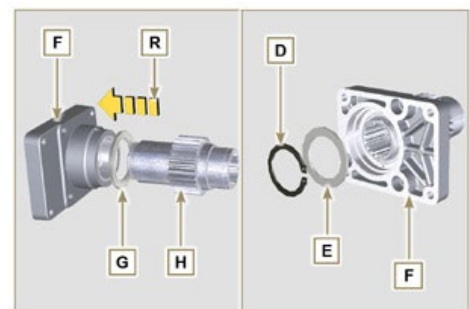


Fig 11.17

- Position the flange **F** on the crankcase **K** inserting the gasket **J**, and inserting the gear **H** up to the stop on the bearing **L** (Fig. 11.31).

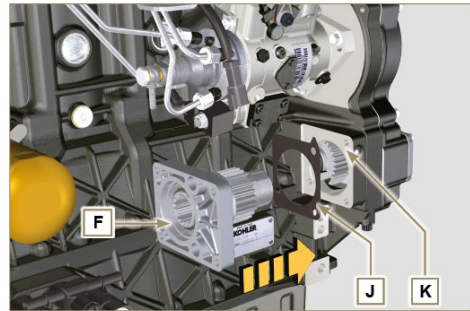


Fig 11.18

- Secure the flange **F** using the screws **N** (tightening torque at **25 Nm**).



Important

- Always replace the gaskets **P** and **Q** at each assembly.
- Insert the centring ring **C** in the flange **F** up to the stop.
 - Insert the pump **B** on the flange **F** engaging the gear **H**.
 - Secure the pump **B** using the screws **A** on the flange **F** (tightening torque at **25 Nm**).

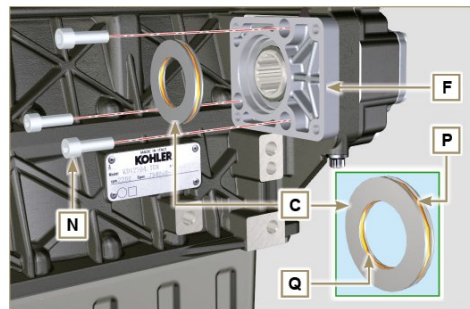


Fig 11.19

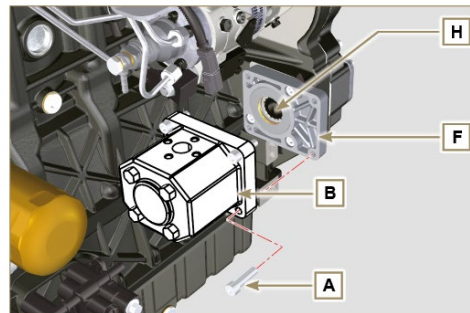


Fig 11.20

11.7 4th PTO (replacement)

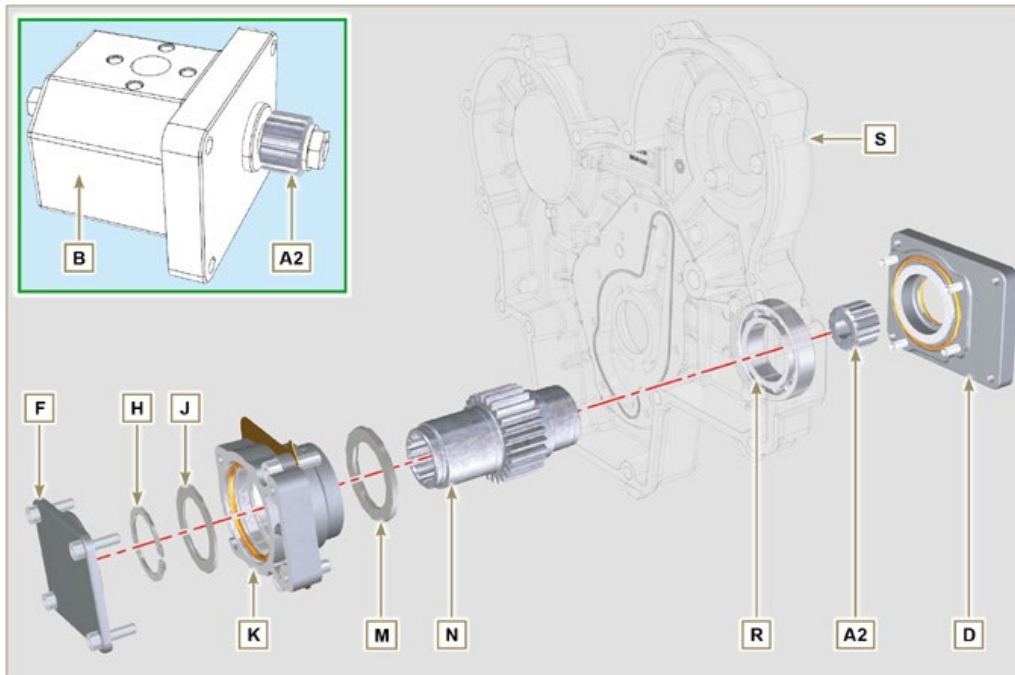


Fig 11.21



Important

- Before proceeding with operation, read [Par. 3.3.2.](#)

11.7.1 Disassembly

1. Undo the screws **A** and remove the pump **B**.

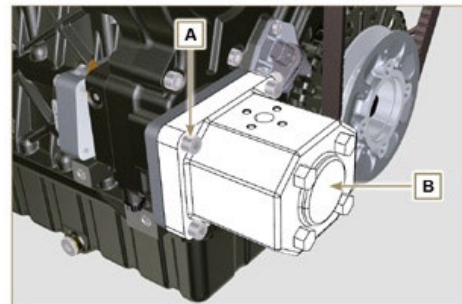


Fig 11.22

2. Undo the screws **C** and remove the flange **D**.

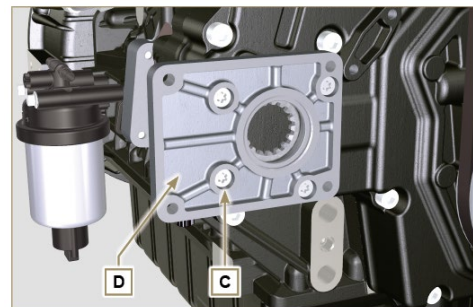


Fig 11.23

3. Undo the screws **E** and remove the cover **F**.

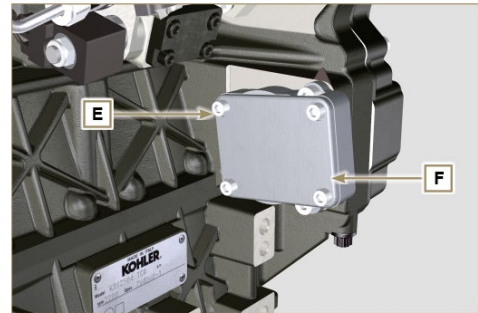


Fig 11.24

4. Undo the screws **G** and remove the flange **K** with the components **H**, **J**, **M** and **N**.

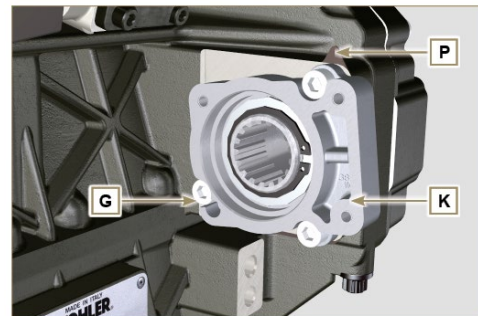


Fig 11.25

5. Remove the retainer ring **H** and the shoulder ring **J** from the flange **K**.
6. Remove the gear **N** and the shoulder ring **M** from the flange **K**.

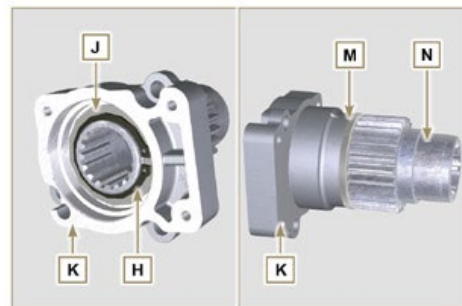


Fig 11.26

11.7.2 Assembly



Important

- Always replace the shoulder ring **J** after each assembly.
- Lubricate the gear **N** with oil.
- It is mandatory to replace the screws **G** or apply a few beads of **Loctite 2701**.

1. Insert the gear **N** in the flange **K** in the direction of the arrow **W** inserting the shoulder ring **M**.
2. Insert the shoulder ring **J** on the flange **K** and clamp the gear **N** using the retainer ring **H**.

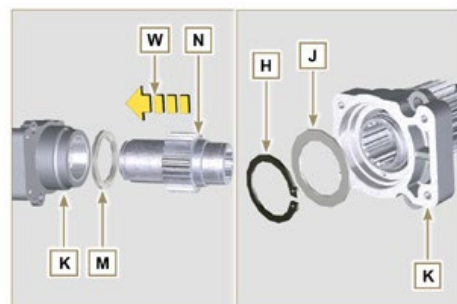


Fig 11.27

3. Position the flange **K** on the crankcase **Q** inserting the gasket **P**, and inserting the gear **N** up to the stop on the bearing **R** (Fig. 11.41).
4. Secure the flange **K** using the screws **N** (tightening torque at **25 Nm**).

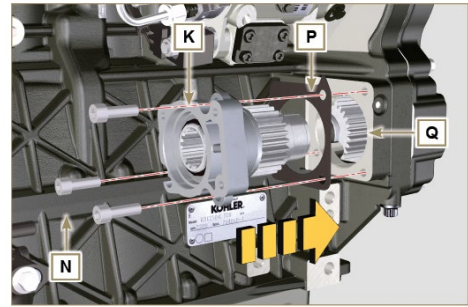


Fig 11.28



Important

- Always replace the gasket **V** after each assembly.
5. Insert the gasket **V** on the cover **F**, insert and position the cover **F** on the flange **K**.
 6. Secure the cover **F** using the screws **E** on the flange **K** (tightening torque at **25 Nm**)

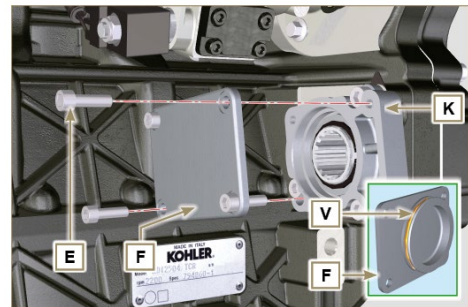


Fig 11.29



Important

- Always replace the gasket **T** after each assembly.
7. Position and secure the flange **D** using the screws **C** on the crankcase **S** (tightening torque at **10 Nm**).

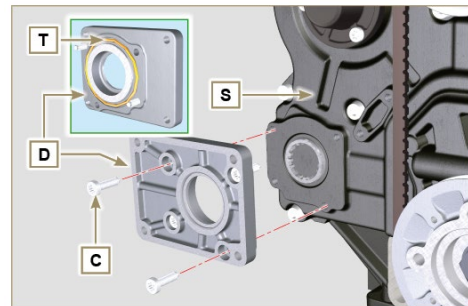


Fig 11.30



Important

- Always replace the gasket **U** after each assembly.
8. Position the gasket **U** on the flange **D**.
 9. Secure the pump **B** using the screws **A** on the flange **D** (tightening torque at **25 Nm**).

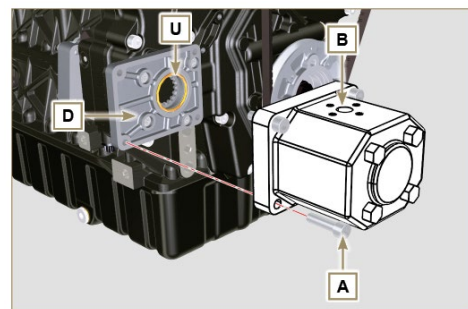


Fig 11.31

11.8 3rd + 4th PTO (configurations)

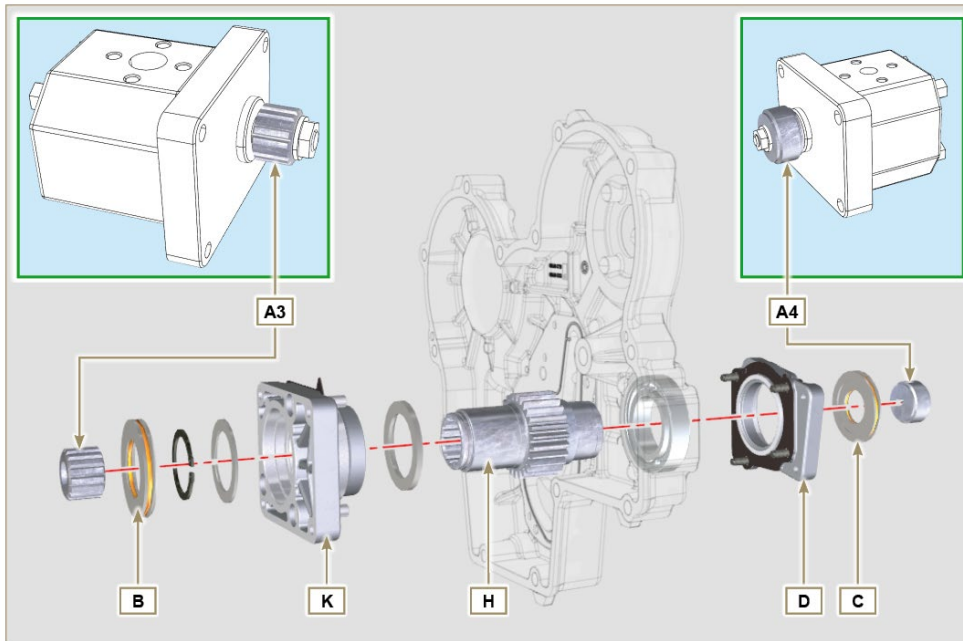


Fig. 11.32

11.8.1 Information

Hydraulic pumps on the 3rd and 4th PTO can be installed at the same time.
 In some configurations, there is also the centering ring **C** on the 4th PTO.



Important

- For disassembly or installation, refer to [Par. 11.5](#), [Par. 11.6](#) and [Par. 11.7](#).
- Always replace the gasket of the rings **B** and **C** and flanges **D** and **K** at each assembly.
- Lubricate the gear **H** with oil.

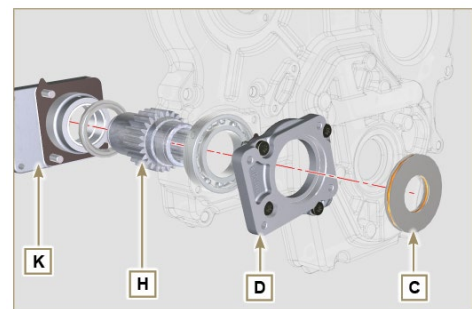


Fig. 11.33

11.9 Balancer device (replacement)



Important

- Before proceeding with operation, read [Par. 3.3.2](#).

11.9.1 Disassembly

1. Perform the operations described in [Par. 5.2](#).
2. Undo the screws **A** and remove the oil sump **B**.

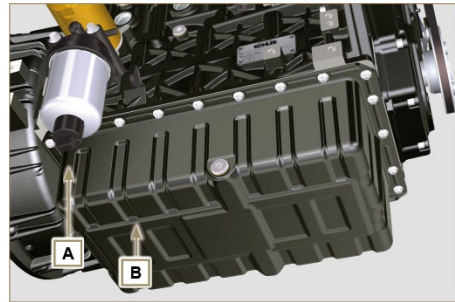


Fig 11.34

3. Undo the screws **C** and remove the hose **D**.

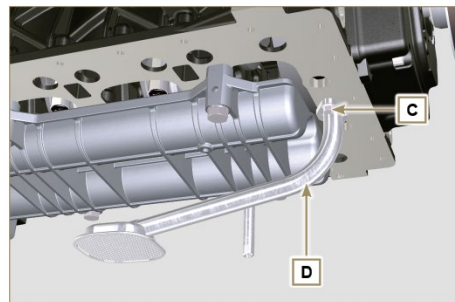


Fig 11.35

4. Undo the screws **E** and remove the shaft support box **F**.

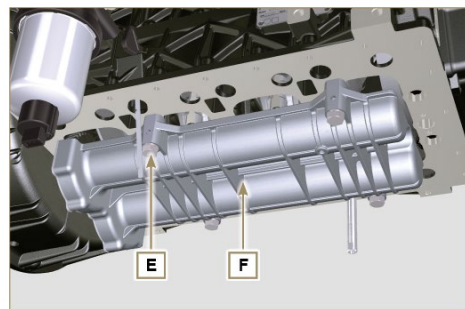


Fig 11.36

5. Undo the screws **G** and remove the plate **H**.

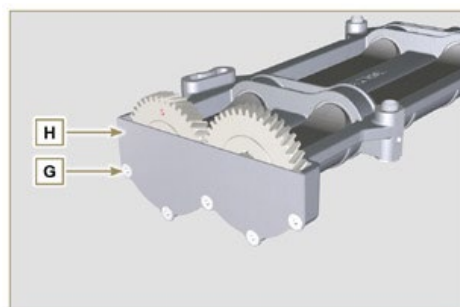
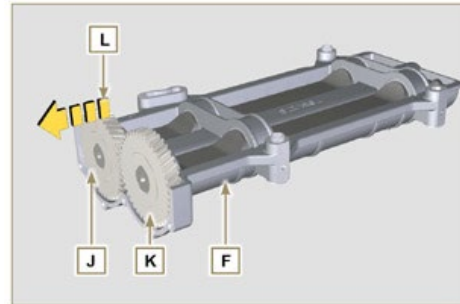


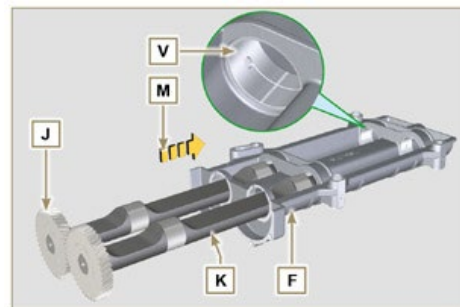
Fig 11.37

- Remove the shafts **J** and **K** in the direction of the arrow **L** from box **F**.

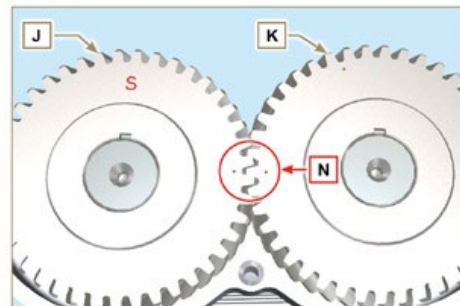

Fig 11.38

11.9.2 Assembly

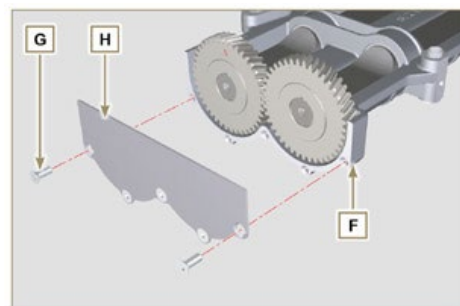
- Lubricate the bushings **V** with **Molikote** grease.
- Insert the shafts **J** and **K** inside the box **F** in the direction of the arrow **M**.


Fig 11.39

- Make sure that the shafts **J** and **K** inside the box **F** observe the marks **N** and that the shaft **J** with the gear indicated by letter "S" stamped on it is on the left with respect to the box **F**.


Fig 11.40

- Secure the plate **H** using the screws **G** on the box **F** (tightening torque at **8 Nm**).


Fig 11.41

5. Manually tighten the retainer screw **ST_15** on the box **F** by slightly rotating the shaft **K**, centring the hole on it using the **ST_15**, to lock the device.

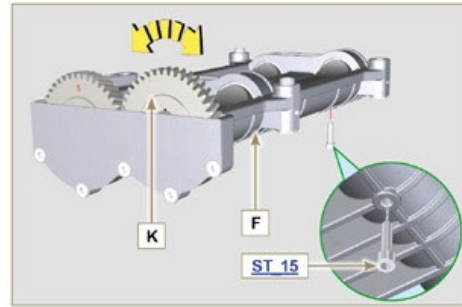


Fig 11.42

6. Rotate the crankshaft and clamp it on the TDC (**Ref. P** upwards) using the tool **ST_34** secured in place of the starter motor (detail **Q**).

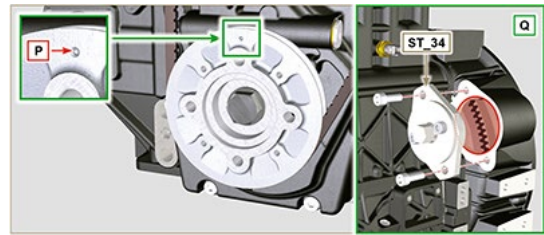


Fig 11.43

7. Position the box **F** on the surface **R** of the crankcase observing the reference bushings.
8. Secure the box **F** using the screws **E** and **Loctite 242** inserting the washers **U** (tightening torque at **50 Nm**).
9. Remove the retainer screw **ST_15** from the box **F**.

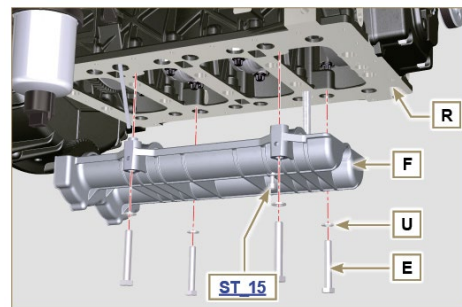


Fig 11.44



Important

- Check that the retainer screw **ST_15** is not present on the box **F** (**Fig. 11.42**).
 - Always replace the gasket **W** after each assembly.
 - Lubricate the gasket **W** with oil before assembling it.
10. Insert the gasket **W** in the seat on the flange of the oil hose **D**.
 11. Secure the oil intake hose **D** using the screws **C**.
 12. Perform all operations described in **Par. 9.4.3** to assemble the oil sump.

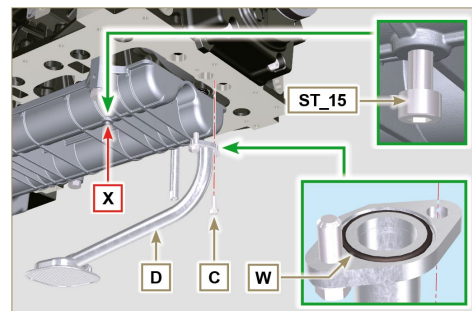


Fig 11.45

11.10 Air filter (cartridge replacement)



Important

- Before proceeding with operation, read [Par. 3.3.2](#).

1. Release the two hooks **A** and remove the cover **B** from the body **C**.
2. Remove the cartridges **D**.

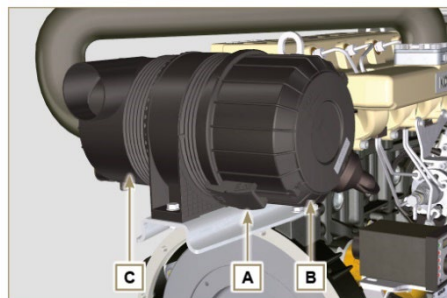


Fig 11.46

3. Insert the new cartridge **D** and both of them inside the filter body **C**.
4. Secure the cover **B** via the hooks **A**.

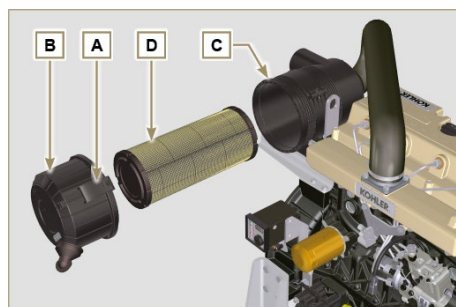


Fig. 11.47

11.11 Remote oil filter (disassembly and assembly)



Important

- **Modified component, see service letter 700018.**

11.11.1 Disassembly

1. Perform the operations described in [Par. 5.2](#).



Important

1. Before proceeding with operation, read [Par. 3.3.2](#).
2. For the replace the cartridge, please refer to operation number **6 (Par. 11.9.1)** and **2 (Par. 11.9.2)**.
3. For the disassembly of the pipes **B** and **C**, lock with a tool the fittings **K, H (Fig. 11.49)** and **L (Fig. 11.50)** in order to prevent their

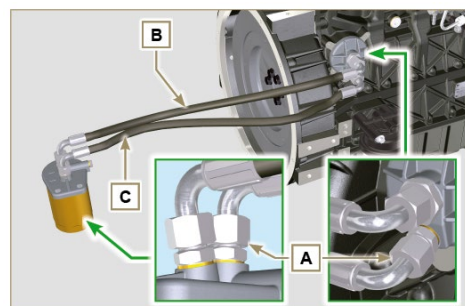


Fig 11.48

lose together with the nuts A, with the consequent of oil leakage.

2. Undo the nuts A and remove the hoses **B** and **C**.

3. Unscrew and remove the fitting **H** with its copper gasket from the head **J**.
4. Unscrew the fittings **K** and remove the copper gaskets from the head **J**.

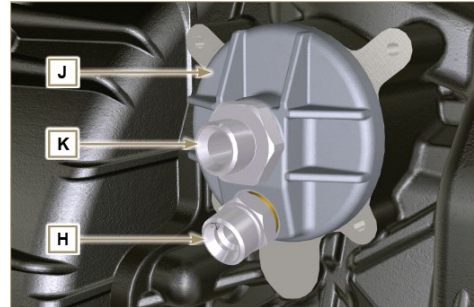


Fig 11.49

5. Unscrew the fittings **L** and remove the copper gaskets from the support **M**.
6. Unscrew the cartridge **N** with gasket from the support **M**.

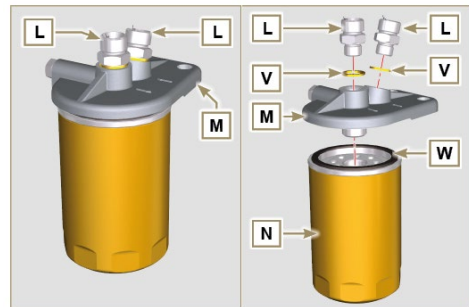


Fig 11.50

11.11.2 Assembly



Important

- Always replace the gaskets **V** after each assembly.
1. Clamp the fittings **H** on the support **M** inserting the gasket **V** (tightening torque at **65 Nm**).
 2. Lubricate the gasket **W** and clamp the cartridge **N** on the support **M** (tightening torque at **20 Nm**).

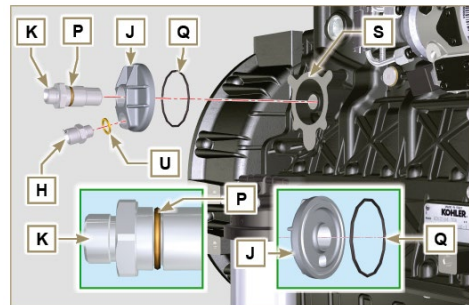


Fig 11.51



Important

- Always replace the gaskets **P**, **Q**, and **U** at each assembly.
 - Lubricate the gaskets **P**, **Q** with oil before assembling them.
3. Insert the gasket **P** on the seat of the fitting **K**.
 4. Insert the head **J** on the fitting **K** and the gasket **Q** in the seat of the head **J**.

5. Clamp the fitting **K** (tightening torque at **45 Nm + Loctite 2701**).
6. Clamp the fitting **H** on the flange **J** inserting the gasket **U** (tightening torque at **65 Nm**).
7. Connect the hose **B** to the central fitting of support **M** and of flange **J**.
8. Connect the hose **C** to the side fitting of the support **M** and of head **J**.
9. Clamp the nuts **A** on the head **J** (tightening torque at **48 Nm**).
10. Clamp the nuts **A** on the support **M** (tightening torque at **48 Nm**).

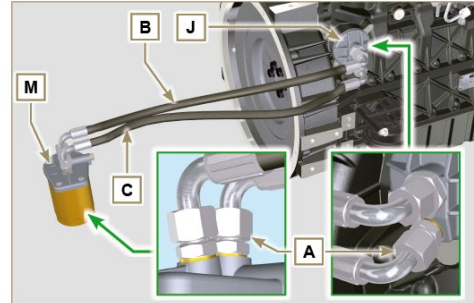


Fig 11.52



Important

- Check the tightening of the fittings **H** (Fig. 11.51) and **L** (Fig. 11.52) (tightening torque at **65 Nm**).

11.12 Intake circuit (replacement)



Important

- Before proceeding with operation, read [Par. 3.3.2](#).

11.12.1 Air filter disassembly

1. Release the clamp **B**.
2. Untighten the screws **A** and remove the filter **C**.

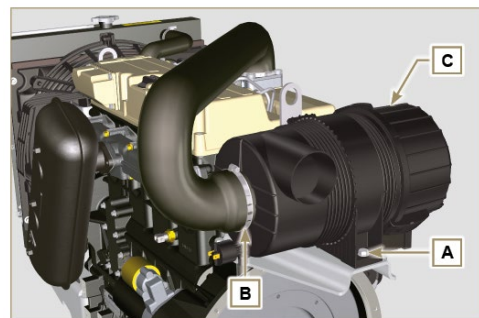


Fig. 11.53

11.12.2 Manifold air filter disassembly

1. Release the clamp **D**.
2. Remove the manifold **E**.
3. Loosen capscrews **G** and remove plate **H**.

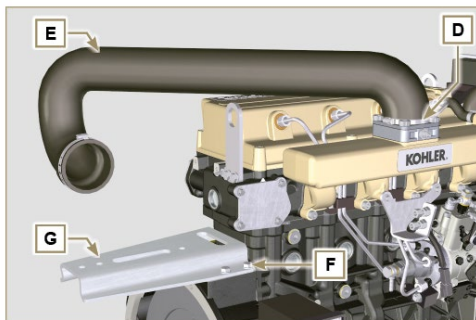


Fig. 11.54

11.12.3 Air filter manifold assembly

1. Insert the fitting **G** on the flange **H**.
2. Tighten the clamps **D**.
3. Fasten plate **G** by means of capscrews **F** (tightening torque at **25 Nm**).

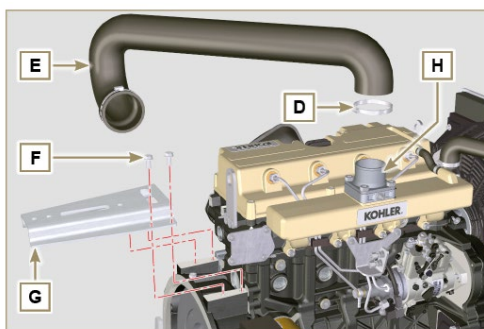


Fig. 11.55

11.12.4 Air filter assembly

1. Insert the filter **C** into the manifold **E**.
2. Tighten the clamps **B**.
3. Tighten the screws **A** (tightening torque at **25 Nm**)

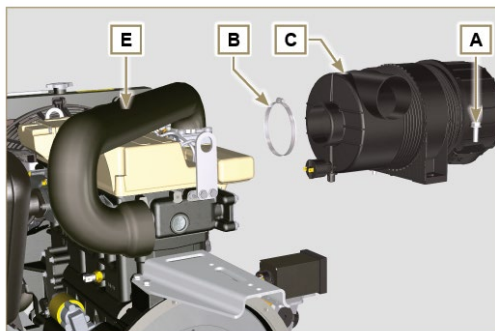


Fig. 11.56

11.13 Muffler (replacement)



Important

- Before proceeding with operation, read [Par. 3.3.2](#).

11.13.1 Disassembly

1. Undo the screw **A**.
2. Undo the nuts **B**.
3. Remove the muffler **C**.

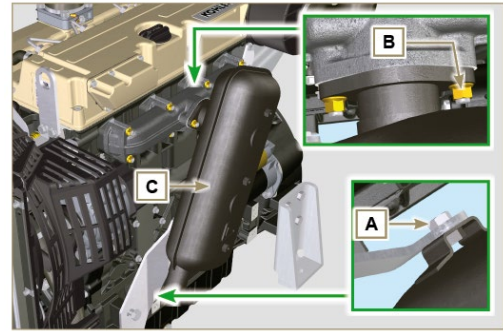


Fig. 11.57

11.13.2 Assembly

1. Position the gasket **D** and the muffler **C** on the intake manifold **E**.
2. Position the muffler **C** on the bracket **F** and tighten the screws **A** (tightening torque at **25 Nm**).
3. Tighten the nuts **B** (tightening torque at **25 Nm**).

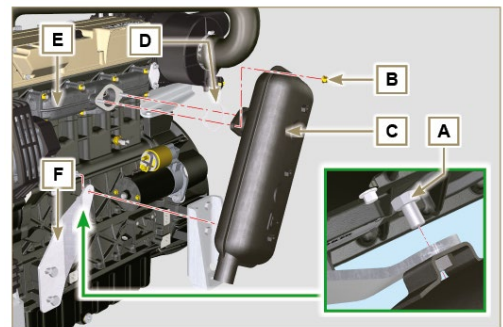


Fig. 11.58

11.14 Cooling circuit (replacement)



Important

- Before proceeding with operation, read [Par. 3.3.2](#).

11.14.1 Radiator disassembly

1. Release the clamp **A**.
2. Remove the sleeve **B**.

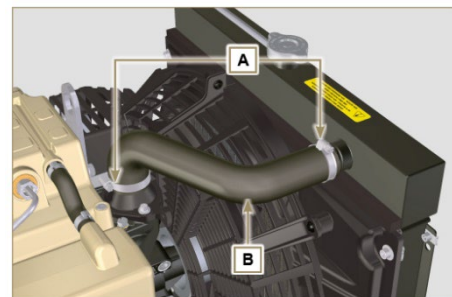


Fig. 11.59

3. Loosen the 4 capscrews **C** and capscrew **E**.

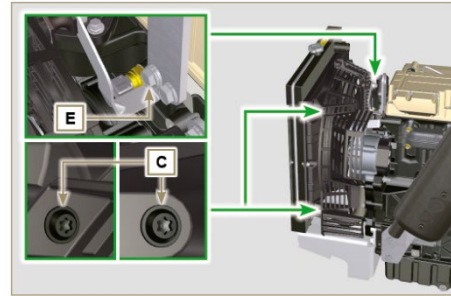


Fig. 11.60

4. Remove guard **D**.

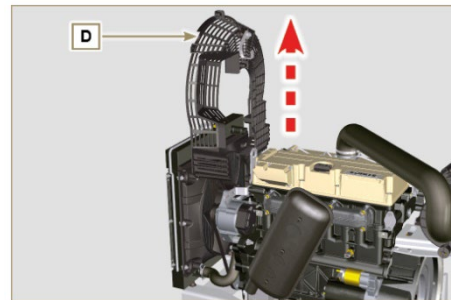


Fig. 11.61

5. Release the clamp **H**.
6. Release the pipe **L** from the radiator **M**.

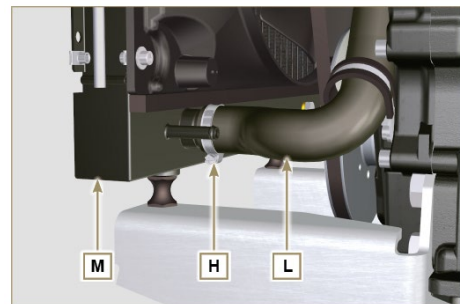


Fig. 11.62

7. Undo nuts **N** and remove the radiator **M**.

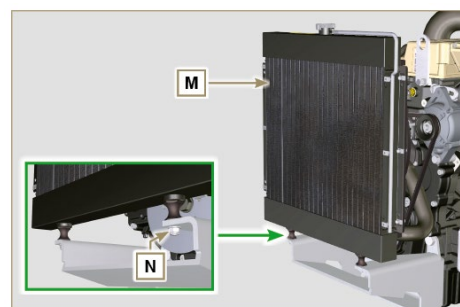


Fig. 11.63

11.14.2 Fan disassembly

1. Undo the screws **P** and remove the plate **Q** from the fan **R**.

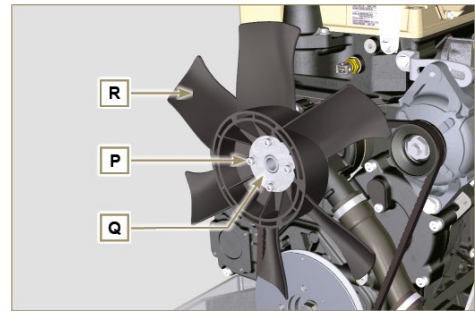


Fig. 11.64

11.14.3 Fan assembly

1. Assemble the fan **R** on the pulley **U**.
2. Position the plate **Q** on the fan **R**.
3. Fasten the fan **R** by using the screws **P** and interposin washers **S** (tightening torque at **10 Nm**).

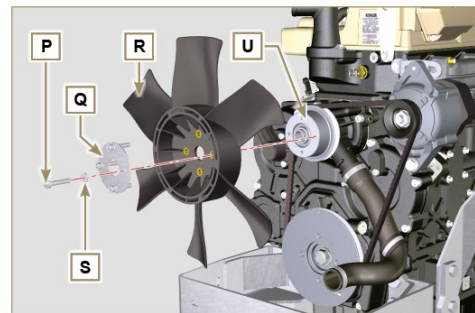


Fig. 11.65

11.14.4 Radiator assembly

1. Position the radiator on the support **V**.
2. Fasten radiator **M** on support **V** by means of nut **N** inserting washer **W** (tightening torque at **20 Nm**).

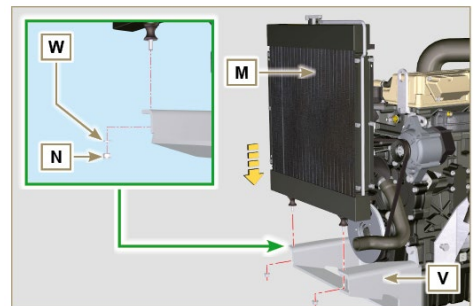


Fig. 11.66

3. Fit the sleeve **L** on the fitting of the radiator **M**.
4. Tighten the clamp **H**.

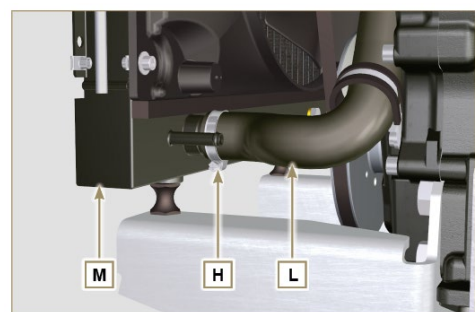


Fig. 11.67

5. Position bulkhead **D** onto shroud **F**.

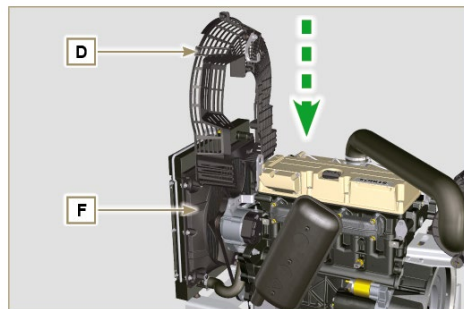


Fig. 11.68

6. Fasten brace **G** by means of capscrews **E** (tightening torque at **25 Nm**).
7. Fasten guard **D** by means of capscrews **C** (tightening torque **10 Nm**).

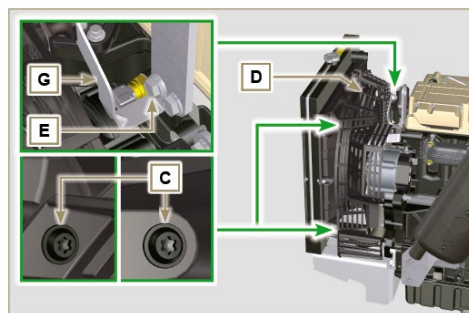


Fig. 11.69

8. Fit the sleeve **B** on the fitting of the radiator **M** and of the thermostat cover **Y**.
9. Tighten the clamps **A**.

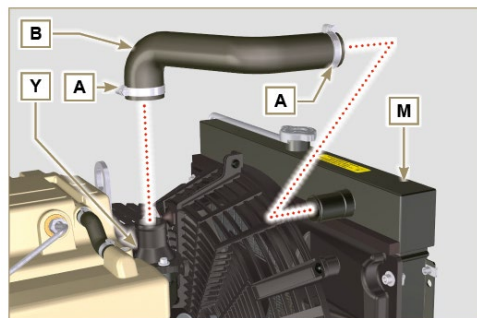


Fig. 11.70

11.15 Engine feet (information)

NOTE: Component not necessarily supplied by **KOHLER**. The representation of the engine is purely indicative.



Important

- The motor supports **A** can be installed on the bell **B** or on the crankcase **C** by using the screws **D** (tightening torque at **50 Nm**).

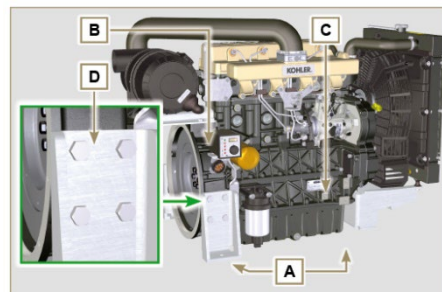


Fig. 11.71

11.16 Oil sump with supporting structure

11.16.1 Flywheel (J) disassembly

1. Execute the operations described in [Par. 7.10.1](#).

11.16.2 Plate/flange housing (L) disassembly

1. Loosen supplementary capscrews **A** and **B**.
2. Execute the operations described in [Par. 7.10.2](#).
3. Remove housing or plate **L**.

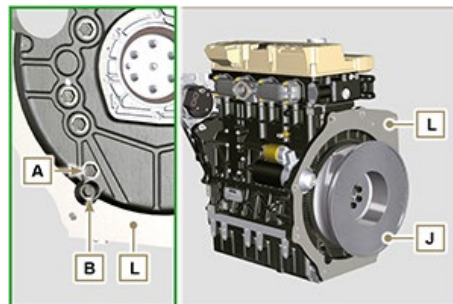


Fig. 11.72

11.16.3 Oil sump disassembly

1. Execute the operations described in [Par. 5.2](#).
2. Loosen capscrews **C** and remove bypass tube **D**.
3. Loosen capscrews **E** and remove oil sump **F**.

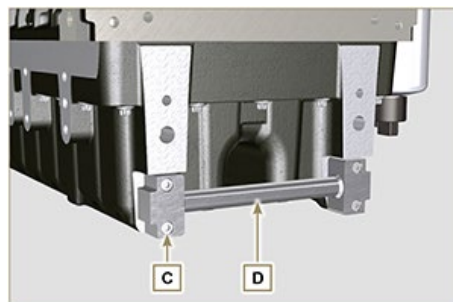


Fig. 11.73

11.16.4 Oil sump assembly

1. Make sure contact surfaces **G** of oil sump **F** and crankcase **H** have no impurities.
2. Apply a sealing bead of approximately **2.5 mm (Loctite 5660)** onto surface **G** of crankcase **H**.
3. Place oil sump **F** onto crankcase **H** in correspondence with the fastening holes (use tool [ST_18](#)).

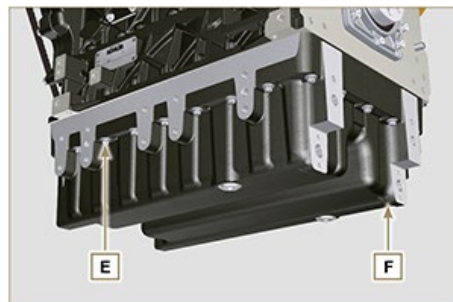


Fig. 11.74

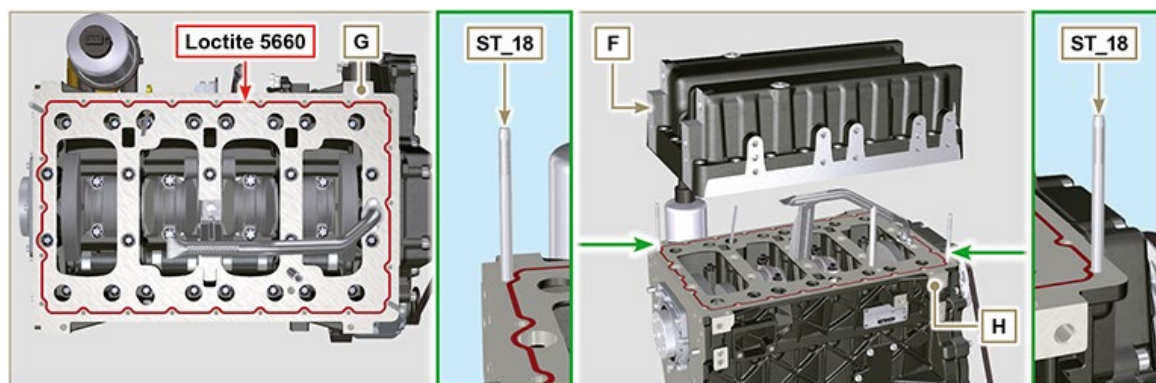


Fig. 11.75

4. Apply capscrews **E** into the fastening holes and use torque at **10 Nm**.
5. Loosen capscrews **E**, leaving approximately 1 mm leeway (**position A**) between the neck surface of capscrews **E** and oil sump **F**.
6. Place flange housing or plate **L** onto crankcase **H**, complying with centring tap pins **M**.
7. Using 2 capscrews **A**, fasten housing or plate **L** onto crankcase **H** (tightening torque at **20 Nm**).
8. Using 2 capscrews **A**, fasten housing or plate **L** onto oil sump **F** (tightening torque at **20 Nm**).

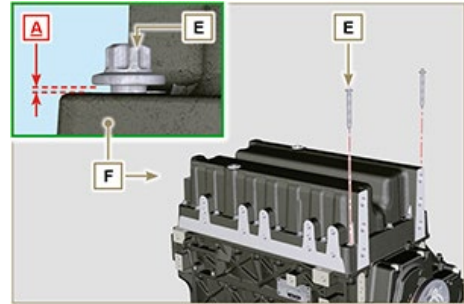


Fig. 11.76

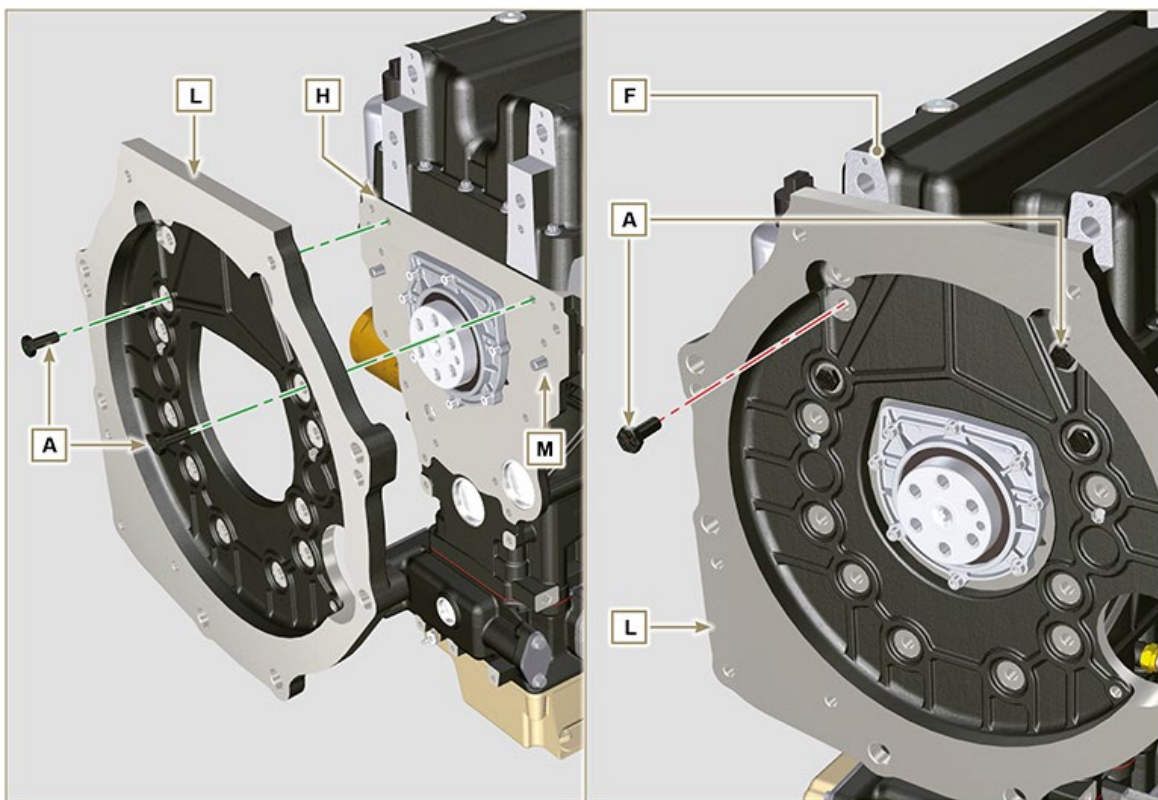


Fig. 11.77

9. Fasten oil sump **F** by tightening capscrews **E** and strictly following the order shown in **Fig. 11.77** (tightening torque at **20 Nm**).
10. Loosen capscrews **A** and remove housing or plate **L** (**Fig. 11.76**).
11. Fasten oil sump **F** by tightening capscrews **E** and strictly following the order shown in **Fig. 11.77** (tightening torque at **47 Nm**).
Loosen the screw **1** again and tighten it to **47 Nm**.

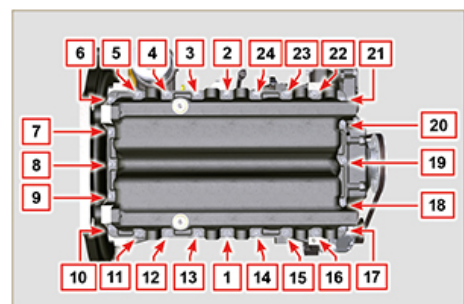


Fig. 11.78

12. Insert gaskets **N** into seats **P** of bypass tube **D**.
13. Fasten bypass tube **D** onto oil sump **F** using capscrews **C** (tightening torque at **10 Nm**).

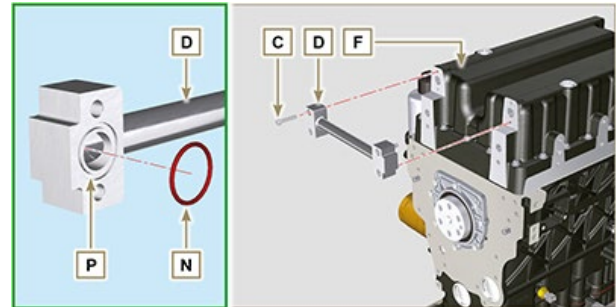


Fig. 11.79

11.16.5 Flange plate / housing assembly

1. Execute the operations described in **point 6** of **Par. 11.14.4**.
2. Fasten housing or plate **L** by using capscrews **A** and strictly following the order shown in **Fig. 11.79** (tightening torque at **85 Nm**).
3. Fasten housing or plate **L** by using capscrews **B** (tightening torque at **270 Nm**).

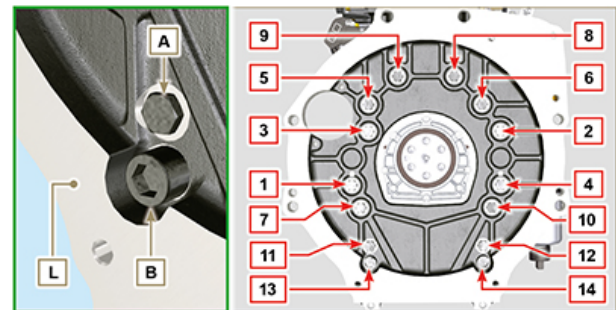


Fig. 11.80

11.16.6 Flywheel assembly

1. Execute the operations described in [Par. 9.5.2](#).

11.17 Oil sump 15L

11.17.1 Disassembly

1. Perform the operations indicated in [Par. 5.2](#).
2. Loosen the screws **A** and remove the oil sump **B**.
3. Loosen the screws **A1** and remove the oil sump **B1** flange.

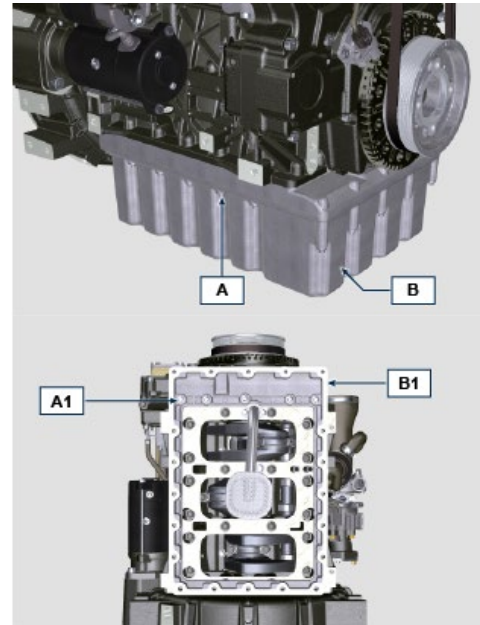


Fig. 11.81

11.17.2 Assembly

1. Apply a bead of approx. **2.5 mm** of sealant (**Loctite 5660**) inside the channel **B2** of the oil sump **B1** flange.
2. Position the oil sump **B1** on the crankcase **H** at the fixing holes (use the tool **ST_18**).
3. Screw the screws **A1** in the fixing holes.

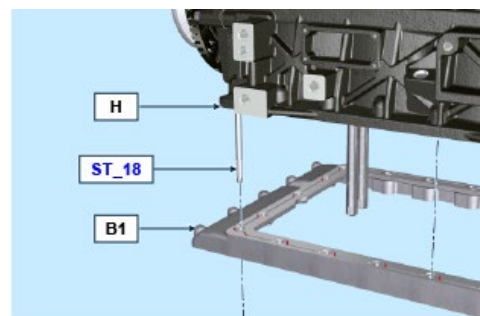
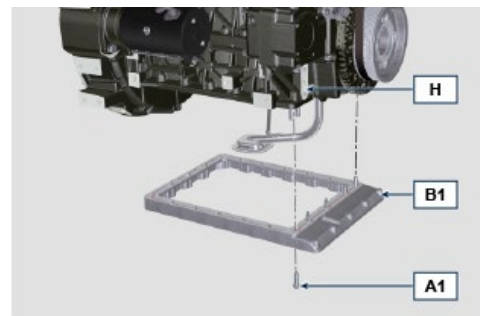
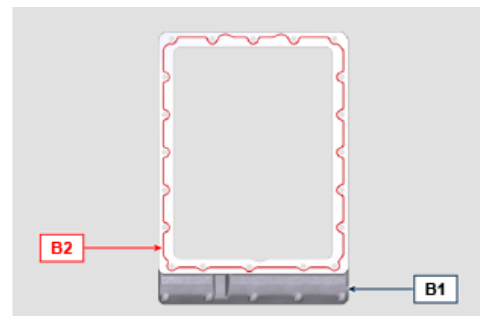
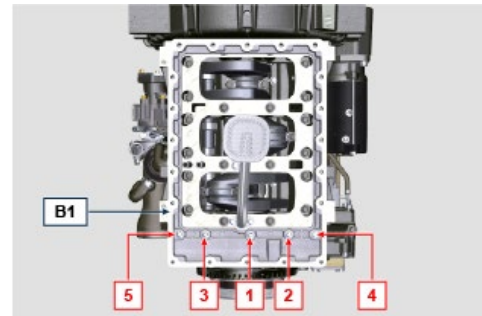
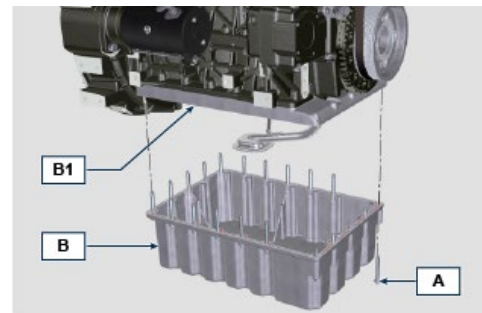
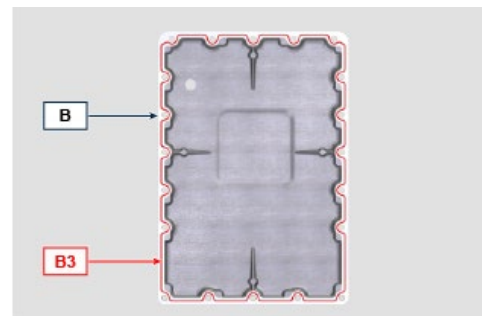


Fig. 11.82

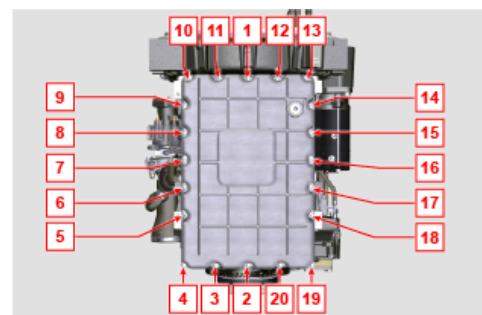
4. To fix the sump **B1** , tighten the screws **A1** by strictly following the order indicated in the **Fig. 11.83** (tightening torque of **25 Nm**).
5. Loosen the screw **1** again and tighten it to **25 Nm** .


Fig. 11.83

6. Apply a bead of approx. **2.5 mm** of sealant (**Loctite 5660**) inside the channel **B3** of the oil sump **B** .
7. Position the oil sump **B** on the oil sump **B1** flange at the fixing holes (use the tool **ST_18**).
8. Screw the screws **A** in the fixing holes.


Fig. 11.84

9. To fix the sump **B** , tighten the screws **A** by strictly following the order indicated in the **Fig. 11.85** (tightening torque of **25 Nm**).
10. Loosen the screw **1** again and tighten it to **25 Nm** .


Fig. 11.85

5. Fix the oil pressure switch **B** to the support **E** placing the gasket **B1** in-between (tightening torque of **25 Nm**).

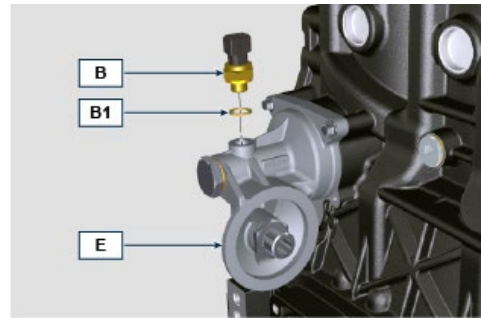


Fig 11.89

6. Lubricate the gasket of the cartridge **A** and secure the cartridge **A** to the support **E** (tightening torque of **20 Nm**).

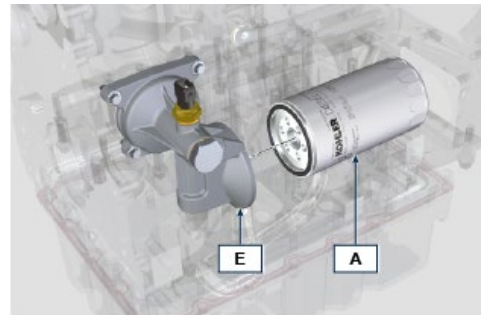


Fig 11.90

12 INFORMATION ON ADJUSTMENTS

12.1 Air filter check



Important

- Before proceeding with operation, read **Par. 3.3.2**.

1. Hose **A** must be completely clean and not damaged.
2. Air filter cartridge **B** and its housing **C** must be completely clean and free from impurities.

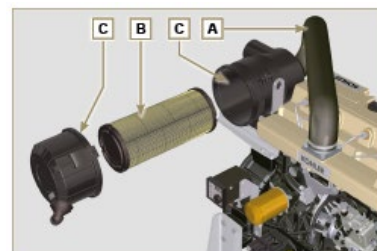


Fig 12.1

12.2 Rubber hose and manifold control



Important

- Before proceeding with operation, read **Par. 3.3.2**.

The check is carried out by applying slight deflection or bending along the tube/hose and next to the hose clamps.

Components must be replaced if they have clear signs of cracks, tears, cuts, leaks, or do not retain a certain degree of elasticity.

1. Check the condition of all rubber hoses **A**.
2. Check whether there are any leakages of air, water, oil or fuel next to their connections.

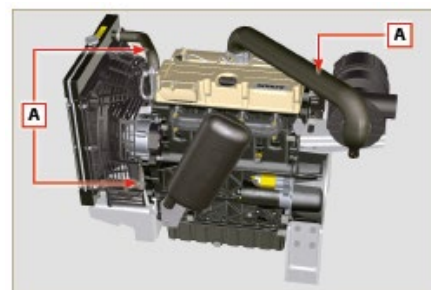


Fig 12.2

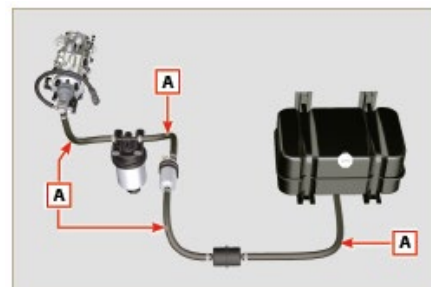


Fig 12.3

12.3 Oil leak check



Important

- Before proceeding with operation, read **Par. 3.3.2**.

Check that there are no leakages next to area **A**.

1. Start the engine at idle speed or without a load and check whether there are any leakages next to area **A**.
2. It is anyhow necessary to also check the seals of all main components and their surface contact, such as:
 - crankcase and oil seal (side 1^a PTO)
 - oil sump and exhaust caps
 - cylinder head and its assembled components
 - rocker arm cover
 - Timing system carter and oil seal (side 2^a PTO)
 - oil dipstick housing or rod support tube.

NOTE: Perform the checks described in **Points 1 and 2** periodically and during maintenance procedures. It is also necessary to check for leakages on the components that are not listed.

If necessary, disassemble the components that have a leakage and investigate the possible cause.

The components must be replaced otherwise they do not guarantee their sealing.

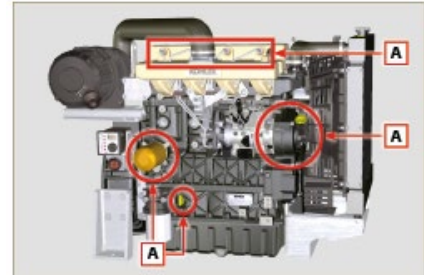


Fig 12.4

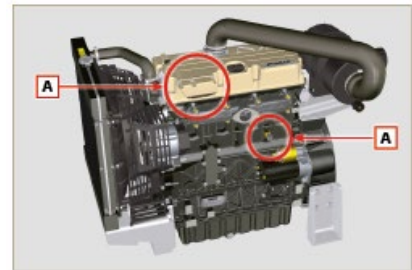


Fig 12.5

12.4 Oil pressure check

1. Insert a thermocouple instead of the oil dipstick **A**.
2. Unscrew and remove the oil pressure switch **B** and screw on a 10 bar pressure gauge in its seat (**Fig. 12.8**).
3. Start the engine at idle speed and without a load, check the oil pressure value according to the oil temperature (**Fig. 12.7**).

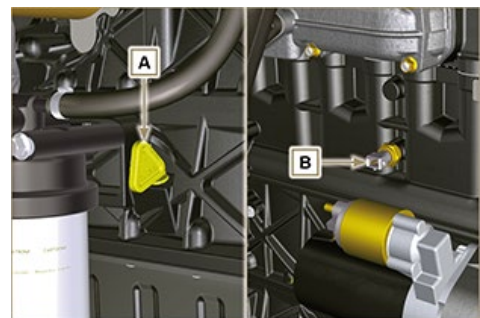


Fig. 12.6

NOTE: The graph in **Fig. 12.7** illustrates the pressure line with speed of 1000 Rpm.

4. If the pressure values are below the values indicated in **Fig. 12.7**, check to identify the cause of the problem.

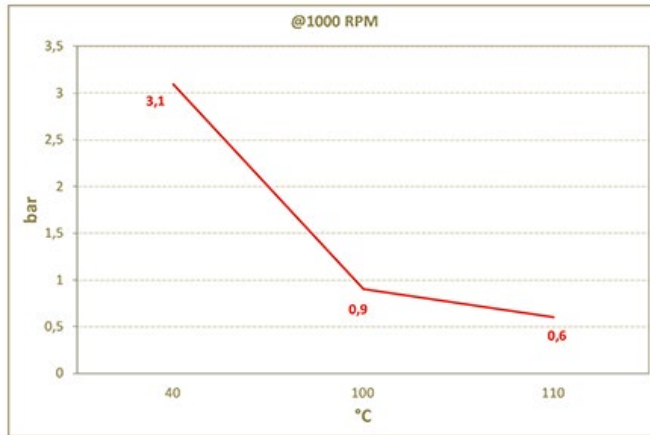


Fig. 12.7

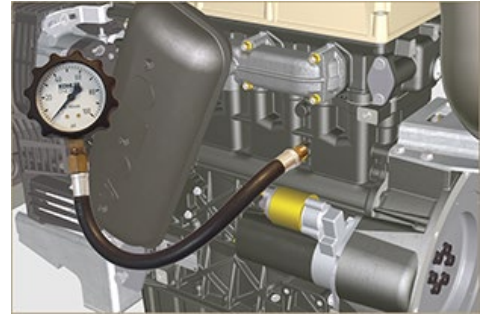


Fig. 12.8

13 TOOLS INFORMATION

13.1 Information regarding specific tools

In **Tab 13.1 - 13.2** there is a list of all the specific tools that are required and approved to carry out operations of disassembly - assembly - regulations - settings - repairs on engine series **KDI**, correctly and safely.



Warning

- **KOHLER** declines all responsibility for any damage to the engine, persons, or things caused by the use of different types of tools to those indicated in **Tab 13.1 - 13.2**, where referred to them in the manual.

Tab. 13.1


SPECIAL TOOLS FOR DISASSEMBLY AND ASSEMBLY

"ST"	Picture/Draw	DESCRIPTION	PART NUMBER
ST_03		Piston protrusion - injectors cylinder head surface control tool	ED0014602980-S
ST_04		High-pressure fuel injection pump puller gear	ED0014603680-S
ST_05		Spanner for capscrews Six nicks SN 8	ED0014603650-S
ST_06		Spanner for capscrews Six nicks SN 5	ED0014603640-S
ST_07		Tool for disassembling / reassembling valves	ED0014603720-S
ST_08		Tool for gasket valve stem	ED0014603660-S

ST_09		Tool for flywheel assembling / disassembling	ED0014603610-S
ST_10		Crankshaft gasket assembling tool	ED0014603670-S
ST_14		Buffer insertion of a crankshaft gasket onto a timing system carter	ED0014603750-S
ST_15		Locking screw balance shafts	ED0097301980-S
ST_17		Rocker arm cover mounting studs	ED0014603730-S
ST_18		Intake and oil sump manifold mounting studs	ED0014603740-S
ST_30		Piston n°1 tool positioning prior to injection pump assembly.	ED0014603940-S
ST_34		Crankshaft blocking tool	ED0014604270-S
ST_36		Assembling tool for a gasket on a rocker arm cover (injector seat)	ED0014603830-S
ST_51		Injectors placing tool	ED0014604310-S

Tab. 13.2

SPECIFIC EQUIPMENT TO PROTECT COMPONENTS OF THE INJECTION CIRCUIT

ST_40		Complete box with caps to close holes and unions for high-pressure injection circuit components.	ED0082051380-S
-------	---	--	----------------

14 INFORMATION ABOUT FAILURES

14.1 Possible causes and trouble shooting

IMMEDIATELY STOP THE ENGINE WHEN:

1. Engine rpm increases and decreases suddenly without being able to control them;
2. A sudden and unusual noise is heard;
3. The colour of the exhaust fumes suddenly darkens or turns white;
4. The oil pressure warning light or a Warning Lamp turns on during operation;
5. The coolant temperature warning light turns on during operation.

Tab. 14.1 contains the possible causes of some failures, which may occur during operation.

Always perform these simple checks before removing or replacing any part.



Warning

- Search for a topic and the operations to carry out from the analytical index or chapter index found at the beginning of the manual.
- Do not carry out any checks or operations on the engine when it is running.

Tab. 14.1

POSSIBLE CAUSE		TROUBLES													
		Engine does not start	Engine starts but stops	No acceleration	Variable speed	Black smoke	White smoke	Low oil pressure	Oil level increase	Excessive oil consumption	Oil and fuel drip from the exhaust	Engine overheats	Inadequate performance	High noise level	The Warning Lamp switches on
FUEL CIRCUIT	Clogged fuel hoses														
	Fuel filter clogged														
	Air or water in the fuel supply circuit														
	The tank cap vent hole is clogged														
	Faulty fuel feeding pump														
	No fuel														
ELECTRIC SYSTEM	Cable connection uncertain or incorrect														
	Faulty starting motor														
	Heater (optional)														
MAINTENANCE	Clogged air filter														
	Excessive idle operation														
	Incomplete run-in														

POSSIBLE CAUSE		TROUBLES													
		Engine does not start	Engine starts but stops	No acceleration	Variable speed	Black smoke	White smoke	Low oil pressure	Oil level increase	Excessive oil consumption	Oil and fuel drip from the exhaust	Engine overheats	Inadequate performance	High noise level	The Warning Lamp switches on
SETTINGS REPAIRS	Rings worn or sticking														
	Worn cylinder														
	Worn out valve guides														
	Badly sealed intake valve														
	Crankshaft/Connecting rod bearings worn out														
	Damaged cylinder head gasket														
	Defective timing system														
LUBRICATION CIRCUIT	Oil level too high														
	Oil level low														
	Dirty or blocked pressure regulating valve														
	Worn oil pump														
	Air in the oil suction pipe														
	Blocked draining pipe														
	Oil sump drainage pipe clogged														
INJECTION	Damaged injector														
	Damaged high-pressure pump														
	Wrong injector IMA codes														
COOLING CIRCUIT	Insufficient coolant														
	Defective fan, radiator, or radiator cap														
	Blockage inside the radiator or the coolant ducts														
	Heat exchange surface of the radiator clogged														
	Defective thermostatic valve														
	Coolant leaking from the radiator, manifolds, crankcase or from the water pump														
	Defective or worn water pump														

15 GLOSSARY

15.1 Glossary

A

Air gap:	Distance to respect between a fixed component and one in movement.
Alternator:	A component that transforms mechanical energy into AC electrical energy.
Authorised service station:	KOHLER authorised workshop.
Authorised workshop:	KOHLER authorised service centre.

B

Balancer device:	A device that reduces vibrations caused by movement of the alternating weights (Crankshaft - Connecting rods - Pistons).
Base configuration:	Engine having components represented in Para. 1.3 - 1.4 .
BDC:	Bottom Dead Centre; a moment in which the piston is at the start of its stroke.
Bore	Internal diameter of the cylinder in combustion engines.

C

Cold Start Advance:	The device provides for advance injection modification to enable advance of the engine at low temperatures.
Combustion:	Chemical reaction of a mixture composed of fuel and fuel (air) inside a combustion chamber.
Crankshaft:	A component that transforms straight operation into rotary operation, and vice-versa.

E

EC:	"European Community".
------------	-----------------------

F

Fig.: Figure.

Functional units: Component, or group of main components, able to carry out specific functions on the engine.

G

Galvanised: Material that has undergone surface protection treatment.

Grinding (valves and seats): Cleaning operation of the valves and seats carried out with an abrasive paste (refer to an authorised service station for this type of operation).

H

Heater: A device that heats the intake air by means of an electrical resistor.

Heavy conditions: Type of extreme condition referred to the work environment in which the engine is used (very dusty - dirty area, or in a contaminated environment due to various types of gas).

I

Idle speed operation: Operation of a running engine with the vehicle stopped and on idle speed.

K

KDI: "Kohler Direct Injection"

M

Maintenance - periodic A group of maintenance actions that have the sole objective to control and replace elements on their expiry, without modifying or improving the functions carried out by the system, neither increasing the value nor improving performance.

MAX: Maximum.

Methyl ester: It is a mixture of products by means of a chemical conversion of oils and animal and/or vegetable fat, which is used to produce Biofuel.

Min.: Minutes.

MIN: Minimum.

Model: Model, engine identification plate, which indicates the engine's model.

N

N/C: Normally Closed, referred to switches (oil-pressure switch).

N/O: Normally Opened, referred to switches (Coolant temperature sensor)

P

Par.: Paragraph.

Paraffin.: Fatty and solid substance that may form inside the diesel.

Pipe cleaner: An instrument having a metal cylindrical body with bristles that jut outwards. It is similar to a brush and is used to clean areas that are not easily accessible manually (e.g. oil ducts inside an engine).

Power operation: Operation of the engine at high speeds.

PTO: Power Take Off - a point provided to take advantage of alternative operation transmission.

R

Ref.: Reference.

Rpm: Rounds per minute.

S

s/n: Serial number (engine identification name plate) indicating the engine identification series/chassis number.

Spec.: Specification, (engine identification name plate) indicating the engine version.

STD: (Standard), base configuration of a component, or a group of components.

T

Tab.: Table.

TDC: Top Dead Centre; a moment in which the piston is at the end of its stroke.

Thermostatic valve: A valve that adjusts the flow of coolant liquid; it is able to operate by means of temperature variation.

Torque: Force applied to an object that rotates on an idler shaft.

Trochoid: Rounded toothed profile (also known as "lobes").

U

Used oil: Oil altered by operation or time, which is no longer compliant for correct lubrication of the components.

W

Warning Lamp: A warning light (usually red) that indicates a serious anomaly during engine operation.

SYMBOLS AND UNITS OF MEASUREMENT			
SYMBOL	UNIT OF MEASUREMENT	DESCRIPTION	EXAMPLE
α	degree	Rotation/inclination angle	1°
cm ²	square centimetre	Area	1 cm ²
Ø	millimetre	Circumference	Ø 1 mm
Nm	newton-metre	Torque	1 Nm
mm	millimetre	Length	1 mm
µm	1/1000 of a millimetre (micron)		1 µm
H	hour	Time	1 h
g/kW	grammes per kilowatt per hour	Specific consumption	1 g/kWh
kg/h	kilogramme per hour	Max. flow rate	1 kg/h
Lt./min.	litres per minute	Flow rate	1 Lt./min.
Lt./h	litres per hour		1 Lt./h
ppm	parts per million	Percentage	1 ppm
N	newton	Force	1 N
A	Ampere	Intensity of electrical current	1 A
gr.	gramme	Weight	1 gr.
kg	kilogramme		1 kg
W	Watt	Power	1 W.
kW	kiloWatt		1 kW
pa	pascal	Pressure	1 pa
KPa	Kilopascal		1 KPa
bar	barometric pressure		1 bar
mbar (1/1000 bar)	barometric pressure		1 mbar
R	Resistance	Resistance to electrical current (referred to a component)	1 Ω
Ω	ohm	Resistance of electrical current	1 Ω
Rpm	revs per minute	Rotation of an axis	1 Rpm

Ra	average roughness expressed in microns	Roughness	1 Ra
°C	degree centigrade	Temperature	1°C
V	Volt	Electrical voltage	1 V
●	millimetre	Hex-head capscrew	●1 mm
cm ³	cubic centimetre	Volume	1 cm ³
Lt.	litre		1 Lt.

KOHLER®

IN POWER. SINCE 1920.

Lombardini s.r.l. is a part of Kohler Group. Lombardini has manufacturing facilities in Italy, Slovakia and India and sales subsidiaries in France, Germany, UK, Spain and Singapore. Kohler/Lombardini reserves the right to make modifications without prior notice.
www.lombardini.it

DEUTSCHLAND

Lombardini Motoren GmbH
Fritz-Klatte-Str. 6, Bürogebäude 2
D – 65933 Frankfurt
Hessen, DEUTSCHLAND
T. +49-(0)69-9508160
F. +49-(0)69-950816-30

EUROPE

Lombardini Srl
Via Cav. del lavoro
A. Lombardini n° 2
42124 Reggio Emilia, ITALY
T. +39-(0)522-389-1
F. +39-(0)522-389-503

UK

Lombardini U.K. Ltd
1, Rochester Barn - Eynsham Road
OX2 9NH
Oxford, UK
T. +44-(0)1865-863858
F. +44-(0)1865-861754

USA & CANADA

Kohler Co.
444 Highland Drive,
Kohler - Wisconsin (53044), US
T. +1 920 457 4441
F. +1 920 459 1570

ESPAÑA

Lombardini ESPAÑA, S.L.
P.I. Cova Solera 1-9
08191 - Rubí (Barcelona)
ESPAÑA
T. +34-(0)9358-62111
F. +34-(0)9369-71613

FRANCE

Lombardini France S.a.s.
47 Allée de Riottier,
69400 Limas, FRANCE
T. +33-(0)474-626500
F. +33-(0)474-623945

CHINA & ROAPAC

Kohler China INVESTMENT Co. Ltd
no.158, Jiang Chang San Road,
200436, Zhabe, Shanghai
CHINA
Tel: +86 400-0120-648
Fax: +86 21 61078904

