

Operation and maintenance manual

Engine

4045HF120

4045HSG20

4045HSG21

4045TF120

4045TF220

4045TSG20

6068HF120-153

6068HF120-183

6068HFG20-153

6068HFG20-183

6068HFG20-202

6068HSG22

6068TF220

JOHN DEERE

Supplied by

KOHLER®

33521042101_2_1

OMRG25204 - 17/09/2019

PowerTech™ 4.5 L and 6.8 L Non-Certified and Tier 1 Certified OEM Diesel Engines



OPERATOR'S MANUAL

PowerTech™ 4.5 L and 6.8 L Non-Certified and Tier 1 Certified OEM Diesel Engines

OMRG25204 ISSUE 17SEP19 (ENGLISH)

CALIFORNIA

Proposition 65 Warning

Diesel engine exhaust and some of its constituents are known to the State of California to cause cancer, birth defects, and other reproductive harm.

If this product contains a gasoline engine:

⚠ WARNING

The engine exhaust from this product contains chemicals known to the State of California to cause cancer, birth defects or other reproductive harm.

The State of California requires the above two warnings.

Additional Proposition 65 Warnings can be found in this manual.

John Deere Power Systems

Worldwide Edition
PRINTED IN U.S.A.



Introduction

OEM Engine and Drivetrain Warranty Registration

RG24614 —UN—21OCT13



Scan this code to register your OEM engine online. You can also visit us directly at JohnDeere.com/warranty.

Why registering your OEM engine or drivetrain product is a really smart idea:

- **Get faster service.** Registering your engine or drivetrain product gives us the information we need to meet your service needs promptly and completely.
- **Protect your investment.** You'll be kept up-to-date on engine or drivetrain product updates.
- **Extend your warranty.** You'll be given the option to extend your coverage before your standard warranty term expires.
- **Stay informed.** Be the first to know about new products and money-saving offers from John Deere.

You're Covered

When you buy a John Deere engine or drivetrain product you aren't just buying pistons and crankshafts and gear drives. You're buying the ability to get work done. Without downtime, without worries, and without hassles. And you're buying the assurance that if you do need help, a strong support network will be there — ready to step in.

Confidence. That's what John Deere engines, John Deere drivetrains, and John Deere Warranties are all about.

Long durations. Warranties designed to give you confidence in your engine or drivetrain product.

Worldwide support. Get service when and where you need it. John Deere has 4,000+ service locations worldwide.

Genuine John Deere parts and service. Authorized service outlets will use only new or remanufactured parts or components furnished by John Deere.

Warranty Duration

Equipment operators can't afford downtime or unexpected repairs. That's why we offer a 2-year/2,000-hour warranty, with unlimited hours in the first year, on our OEM industrial and marine engines. This warranty takes effect the date that the engine is delivered to the first retail purchaser. In addition, extended warranties are available under certain conditions. John Deere offers a variety of purchased warranties to extend the warranty period for your engine. You'll be given the option to extend your coverage before your standard warranty term expires. Be sure to register your engine or drivetrain product and take full advantage of the John Deere service and support network.

Obtaining Warranty Service

Warranty service must be requested through an authorized John Deere service outlet before the expiration of the warranty. Evidence of the engine's or drivetrain product's delivery date to the first retail purchaser must be presented when requesting warranty service. Authorized service outlets include:

- John Deere distributor
- John Deere OEM service dealer
- John Deere equipment dealer
- John Deere marine dealer

Worldwide Support Network

Visit JohnDeere.com/dealer to find the authorized engine or drivetrain service location nearest you. For complete warranty details visit JohnDeere.com/warrantystatements to view, download, or print the warranty statement for your engine or drivetrain product.

ZE59858,000025E -19-31MAY17-1/1

Foreword

This manual contains information to operate and service PowerTech 4.5 L & 6.8 L non-certified and Tier 1¹ emission certified OEM engines built at Dubuque Iowa (T0), Saran France (CD) and Torreon Mexico (PE) from 1996 on. These engines have mechanically-controlled fuel systems.

READ THIS MANUAL carefully to learn how to operate and service your engine correctly. Failure to do so could result in personal injury or equipment damage.

THIS MANUAL SHOULD BE CONSIDERED a permanent part of your engine and should remain with the engine when you sell it.

MEASUREMENTS IN THIS MANUAL are given in both metric and customary U.S. unit equivalents. Use only correct replacement parts and fasteners. Metric and inch fasteners may require a specific metric or inch wrench.

RIGHT-HAND AND LEFT-HAND sides are determined by standing at the drive or flywheel end (rear) of the engine and facing toward the front of the engine.

¹Emission certified for United States as EPA Tier 1 and European Union as Stage 1.

WRITE ENGINE SERIAL NUMBERS and option codes in the spaces indicated in the Record Keeping Section. Accurately record all the numbers. Your dealer also needs these numbers when you order parts. File the identification numbers in a secure place off the engine.

SETTING FUEL DELIVERY beyond published factory specifications or otherwise overpowering will result in loss of warranty protection for this engine.

CERTAIN ENGINE ACCESSORIES such as radiator, air cleaner, and instruments are optional equipment on John Deere OEM Engines. These accessories may be provided by the equipment manufacturer instead of John Deere. This operator's manual applies only to the engine and those options available through the John Deere distribution network.

NOTE: This operators manual covers only engines provided to OEM (Outside Equipment Manufacturers). For engines in Deere machines, refer to the machine operators manual.

OURGP11,0000004 -19-20AUG15-1/1

Engine Owner

John Deere Engine Owner:

It is important for you to register your new engine for factory warranty. Registering your engine will allow your Service Dealer to verify your warranty status should a repair be needed. The easiest way to register your engine is via the internet. To register your engine for warranty via the internet, please use the following URL:

<http://www.johndeere.com/enginewarranty> Your John Deere Engine Distributor or local John Deere Service Dealer will also be happy to provide this service. If you would like to view the John Deere Service Dealer network or locate your nearest Dealer, use the following URL:
<http://www.johndeere.com/dealer>

OURGP11,0000251 -19-24OCT11-1/1

Identification View — 4.5 L Engines

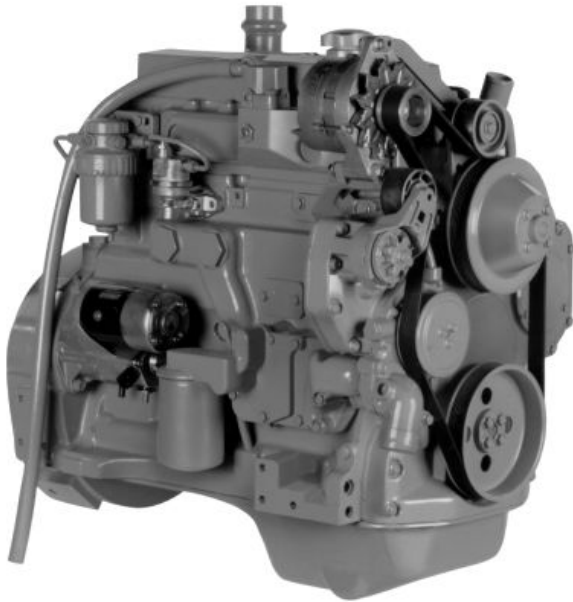

4045D Engine

RG7999 —UN—19JUN00

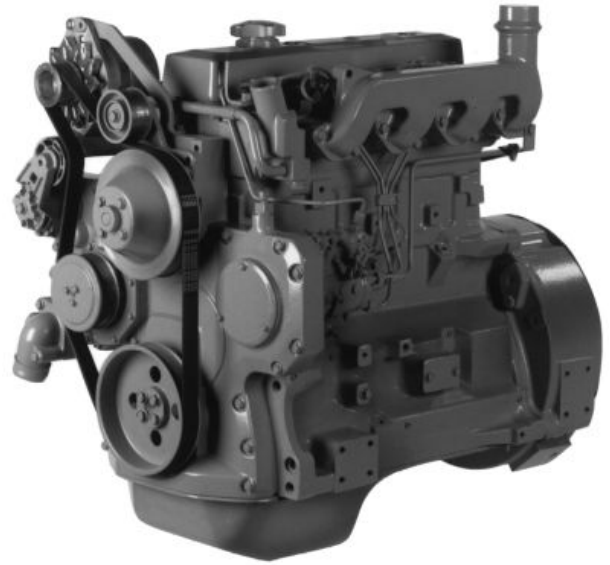

4045D Engine

RG7998 —UN—19JUN00

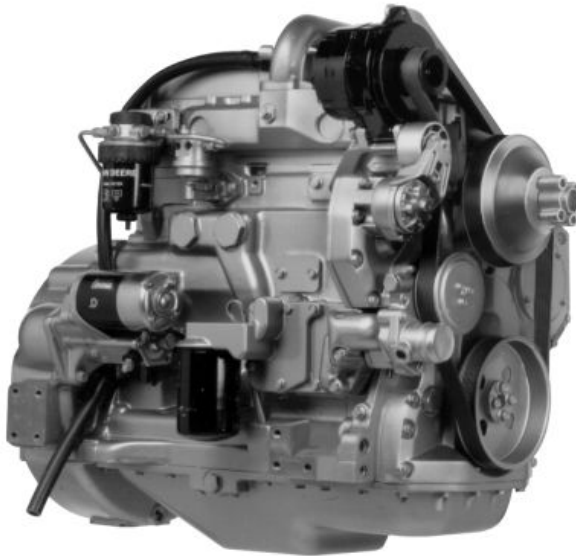

4045T Engine

RG7996 —UN—19JUN00



4045T Engine

RG7997 —UN—19JUN00

RG, RG34710, 5501 -19-20AUG15-1/1

Identification View — 6.8 L Engines



6068D Engine

RG8003 —UN—19JUN00

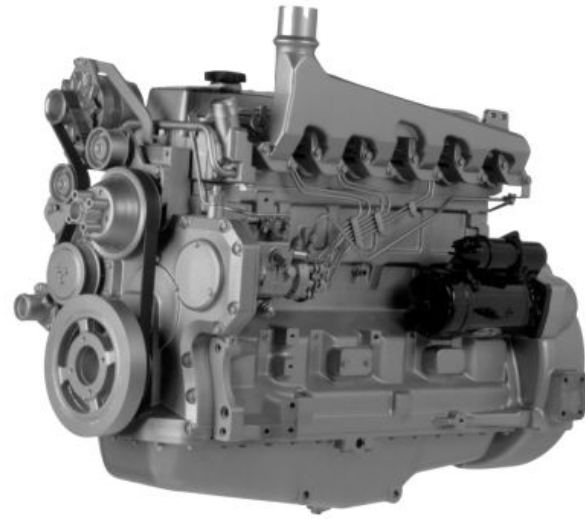

6068D Engine

RG8002 —UN—19JUN00



6068T Engine

RG8001 —UN—19JUN00

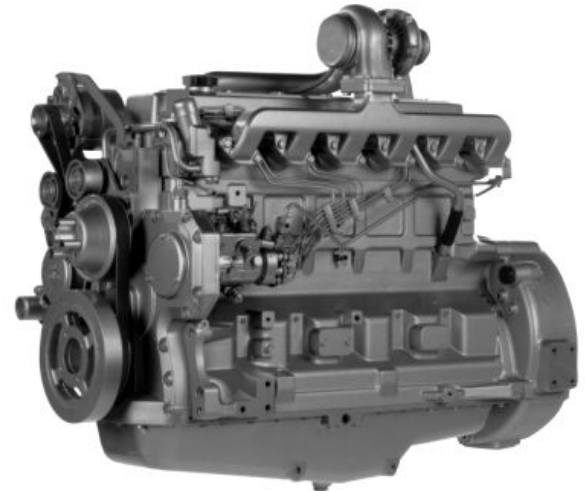

6068T Engine

RG8000 —UN—19JUN00

RG, RG34710, 5503 -19-20AUG15-1/1

Trademarks

Trademarks	
AdBlue®	AdBlue is a trademark of VDA, the German Association of the Automotive Industry.
AMP®	AMP is a trademark of Tyco Electronics
BIO-GREASE-GARD™	BIO-GREASE-GARD is a trademark of Deere & Company
Bio Hy-Gard™	Bio Hy-Gard is a trademark of Deere & Company
Bluetooth®	Bluetooth is a trademark of Bluetooth SIG
Break-In™ Plus	Break-In is a trademark of Deere & Company
CINCH™	CINCH is a trademark of Cinch Inc.
COOL-GARD™ PLUS	COOL-GARD is a trademark of Deere & Company
CoolScan™	CoolScan is a trademark of Deere & Company
COOLSCAN™ PLUS	COOLSCAN is a trademark of Deere & Company
Custom Performance™	Custom Performance is a trademark of Deere & Company
Deere™	Deere is a trademark of Deere & Company
DENSO®	DENSO is a trademark of DENSO Corporation
DEUTSCH®	DEUTSCH is a trademark of Deutsch Co.
DieselScan™	DieselScan is a trademark of Deere & Company
DuPont®	DuPont is a trademark of E.I. DuPont de Nemours and Company
EXTREME-GARD™	EXTREME-GARD is a trademark of Deere & Company
FleetGard™	FleetGard is a trademark of Deere & Company
Fuelscan™	Fuelscan is a trademark of Deere & Company
Funk™	Funk is a trademark of Deere & Company
GREASE-GARD™	GREASE-GARD is a trademark of Deere & Company
Hy-Gard™	Hy-Gard is a trademark of Deere & Company
JDLink™	JDLink is a trademark of Deere & Company
JDParts™	JDParts is a trademark of Deere & Company
JDPoint™	JDPoint is a trademark of Deere & Company
John Deere™	John Deere is a trademark of Deere & Company
Loctite®	Loctite is a trademark of Henkel Corporation
Metri-Pack®	Metri-Pack is a trademark of Delphi Connection Systems
OILSCAN PLUS™	OILSCAN PLUS is a trademark of Deere & Company
Oilscan™	Oilscan is a trademark of Deere & Company
Permatex®	Permatex is a trademark of Illinois Tool Works Inc.
Phoenix™	Phoenix is a trademark of Deere & Company
Plastigage®	Plastigage is a trademark of Perfect Circle Corporation
Plus-50™ II	Plus-50 is a trademark of Deere & Company
PowerSight™	PowerSight is a trademark of Deere & Company
PowerTech™	PowerTech is a trademark of Deere & Company
PowerTech™ E	PowerTech is a trademark of Deere & Company
PowerTech™ M	PowerTech is a trademark of Deere & Company
PowerTech™ Plus	PowerTech is a trademark of Deere & Company
Restore®	Restore is a trademark of "Restore, Inc."
Scotch-Brite®	Scotch-Brite is a trademark of 3M Co.
Scotch-Grip®	Scotch-Grip is a trademark of 3M Co.
Service ADVISOR™	Service ADVISOR is a trademark of Deere & Company
SERVICEGARD™	SERVICEGARD is a trademark of Deere & Company
SPEEDI-SLEEVE®	SPEEDI-SLEEVE is a registered trademark of the SKF Group.
SWEDA™	SWEDA is a trademark of Deere & Company
Swagelok®	Swagelok is a registered trademark of Swagelok Company.
TACH-N-TIME™	TACH-N-TIME is a trademark of Bosch Automotive Service Solutions Inc.
TeamMate™	TeamMate is a trademark of Deere & Company
TEFLON®	TEFLON is a trademark of Du Pont Co.

Continued on next page

ZE59858,0000006 -19-06AUG18-1/2

Introduction

Torq-Gard™	Torq-Gard is a trademark of Deere & Company
TORX®	TORX is a registered trademark of Acument Intellectual Properties, LLC
Vari-Cool™	Vari-Cool is a trademark of Deere & Company
WEATHER PACK®	WEATHER PACK is a trademark of Packard Electric
WINDOWS®	WINDOWS is a trademark of Microsoft Corporation

ZE59858,0000006 -19-06AUG18-2/2

Contents

	Page		Page
Record Keeping			
PowerTech Medallion	01-1	Lubricity of Diesel Fuel	10-2
Engine Serial Number Plate	01-1	Handling and Storing Diesel Fuel	10-2
Record Engine Serial Number	01-2	Biodiesel Fuel	10-3
Engine Option Codes	01-3	Testing Diesel Fuel	10-4
Record Fuel Injection Pump Model Number	01-4	Aviation (Jet) Fuels	10-4
		Burner Fuels	10-4
		Fuel Filters	10-5
Safety			
Recognize Safety Information	05-1	Minimizing the Effect of Cold Weather on Diesel Engines	10-6
Understand Signal Words	05-1	Diesel Engine Break-In Oil — Non-Emissions Certified and Certified Tier 1, Tier 2, Tier 3, Stage I, Stage II, and Stage III	10-7
Follow Safety Instructions	05-1	Diesel Engine Oil — Non-Emissions Certified and Certified Tier 1 and Stage I	10-8
Replace Safety Signs	05-2	Extended Diesel Engine Oil Service Intervals — Non-Emissions Certified and Certified Tier 1 and Stage I	10-9
California Proposition 65 Warning	05-2	Mixing of Lubricants	10-9
Illuminate Work Area Safely	05-2	Alternative and Synthetic Lubricants	10-9
Work in Clean Area	05-2	Lubricant Storage	10-10
Use Proper Tools	05-3	Oil Filters	10-10
Live With Safety	05-3	Diesel Engine Coolant (engine with wet sleeve cylinder liners)	10-11
Prevent Machine Runaway	05-3	Water Quality for Mixing with Coolant Concentrate	10-12
Handle Fuel Safely—Avoid Fires	05-4	Operating in Warm Temperature Climates	10-12
Prepare for Emergencies	05-4	Testing Coolant Freeze Point	10-13
Handle Starting Fluid Safely	05-4	Disposing of Coolant	10-13
In Case of Fire	05-5		
Handle Fluids Safely—Avoid Fires	05-5	Engine Operating Guidelines	
Avoid Static Electricity Risk When Refueling	05-6	Instrument (Gauge) Panels	15-1
Service Machines Safely	05-6	Instrument (Gauge) Panel (North America)	15-2
Wear Protective Clothing	05-6	VDO Instrument (Gauge) Panel (Except North America)	15-3
Protect Against Noise	05-7	Engine Break-In Service	15-4
Handling Batteries Safely	05-7	Auxiliary Gear Drive Limitations	15-6
Prevent Acid Burns	05-8	Generator Set (Standby) Applications	15-6
Stay Clear of Rotating Drivelines	05-8	Starting the Engine	15-6
Install All Guards	05-9	Warming Engine	15-8
Practice Safe Maintenance	05-9	Normal Engine Operation	15-8
Remove Paint Before Welding or Heating	05-10	Cold Weather Operation	15-9
Avoid Heating Near Pressurized Fluid Lines	05-10	Changing Engine Speed	15-10
Avoid High-Pressure Fluids	05-10	Avoid Excessive Engine Idling	15-10
Do Not Open High-Pressure Fuel System	05-11	Stopping the Engine	15-11
Protect Against High Pressure Spray	05-11		
Prevent Battery Explosions	05-11		
Avoid Hot Exhaust	05-12		
Work In Ventilated Area	05-12		
Service Cooling System Safely	05-12		
Decommissioning — Proper Recycling and Disposal of Fluids and Components	05-13		
Fuels, Lubricants, and Coolant			
Diesel Fuel	10-1		
Supplemental Diesel Fuel Additives	10-1		

Continued on next page

Original Instructions. All information, illustrations and specifications in this manual are based on the latest information available at the time of publication. The right is reserved to make changes at any time without notice.

COPYRIGHT © 2019
 DEERE & COMPANY
 Moline, Illinois
 All rights reserved.
 A John Deere ILLUSTRATION™ Manual
 Previous Editions
 Copyright © 1996, 2000, 2002, 2004, 2006, 2011, 2014, 2015, 2016, 2017, 2018

Page	Page		
Using a Booster Battery or Charger	15-12	Adding Coolant	45-2
Lubrication and Maintenance		Pre-Start Cleaning Guide	45-3
Required Emission-Related Information.....	20-1	Replacing Single Stage Air Cleaner	45-4
Observe Service Intervals	20-1	Replacing Axial Seal Air Cleaner Filter	
Use Correct Fuels, Lubricants, and Coolant.....	20-1	Element.....	45-5
Lubrication and Maintenance Service		Replacing Radial Seal Air Cleaner	
Interval Chart.....	20-2	Filter Element.....	45-6
Lubrication & Maintenance — Daily		Replacing Fan and Alternator Belts.....	45-7
Daily Prestarting Checks	25-1	Checking Fuses In Instrument Panels.....	45-8
Lubrication & Maintenance — 250 Hours/6		Checking Air Compressors.....	45-9
Months		Bleeding the Fuel System.....	45-9
Servicing Fire Extinguisher.....	30-1	Troubleshooting	
Changing Engine Oil and Replacing Filter.....	30-1	General Troubleshooting Information	50-1
Checking Engine Mounts.....	30-3	Engine Wiring Diagram Legend	
Servicing Battery	30-3	(Standard Instrument Panel For	
Manual Belt Tensioner Adjustment.....	30-5	North America).....	50-2
Manual Belt Tensioner Adjustment		Wiring Diagram (Standard Instrument	
Using Belt Tension Tool (Alternate		Panel For North America)	50-3
Method For Engines Without		Engine Wiring Diagram—VDO	
Auxiliary Drive).....	30-6	Instrument Panel (Except North America).....	50-4
Lubrication & Maintenance — 500 Hours/12		Engine Wiring Diagram Legend—VDO	
Months		Instrument Panel (Except North America).....	50-5
Cleaning Crankcase Vent Tube.....	35-1	Engine Troubleshooting.....	50-6
Checking Air Intake System	35-1	Storage	
Replacing Fuel Filter Element (Single Filter).....	35-2	Engine Storage Guidelines.....	55-1
Replacing Fuel Filter Elements (Dual Filters).....	35-3	Preparing Engine for Long-Term Storage.....	55-1
Checking Belt Tensioner Spring		Removing Engine from Long Term Storage	55-2
Tension and Belt Wear (Automatic		Specifications	
Tensioner)	35-4	General OEM Engine Specifications —	
Checking Engine Speeds	35-6	4.5 L Engines	60-1
Checking Engine Electrical Ground		General OEM Engine Specifications —	
Connections	35-6	6.8 L Engines	60-1
Checking Cooling System	35-6	Engine Power Ratings And Fuel	
Replenishing Supplemental Coolant		Injection Pump Specifications — 4.5	
Additives (SCAs) Between Coolant		L Engines	60-2
Changes.....	35-7	Engine Power Ratings And Fuel	
Testing Diesel Engine Coolant.....	35-8	Injection Pump Specifications — 6.8	
Pressure Testing Cooling System.....	35-9	L Engines	60-6
Lubrication & Maintenance — 2000 Hours/24		Engine Power Ratings And Fuel	
Months		Injection Pump Specifications	60-9
Adjusting Variable Speed (Droop) on		Engine Crankcase Oil Fill Quantities	60-16
Generator Set Engines.....	40-1	Unified Inch Bolt and Screw Torque Values.....	60-17
Checking Crankshaft Vibration Damper		Metric Bolt and Screw Torque Values.....	60-18
(6-Cylinder Engine Only).....	40-3	Lubrication and Maintenance Records	
Flushing and Refilling Cooling System	40-4	Using Lubrication and Maintenance Records.....	65-1
Testing Thermostats Opening Temperature	40-6	Daily (Prestarting) Service.....	65-1
Check and Adjust Valve Clearance	40-9	250 Hour/6 Month Service.....	65-1
Service as Required		500 Hour/12 Month Service.....	65-2
Additional Service Information.....	45-1	2000 Hour/24 Month Service.....	65-2
Do Not Modify Fuel System.....	45-1	Service as Required	65-3

Continued on next page

Page

Warranty

John Deere Warranty in OEM Applications 70-1

Emissions Control System Certification Label 70-4

EPA Non-road Emissions Control

 Warranty Statement—Compression Ignition .. 70-5

CARB Non-road Emissions Control

 Warranty Statement—Compression Ignition .. 70-7

John Deere Service Literature Available

Technical Information..... 75-1

Record Keeping

POWERTECH® Medallion

A medallion is located on the rocker arm cover which identifies each engine as a John Deere **POWERTECH®** engine.



RG11608—UN—17OCT01



RG11609—UN—17OCT01

POWERTECH is a trademark of Deere & Company.

RG, RG34710, 5505 -19-04JAN02-1/1

Engine Serial Number Plate

Each engine has a 13-digit John Deere engine serial number. The first two digits identify the factory that produced the engine:

- "T0" indicates the engine was built in Dubuque, Iowa
- "CD" indicates the engine was built in Saran, France
- "PE" indicates the engine was built in Torreón, Mexico
- "J0" indicates the engine was built in Rosario, Argentina

Your engine's serial number plate (A) is located on the right-hand side of cylinder block behind the fuel filter.

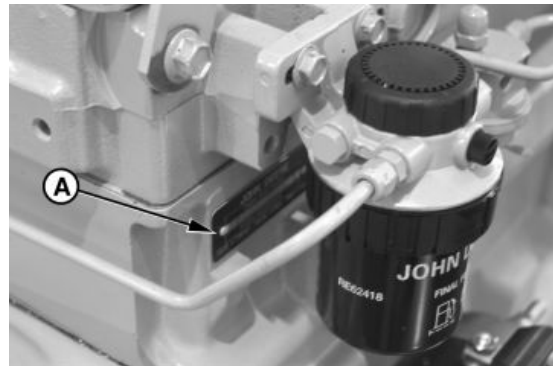

13-Digit Engine Serial Number Plate

RG8007—UN—15JAN99

RG, RG34710, 5506 -19-04JAN02-1/1

Record Engine Serial Number

Record all of the numbers and letters found on your engine serial number plate in the spaces provided below.

This information is very important for repair parts or warranty information.

Engine Serial Number (B)

Engine Model Number (C)

Coefficient of Absorption Value (D)
(Saran Engines Only)



Dubuque Engine Serial Number Plate

RG7936—UN—13NOV97



Saran Engine Serial Number Plate

RG7935—UN—13NOV97



Torreon Engine Serial Number Plate

RG9062—UN—16MAR98

RG, RG34710, 5507 -19-04JAN02-1/1

Engine Option Codes

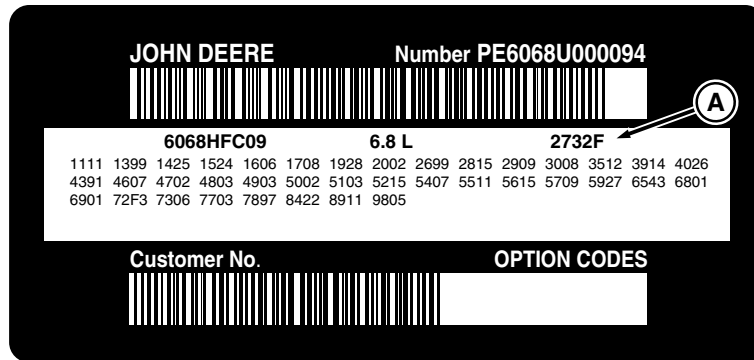

Option Code Label Example

A—Engine Base Code (example)

OEM engines have an engine option code label affixed to the rocker arm cover. These codes indicate which of the engine options were installed on your engine at the factory. When in need of parts or service, furnish your authorized servicing dealer or engine distributor with these numbers.

The engine option code label includes an engine base code (A). This base code must also be recorded along with the option codes. At times it will be necessary to furnish this base code to differentiate two identical option codes for the same engine model.

The first two digits of each code identify a specific group, such as alternators. The last two digits of each code identify one specific option provided on your engine, such as a 24 volt, 120 amp alternator.

If an engine is ordered without a particular component, the last two digits of that functional group option code will be 99, 00, or XX. The following list shows only the first two digits of the code numbers. For future reference such as ordering repair parts, it is important to have these code numbers available. To ensure this availability, enter the third and fourth digits shown on your engine option code label in the spaces provided on the following page.

Option Codes	Description
10_____	Paint Protection
11_____	Rocker Arm Cover
12_____	Oil Filler
13_____	Crankshaft Pulley
14_____	Flywheel Housing
15_____	Flywheel
16_____	Fuel Injection System
17_____	Air Inlet
18_____	Air Cleaner
19_____	Oil Pan
20_____	Water Pump
21_____	Thermostat Cover
22_____	Thermostat
23_____	Fan Drive
24_____	Fan Belt

An additional option code label may also be delivered (in a plastic bag attached to the engine or inserted in the machine documentation). It is recommended to place this label either on this page of the operators manual or in the Engine Owner's Warranty booklet under Option Codes.

The machine manufacturer may have placed the label in a specific accessible area (inside the enclosure or close to a maintenance area).

Your engine option code label may not contain all option codes if an option has been added after the engine left the producing factory.

If option code label is lost or destroyed, consult your servicing dealer or engine distributor selling the engine for a replacement.

Record your engine Base Code (A) in the spaces provided below for easy reference.

Engine Base Code (A):

Option Codes	Description
56_____	Paint
57_____	Water Pump Inlet
58_____	Power Take Off
59_____	Oil Cooler/Oil Filter
60_____	Add-On Fan Drive Pulley
61_____	After Treatment Device/Muffler
62_____	Alternator Mounting
63_____	Low-Pressure Fuel Lines
64_____	Exhaust Elbow
65_____	Turbocharger
66_____	Temperature Switch
67_____	Engine Sensors
68_____	Damper
69_____	Engine Serial Number Plate
70_____	Decomposition Tube (OEM)

Continued on next page

RG, RG34710, 5004 -19-12JUN17-1/2

RG24026—UN—05AUG13

Record Keeping

Option Codes	Description	Option Codes	Description
25_____	Fan	71_____	SCR (OEM)
26_____	Block Heater	72_____	Performance Software and Labels
27_____	Radiator/Heat Exchanger	7A_____	Performance Software and Labels
28_____	Exhaust Manifold	73_____	After Treatment Dosing System
29_____	Ventilator System	74_____	Air Conditioning
30_____	Starting Motor	75_____	Restriction Indicator
31_____	Alternator	76_____	Oil Pressure Switch
32_____	DEF Lines, Pressure (OEM)	77_____	Timing Gear Cover (S450/S650)
33_____	DEF Lines, Supply/Return to Tank (OEM)	78_____	Air Compressor
34_____	DEF Tank and Header (OEM)	79_____	Certification
35_____	Final Fuel Filter	80_____	Sea Water Pump (Marine)
36_____	Front Plate and Idler Shafts	81_____	Primary Fuel Filter/Water Separator
37_____	Fuel Transfer Pump	82_____	Ignition System (Natural Gas)
38_____	Operator Manual	83_____	Vehicle Performance Software
39_____	Thermostat Housing	84_____	Wiring Harness
40_____	Dipstick and Tube	85_____	Fuel System (Natural Gas)
41_____	Belt Driven Auxiliary Drive (Add-On Crank Pulley)	86_____	Fan Pulley
42_____	DEF Line, Supply Module to Injector (OEM)	87_____	Belt Tensioner
43_____	Starting Aid	88_____	Oil Filter
44_____	Timing Gear Cover (S350)	89_____	EGR System
44_____	Tachometer Drive Sensors (S450/S650)	90_____	Trim Software (OEM)
45_____	Secondary Balancers	91_____	Engine Installation Kit (S350)
46_____	Cylinder Block with Camshaft	92_____	Engine Test Certificate/Engine Accessories (S350)
47_____	Crankshaft/Main Bearings	92_____	Engine Installation Kit (S450)
48_____	Connecting Rods/Pistons/Liners	93_____	Emission Label
49_____	Valve Actuating Mechanism	94_____	Custom Software
50_____	Oil Pump	95_____	Parts Installed at Factory
51_____	Cylinder Head with Valves	96_____	Engine Installation Kit/Ship With (S450/S650)
52_____	Gear Driven Auxiliary Drive	96_____	ECU Wiring Harness (6125/6135)
53_____	Fuel Heater	97_____	Field Installed Items
54_____	Turbo Air Intake	98_____	Engine Lift Strap
55_____	Shipping Stand	99_____	Service Only Parts

NOTE: This is a complete option code list based on the latest information available at the time of publication. The right is reserved to make changes

at any time without notice. Your engine will not contain all option codes listed.

RG, RG34710,5004 -19-12JUN17-2/2

Record Fuel Injection Pump Model Number

Record the fuel injection pump model and serial information found on the serial number plate (A).

Model No. _____ RPM _____

Manufacturer's No. _____

Serial No. _____

A—Serial Number Plate

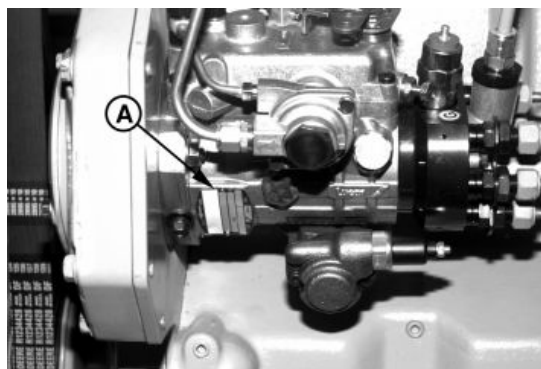

Record Injection Pump Serial Number

RG8008A—UN—13JUN00

RG, RG34710,5511 -19-20MAY96-1/1

Safety

Recognize Safety Information

This is a safety-alert symbol. When you see this symbol on your machine or in this manual, be alert to the potential for personal injury.

Follow recommended precautions and safe operating practices.

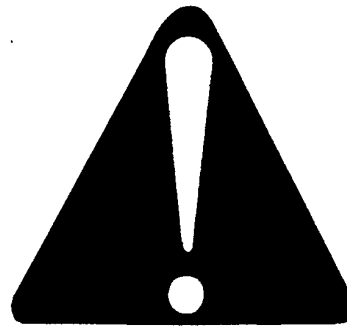

DX,ALERT -19-29SEP98-1/1

TS1389 —UN—28JUN13

Understand Signal Words

DANGER; The signal word DANGER indicates a hazardous situation which, if not avoided, will result in death or serious injury.

WARNING; The signal word WARNING indicates a hazardous situation which, if not avoided, could result in death or serious injury.

CAUTION; The signal word CAUTION indicates a hazardous situation which, if not avoided, could result in minor or moderate injury. CAUTION may also be used to alert against unsafe practices associated with events which could lead to personal injury.

A signal word—DANGER, WARNING, or CAUTION—is used with the safety-alert symbol. DANGER identifies the most serious hazards. DANGER or WARNING safety signs are located near specific hazards. General

precautions are listed on CAUTION safety signs. CAUTION also calls attention to safety messages in this manual.



DX,SIGNAL -19-05OCT16-1/1

TS187 —19—30SEP88

Follow Safety Instructions

Carefully read all safety messages in this manual and on your machine safety signs. Keep safety signs in good condition. Replace missing or damaged safety signs. Be sure new equipment components and repair parts include the current safety signs. Replacement safety signs are available from your John Deere dealer.

There can be additional safety information contained on parts and components sourced from suppliers that is not reproduced in this operator's manual.

Learn how to operate the machine and how to use controls properly. Do not let anyone operate without instruction.

Keep your machine in proper working condition. Unauthorized modifications to the machine may impair the function and/or safety and affect machine life.

If you do not understand any part of this manual and need assistance, contact your John Deere dealer.



DX,READ -19-16JUN09-1/1

TS201 —UN—15APR13

Replace Safety Signs

Replace missing or damaged safety signs. Use this operator's manual for correct safety sign placement.

There can be additional safety information contained on parts and components sourced from suppliers that is not reproduced in this operator's manual.



TS201—UN—15APR13

DX,SIGNS -19-18AUG09-1/1

California Proposition 65 Warning

Diesel engine exhaust, some of its constituents, along with certain machine components contain or emit chemicals known to the State of California to cause cancer and birth

defects or other reproductive harm. In addition, certain fluids contained in the machine and certain products of component wear contain or emit chemicals known to the State of California to cause cancer and birth defects or other reproductive harm.

RG41061,000001F -19-12JAN10-1/1

Illuminate Work Area Safely

Illuminate your work area adequately but safely. Use a portable safety light for working inside or under the machine. Make sure the bulb is enclosed by a wire cage. The hot filament of an accidentally broken bulb can ignite spilled fuel or oil.

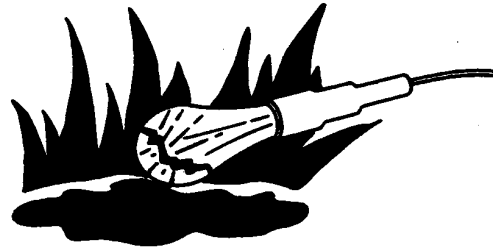

TS223—UN—23AUG88

DX,LIGHT -19-04JUN90-1/1

Work in Clean Area

Before starting a job:

- Clean work area and machine.
- Make sure you have all necessary tools to do your job.
- Have the right parts on hand.
- Read all instructions thoroughly; do not attempt shortcuts.

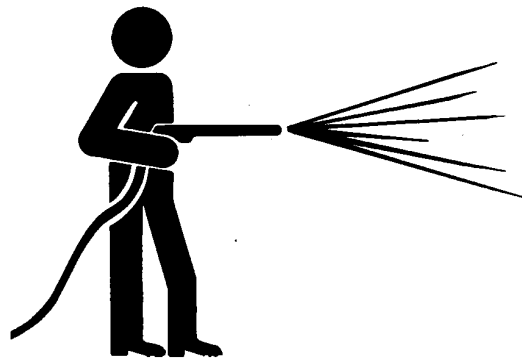

T6642EJ—UN—18OCT88

DX,CLEAN -19-04JUN90-1/1

Use Proper Tools

Use tools appropriate to the work. Makeshift tools and procedures can create safety hazards.

Use power tools only to loosen threaded parts and fasteners.

For loosening and tightening hardware, use the correct size tools. DO NOT use U.S. measurement tools on metric fasteners. Avoid bodily injury caused by slipping wrenches.

Use only service parts meeting John Deere specifications.



TS779 —UN—08NOV89

DX,REPAIR -19-17FEB99-1/1

Live With Safety

Before returning machine to customer, make sure machine is functioning properly, especially the safety systems. Install all guards and shields.



TS231 —19—07OCT88

DX,LIVE -19-25SEP92-1/1

Prevent Machine Runaway

Avoid possible injury or death from machinery runaway.

Do not start engine by shorting across starter terminals. Machine will start in gear if normal circuitry is bypassed.

NEVER start engine while standing on ground. Start engine only from operator's seat, with transmission in neutral or park.

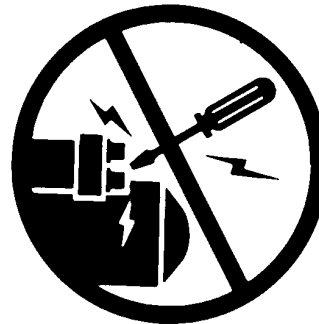

TS177 —UN—11JAN89

DX,BYPAS1 -19-29SEP98-1/1

Handle Fuel Safely—Avoid Fires

Handle fuel with care: it is highly flammable. Do not refuel the machine while smoking or when near open flame or sparks.

Always stop engine before refueling machine. Fill fuel tank outdoors.

Prevent fires by keeping machine clean of accumulated trash, grease, and debris. Always clean up spilled fuel.

Use only an approved fuel container for transporting flammable liquids.

Never fill fuel container in pickup truck with plastic bed liner. Always place fuel container on ground before refueling. Touch fuel container with fuel dispenser nozzle before removing can lid. Keep fuel dispenser nozzle in contact with fuel container inlet when filling.



TS202 —UN—23AUG88

Do not store fuel container where there is an open flame, spark, or pilot light such as within a water heater or other appliance.

DX,FIRE1 -19-12OCT11-1/1

Prepare for Emergencies

Be prepared if a fire starts.

Keep a first aid kit and fire extinguisher handy.

Keep emergency numbers for doctors, ambulance service, hospital, and fire department near your telephone.

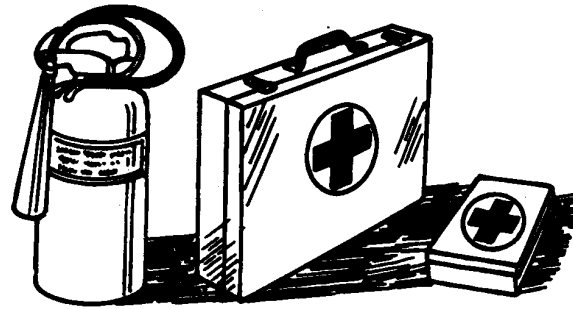

TS291 —UN—15APR13

DX,FIRE2 -19-03MAR93-1/1

Handle Starting Fluid Safely

Starting fluid is highly flammable.

Keep all sparks and flame away when using it. Keep starting fluid away from batteries and cables.

To prevent accidental discharge when storing the pressurized can, keep the cap on the container, and store in a cool, protected location.

Do not incinerate or puncture a starting fluid container.

Do not use starting fluid on an engine equipped with glow plugs or an air intake heater.



TS1366 —UN—18MAR92

DX,FIRE3 -19-14MAR14-1/1

In Case of Fire

CAUTION: Avoid personal injury.

Stop machine immediately at the first sign of fire. Fire may be identified by the smell of smoke or sight of flames. Because fire grows and spreads rapidly, get off the machine immediately and move safely away from the fire. Do not return to the machine! The number one priority is safety.

Call the fire department. A portable fire extinguisher can put out a small fire or contain it until the fire department arrives; but portable extinguishers have limitations. Always put the safety of the operator and bystanders first. If attempting to extinguish a fire, keep your back to the wind with an unobstructed escape path so you can move away quickly if the fire cannot be extinguished.

Read the fire extinguisher instructions and become familiar with their location, parts, and operation before a fire starts. Local fire departments or fire equipment distributors may offer fire extinguisher training and recommendations.

If your extinguisher does not have instructions, follow these general guidelines:



1. Pull the pin. Hold the extinguisher with the nozzle pointing away from you, and release the locking mechanism.
2. Aim low. Point the extinguisher at the base of the fire.
3. Squeeze the lever slowly and evenly.
4. Sweep the nozzle from side-to-side.

DX,FIRE4 -19-22AUG13-1/1

TS227—UN—15APR13

Handle Fluids Safely—Avoid Fires

When you work around fuel, do not smoke or work near heaters or other fire hazards.

Store flammable fluids away from fire hazards. Do not incinerate or puncture pressurized containers.

Make sure machine is clean of trash, grease, and debris.

Do not store oily rags; they can ignite and burn spontaneously.



DX,FLAME -19-29SEP98-1/1

TS227—UN—15APR13

Avoid Static Electricity Risk When Refueling

The removal of sulfur and other compounds in Ultra-Low Sulfur Diesel (ULSD) fuel decreases its conductivity and increases its ability to store a static charge.

Refineries may have treated the fuel with a static dissipating additive. However, there are many factors that can reduce the effectiveness of the additive over time.

Static charges can build up in ULSD fuel while it is flowing through fuel delivery systems. Static electricity discharge when combustible vapors are present could result in a fire or explosion.

Therefore, it is important to ensure that the entire system used to refuel your machine (fuel supply tank, transfer pump, transfer hose, nozzle, and others) is properly grounded and bonded. Consult with your fuel or fuel system supplier to ensure that the delivery system is in compliance with fueling standards for proper grounding and bonding practices.

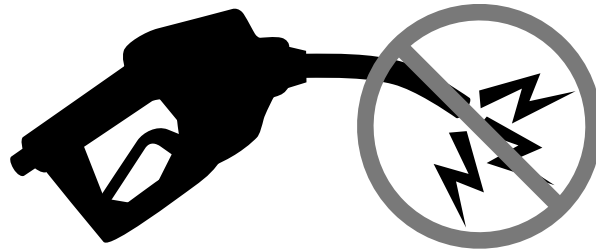

RG22142—UN—17MAR14

RG21992—UN—21AUG13

DX,FUEL,STATIC,ELEC -19-12JUL13-1/1

Service Machines Safely

Tie long hair behind your head. Do not wear a necktie, scarf, loose clothing, or necklace when you work near machine tools or moving parts. If these items were to get caught, severe injury could result.

Remove rings and other jewelry to prevent electrical shorts and entanglement in moving parts.

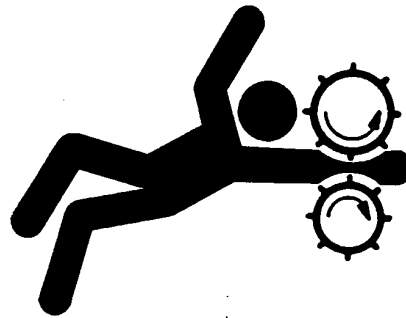

TS228—UN—23AUG88

DX,LOOSE -19-04JUN90-1/1

Wear Protective Clothing

Wear close fitting clothing and safety equipment appropriate to the job.

Operating equipment safely requires the full attention of the operator. Do not wear radio or music headphones while operating machine.

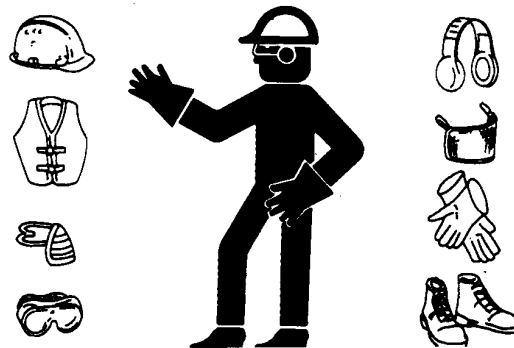

TS206—UN—15APR13

DX,WEAR2 -19-03MAR93-1/1

Protect Against Noise

There are many variables that affect the sound level range, including machine configuration, condition and maintenance level of the machine, ground surface, operating environmental, duty cycles, ambient noise, and attachments.

Exposure to loud noise can cause impairment or loss of hearing.

Always wear hearing protection. Wear a suitable hearing protective device such as earmuffs or earplugs to protect against objectionable or uncomfortable loud noises.



DX,NOISE -19-03OCT17-1/1

TS207 —UN—23AUG88

Handling Batteries Safely

Battery gas can explode. Keep sparks and flames away from batteries. Use a flashlight to check battery electrolyte level.

Never check battery charge by placing a metal object across the posts. Use a voltmeter or hydrometer.

Always remove grounded (-) battery clamp first and replace grounded clamp last.

Sulfuric acid in battery electrolyte is poisonous and strong enough to burn skin, eat holes in clothing, and cause blindness if splashed into eyes.

Avoid hazards by:

- Filling batteries in a well-ventilated area
- Wearing eye protection and rubber gloves
- Avoiding use of air pressure to clean batteries
- Avoiding breathing fumes when electrolyte is added
- Avoiding spilling or dripping electrolyte
- Using correct battery booster or charger procedure.

If acid is spilled on skin or in eyes:

1. Flush skin with water.
2. Apply baking soda or lime to help neutralize the acid.
3. Flush eyes with water for 15—30 minutes. Get medical attention immediately.

If acid is swallowed:

1. Do not induce vomiting.
2. Drink large amounts of water or milk, but do not exceed 2 L (2 qt.).
3. Get medical attention immediately.

WARNING: Battery posts, terminals, and related accessories contain lead and lead compounds, chemicals known to the State of California to cause cancer and reproductive harm. **Wash hands after handling.**

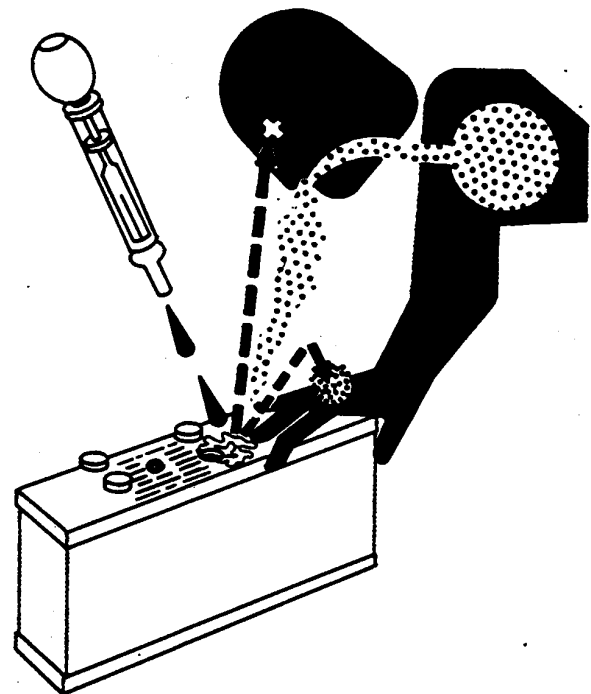

DX,WW,BATTERIES -19-02DEC10-1/1

TS204 —UN—15APR13

TS203 —UN—23AUG88

Prevent Acid Burns

Sulfuric acid in battery electrolyte is poisonous. It is strong enough to burn skin, eat holes in clothing, and cause blindness if splashed into eyes.

Avoid the hazard by:

1. Filling batteries in a well-ventilated area.
2. Wearing eye protection and rubber gloves.
3. Avoiding breathing fumes when electrolyte is added.
4. Avoiding spilling or dripping electrolyte.
5. Use proper jump start procedure.

If you spill acid on yourself:

1. Flush your skin with water.
2. Apply baking soda or lime to help neutralize the acid.
3. Flush your eyes with water for 15—30 minutes. Get medical attention immediately.

If acid is swallowed:

1. Do not induce vomiting.
2. Drink large amounts of water or milk, but do not exceed 2 L (2 quarts).
3. Get medical attention immediately.

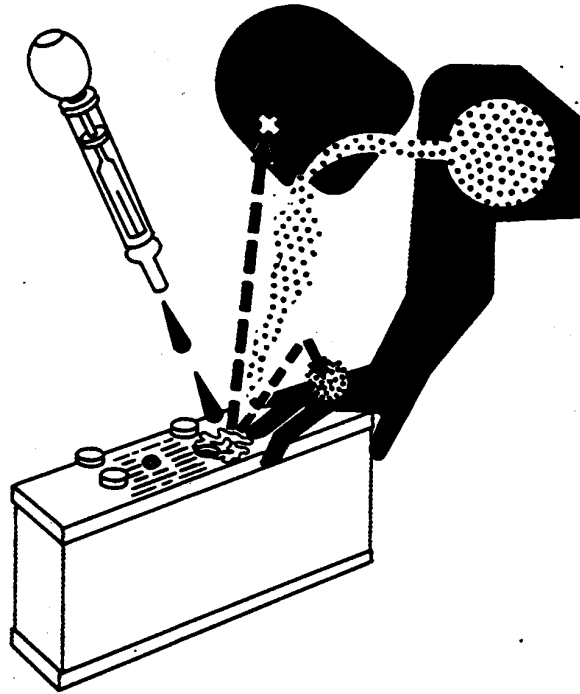

TS203 —UN—23AUG88

DX,POISON -19-21APR93-1/1

Stay Clear of Rotating Drivelines

Entanglement in rotating driveline can cause serious injury or death.

Keep all shields in place at all times. Make sure rotating shields turn freely.

Wear close-fitting clothing. Stop the engine and be sure that all rotating parts and drivelines are stopped before making adjustments, connections, or performing any type of service on engine or machine driven equipment.



TS1644 —UN—22AUG85

DX,ROTATING -19-18AUG09-1/1

Install All Guards

Rotating cooling system fans, belts, pulleys, and drives can cause serious injury.

Keep all guards in place at all times during engine operation.

Wear close-fitting clothes. Stop the engine and be sure fans, belts, pulleys, and drives are stopped before making adjustments, connections, or cleaning near fans and their drive components.

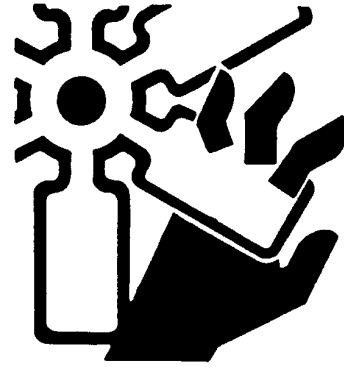

DX, GUARDS -19-18AUG09-1/1

TS677 —UN—21SEP89

Practice Safe Maintenance

Understand service procedure before doing work. Keep area clean and dry.

Never lubricate, service, or adjust machine while it is moving. Keep hands, feet, and clothing away from power-driven parts. Disengage all power and operate controls to relieve pressure. Lower equipment to the ground. Stop the engine. Remove the key. Allow machine to cool.

Securely support any machine elements that must be raised for service work.

Keep all parts in good condition and properly installed. Fix damage immediately. Replace worn or broken parts. Remove any buildup of grease, oil, or debris.

On self-propelled equipment, disconnect battery ground cable (-) before making adjustments on electrical systems or welding on machine.

On towed implements, disconnect wiring harnesses from tractor before servicing electrical system components or welding on machine.

Falling while cleaning or working at height can cause serious injury. Use a ladder or platform to easily reach each location. Use sturdy and secure footholds and handholds.



DX, SERV -19-28FEB17-1/1

TS218 —UN—23AUG88

Remove Paint Before Welding or Heating

Avoid potentially toxic fumes and dust.

Hazardous fumes can be generated when paint is heated by welding, soldering, or using a torch.

Remove paint before heating:

- Remove paint a minimum of 100 mm (4 in.) from area to be affected by heating. If paint cannot be removed, wear an approved respirator before heating or welding.
- If you sand or grind paint, avoid breathing the dust. Wear an approved respirator.
- If you use solvent or paint stripper, remove stripper with soap and water before welding. Remove solvent or paint stripper containers and other flammable material from area. Allow fumes to disperse at least 15 minutes before welding or heating.

Do not use a chlorinated solvent in areas where welding will take place.



Do all work in an area that is well ventilated to carry toxic fumes and dust away.

Dispose of paint and solvent properly.

DX,PAINT -19-24JUL02-1/1

TS220 —UN—15APR13

Avoid Heating Near Pressurized Fluid Lines

Flammable spray can be generated by heating near pressurized fluid lines, resulting in severe burns to yourself and bystanders. Do not heat by welding, soldering, or using a torch near pressurized fluid lines or other flammable materials. Pressurized lines can accidentally burst when heat goes beyond the immediate flame area.



DX,TORCH -19-10DEC04-1/1

TS953 —UN—15MAY90

Avoid High-Pressure Fluids

Inspect hydraulic hoses periodically – at least once per year – for leakage, kinking, cuts, cracks, abrasion, blisters, corrosion, exposed wire braid or any other signs of wear or damage.

Replace worn or damaged hose assemblies immediately with John Deere approved replacement parts.

Escaping fluid under pressure can penetrate the skin causing serious injury.

Avoid the hazard by relieving pressure before disconnecting hydraulic or other lines. Tighten all connections before applying pressure.

Search for leaks with a piece of cardboard. Protect hands and body from high-pressure fluids.

If an accident occurs, see a doctor immediately. Any fluid injected into the skin must be surgically removed within

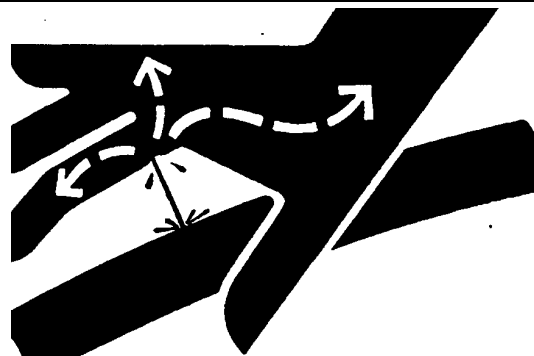

a few hours or gangrene may result. Doctors unfamiliar with this type of injury should reference a knowledgeable medical source. Such information is available in English from Deere & Company Medical Department in Moline, Illinois, U.S.A., by calling 1-800-822-8262 or +1 309-748-5636.

DX,FLUID -19-12OCT11-1/1

X9811 —UN—23AUG88

Do Not Open High-Pressure Fuel System

High-pressure fluid remaining in fuel lines can cause serious injury. Do not disconnect or attempt repair of fuel lines, sensors, or any other components between the high-pressure fuel pump and nozzles on engines with High Pressure Common Rail (HPCR) fuel system.

Only technicians familiar with this type of system can perform repairs. (See your John Deere dealer.)



DX,WW,HPCR1 -19-07JAN03-1/1

TS1343—UN—18MAR92

Protect Against High Pressure Spray

Spray from high pressure nozzles can penetrate the skin and cause serious injury. Keep spray from contacting hands or body.

If an accident occurs, see a doctor immediately. Any high pressure spray injected into the skin must be surgically removed within a few hours or gangrene may result. Doctors unfamiliar with this type of injury should reference a knowledgeable medical source. Such information is available from Deere & Company Medical Department in Moline, Illinois, U.S.A.

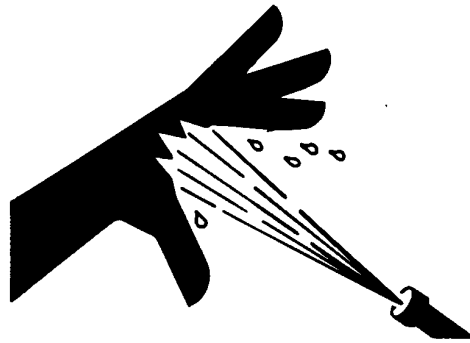

DX,SPRAY -19-16APR92-1/1

TS1343—UN—18MAR92

Prevent Battery Explosions

Keep sparks, lighted matches, and open flame away from the top of battery. Battery gas can explode.

Never check battery charge by placing a metal object across the posts. Use a volt-meter or hydrometer.

Do not charge a frozen battery; it may explode. Warm battery to 16°C (60°F).



DX,SPARKS -19-03MAR93-1/1

TS204—UN—15APR13

Avoid Hot Exhaust

Servicing machine or attachments with engine running can result in serious personal injury. Avoid exposure and skin contact with hot exhaust gases and components.

Exhaust parts and streams become very hot during operation. Exhaust gases and components reach temperatures hot enough to burn people, ignite, or melt common materials.

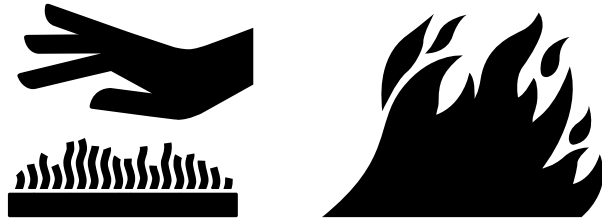

RG17488—JUN—21AUG09

DX,EXHAUST -19-20AUG09-1/1

Work In Ventilated Area

Engine exhaust fumes can cause sickness or death. If it is necessary to run an engine in an enclosed area, remove the exhaust fumes from the area with an exhaust pipe extension.

If you do not have an exhaust pipe extension, open the doors and get outside air into the area.



TS220—JUN—15APR13

DX,AIR -19-17FEB99-1/1

Service Cooling System Safely

Explosive release of fluids from pressurized cooling system can cause serious burns.

Shut off engine. Only remove filler cap when cool enough to touch with bare hands. Slowly loosen cap to first stop to relieve pressure before removing completely.



TS281—JUN—15APR13

DX,VW,COOLING -19-19AUG09-1/1

Decommissioning — Proper Recycling and Disposal of Fluids and Components

Safety and environmental stewardship measures must be taken into account when decommissioning a machine and/or component. These measures include the following:

- Use appropriate tools and personal protective equipment such as clothing, gloves, face shields or glasses, during the removal or handling of objects and materials.
- Follow instructions for specialized components.
- Release stored energy by lowering suspended machine elements, relaxing springs, disconnecting the battery or other electrical power, and releasing pressure in hydraulic components, accumulators, and other similar systems.
- Minimize exposure to components which may have residue from agricultural chemicals, such as fertilizers and pesticides. Handle and dispose of these components appropriately.
- Carefully drain engines, fuel tanks, radiators, hydraulic cylinders, reservoirs, and lines before recycling components. Use leak-proof containers when draining fluids. Do not use food or beverage containers.
- Do not pour waste fluids onto the ground, down a drain, or into any water source.
- Observe all national, state, and local laws, regulations, or ordinances governing the handling or disposal of waste fluids (example: oil, fuel, coolant, brake fluid);

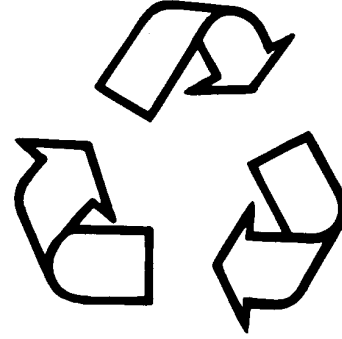

- filters; batteries; and, other substances or parts. Burning of flammable fluids or components in other than specially designed incinerators may be prohibited by law and could result in exposure to harmful fumes or ashes.
- Service and dispose of air conditioning systems appropriately. Government regulations may require a certified service center to recover and recycle air conditioning refrigerants which could damage the atmosphere if allowed to escape.
 - Evaluate recycling options for tires, metal, plastic, glass, rubber, and electronic components which may be recyclable, in part or completely.
 - Contact your local environmental or recycling center, or your John Deere dealer for information on the proper way to recycle or dispose of waste.

DX.DRAIN -19-01JUN15-1/1

TSS1133—JUN—15APR13

Fuels, Lubricants, and Coolant

Diesel Fuel

Consult your local fuel distributor for properties of the diesel fuel available in your area.

In general, diesel fuels are blended to satisfy the low temperature requirements of the geographical area in which they are marketed.

Diesel fuels specified to EN 590 or ASTM D975 are recommended. Renewable diesel fuel produced by hydrotreating animal fats and vegetable oils is basically identical to petroleum diesel fuel. Renewable diesel that meets EN 590, ASTM D975, or EN 15940 is acceptable for use at all percentage mixture levels.

Required Fuel Properties

In all cases, the fuel shall meet the following properties:

Cetane number of 40 minimum. Cetane number greater than 47 is preferred, especially for temperatures below -20°C (-4°F) or elevations above 1675 m (5500 ft.).

Cloud Point should be below the expected lowest ambient temperature or **Cold Filter Plugging Point (CFPP)** should be a maximum 10°C (18°F) below the fuel cloud point.

Fuel lubricity should pass a maximum scar diameter of 0.52 mm as measured by ASTM D6079 or ISO 12156-1. A maximum scar diameter of 0.45 mm is preferred.

Diesel fuel quality and sulfur content must comply with all existing emissions regulations for the area in which the engine operates. DO NOT use diesel fuel with sulfur content greater than 10 000 mg/kg (10 000 ppm).

E-Diesel fuel

DO NOT use E-Diesel (Diesel fuel and ethanol blend). Use of E-Diesel fuel in any John Deere machine may void the machine warranty.

⚠ CAUTION: Avoid severe injury or death due to the fire and explosion risk from using E-Diesel fuel.

¹See DX,ENOIL12,OEM, DX,ENOIL12,T2,STD, or DX,ENOIL12,T2,EXT for more information on Engine Oil and Filter Service Intervals.

Sulfur content for Interim Tier 4, Final Tier 4, Stage III B, Stage IV Engines, and Stage V engines

- Use ONLY ultra low sulfur diesel (ULSD) fuel with a maximum of 15 mg/kg (15 ppm) sulfur content.

Sulfur Content for Tier 3 and Stage III A Engines

- Use of diesel fuel with sulfur content less than 1000 mg/kg (1000 ppm) is RECOMMENDED.
- Use of diesel fuel with sulfur content 1000—2000 mg/kg (1000—2000 ppm) REDUCES the oil and filter change interval.
- BEFORE using diesel fuel with sulfur content greater than 2000 mg/kg (2000 ppm), contact your John Deere dealer.

Sulfur Content for Tier 2 and Stage II Engines

- Use of diesel fuel with sulfur content less than 2000 mg/kg (2000 ppm) is RECOMMENDED.
- Use of diesel fuel with sulfur content 2000—5000 mg/kg (2000—5000 ppm) REDUCES the oil and filter change interval.¹
- BEFORE using diesel fuel with sulfur content greater than 5000 mg/kg (5000 ppm), contact your John Deere dealer.

Sulfur Content for Other Engines

- Use of diesel fuel with sulfur content less than 5000 mg/kg (5000 ppm) is RECOMMENDED.
- Use of diesel fuel with sulfur content greater than 5000 mg/kg (5000 ppm) REDUCES the oil and filter change interval.

IMPORTANT: Do not mix used diesel engine oil or any other type of lubricating oil with diesel fuel.

Improper fuel additive usage may cause damage on fuel injection equipment of diesel engines.

DX,FUEL1 -19-13JAN18-1/1

Supplemental Diesel Fuel Additives

Diesel fuel can be the source of performance or other operational problems for many reasons. Some causes include poor lubricity, contaminants, low cetane number, and a variety of properties that cause fuel system deposits. These and others are referenced in other sections of this Operator's Manual.

To optimize engine performance and reliability, closely follow recommendations on fuel quality, storage, and handling, which are found elsewhere in this Operator's Manual.

To further aid in maintaining performance and reliability of the engine's fuel system, John Deere has developed a family of fuel additive products for most global markets. The primary products include Fuel-Protect Diesel Fuel Conditioner (full feature conditioner in winter and summer formulas) and Fuel-Protect Keep Clean (fuel injector deposit removal and prevention). Availability of these and other products varies by market. See your local John Deere dealer for availability and additional information about fuel additives that might be right for your needs.

DX,FUEL13 -19-07FEB14-1/1

Lubricity of Diesel Fuel

Most diesel fuels manufactured in the United States, Canada, and the European Union have adequate lubricity to ensure proper operation and durability of fuel injection system components. However, diesel fuels manufactured in some areas of the world may lack the necessary lubricity.

IMPORTANT: Make sure the diesel fuel used in your machine demonstrates good lubricity characteristics.

Fuel lubricity should pass a maximum scar diameter of 0.52 mm as measured by ASTM D6079 or ISO 12156-1. A maximum scar diameter of 0.45 mm is preferred.

If fuel of low or unknown lubricity is used, add John Deere Fuel-Protect Diesel Fuel Conditioner (or equivalent) at the specified concentration.

Lubricity of BioDiesel Fuel

Fuel lubricity can improve significantly with BioDiesel blends up to B20 (20% BioDiesel). Further increase in lubricity is limited for BioDiesel blends greater than B20.

DX,FUEL5 -19-07FEB14-1/1

Handling and Storing Diesel Fuel

⚠ CAUTION: Reduce the risk of fire. Handle fuel carefully. DO NOT fill the fuel tank when engine is running. DO NOT smoke while you fill the fuel tank or service the fuel system.

Fill the fuel tank at the end of each day's operation to prevent water condensation and freezing during cold weather.

Keep all storage tanks as full as practical to minimize condensation.

Ensure that all fuel tank caps and covers are installed properly to prevent moisture from entering. Monitor water content of the fuel regularly.

When using biodiesel fuel, the fuel filter may require more frequent replacement due to premature plugging.

Check engine oil level daily prior to starting engine. A rising oil level may indicate fuel dilution of the engine oil.

IMPORTANT: The fuel tank is vented through the filler cap. If a new filler cap is required, always replace it with an original vented cap.

When fuel is stored for an extended period or if there is a slow turnover of fuel, add a fuel conditioner to stabilize the fuel. Keeping the free water drained and treating the bulk fuel storage tank quarterly with a maintenance dose of a biocide will prevent microbial growth. Contact your fuel supplier or John Deere dealer for recommendations.

DX,FUEL4 -19-13JAN18-1/1

Biodiesel Fuel

Biodiesel fuel is comprised of monoalkyl esters of long chain fatty acids derived from vegetable oils or animal fats. Biodiesel blends are biodiesel mixed with petroleum diesel fuel on a volume basis.

Before using fuel containing biodiesel, review the Biodiesel Use Requirements and Recommendations in this Operator's Manual.

Environmental laws and regulations can encourage or prohibit the use of biofuels. Operators should consult with appropriate governmental authorities prior to using biofuels.

John Deere Stage V Engines Operating in the European Union

Where the engine is to be operated within the Union on diesel or non-road gas-oil, a fuel with a FAME content not greater than 8% volume/volume (B8) shall be used.

John Deere Engines with Exhaust Filter Except Stage V Engines Operating in the European Union

Biodiesel blends up to B20 can be used ONLY if the biodiesel (100% biodiesel or B100) meets ASTM D6751, EN 14214, or equivalent specification. Expect a 2% reduction in power and a 3% reduction in fuel economy when using B20.

Biodiesel concentrations above B20 can harm the engine's emission control systems and should not be used. Risks include, but are not limited to, more frequent stationary regeneration, soot accumulation, and increased intervals for ash removal.

John Deere Fuel conditioners or equivalent, which contain detergent and dispersant additives, are required when using biodiesel blends from B10 to B20, and are recommended when using lower biodiesel blends.

John Deere Engines Without Exhaust Filter

Biodiesel blends up to B20 can be used ONLY if the biodiesel (100% biodiesel or B100) meets ASTM D6751, EN 14214, or equivalent specification. Expect a 2% reduction in power and a 3% reduction in fuel economy when using B20.

These John Deere engines can operate on biodiesel blends above B20 (up to 100% biodiesel). Operate at levels above B20 ONLY if the biodiesel is permitted by law and meets the EN 14214 specification (primarily available in Europe). Engines operating on biodiesel blends above B20 might not fully comply with or be permitted by all applicable emissions regulations. Expect up to a 12% reduction in power and an 18% reduction in fuel economy when using 100% biodiesel.

John Deere fuel conditioners or equivalent, which contain detergent and dispersant additives, are required when using biodiesel blends from B10 to B100, and are recommended when using lower biodiesel blends.

Biodiesel Use Requirements and Recommendations

The petroleum diesel portion of all biodiesel blends must meet the requirements of ASTM D975 (US) or EN 590 (EU) commercial standard.

Biodiesel users in the U.S. are strongly encouraged to purchase biodiesel blends from a BQ-9000 Certified Marketer and sourced from a BQ-9000 Accredited Producer (as certified by the National Biodiesel Board). Certified Marketers and Accredited Producers can be found at the following website: <http://www.bq9000.org>.

Biodiesel contains residual ash. Ash levels exceeding the maximums allowed in either ASTM D6751 or EN14214 can result in more rapid ash loading and require more frequent cleaning of the Exhaust Filter (if present).

The fuel filter can require more frequent replacement when using biodiesel fuel, particularly if switching from diesel. Check engine oil level daily prior to starting engine. A rising oil level can indicate fuel dilution of the engine oil. Biodiesel blends up to B20 must be used within 90 days of the date of biodiesel manufacture. Biodiesel blends above B20 must be used within 45 days from the date of biodiesel manufacture.

When using biodiesel blends up to B20, the following must be considered:

- Cold-weather flow degradation
- Stability and storage issues (moisture absorption, microbial growth)
- Possible filter restriction and plugging (usually a problem when first switching to biodiesel on used engines)
- Possible fuel leakage through seals and hoses (primarily an issue with older engines)
- Possible reduction of service life of engine components

Request a certificate of analysis from your fuel distributor to ensure that the fuel is compliant with the specifications provided in this Operator's Manual.

Consult your John Deere dealer for John Deere fuel products to improve storage and performance with biodiesel fuels.

The following must also be considered if using biodiesel blends above B20:

- Possible coking or blocked injector nozzles, resulting in power loss and engine misfire if John Deere fuel additives and conditioners or equivalent containing detergent/dispersants are not used
- Possible crankcase oil dilution (requiring more frequent oil changes)
- Possible lacquering or seizure of internal components
- Possible formation of sludge and sediments
- Possible thermal oxidation of fuel at elevated temperatures

Continued on next page

DX,FUEL7 -19-13JAN18-1/2

- Possible compatibility issues with other materials (including copper, lead, zinc, tin, brass, and bronze) used in fuel handling, distribution, and storage equipment
- Possible reduction in water separator efficiency
- Possible damage to paint if exposed to biodiesel
- Possible corrosion of fuel injection equipment
- Possible elastomeric seal and gasket material degradation (primarily an issue with older engines)
- Possible high acid levels within fuel system

- Because biodiesel blends above B20 contain more ash, using blends above B20 can result in more rapid ash loading and require more frequent cleaning of the Exhaust Filter (if present)

IMPORTANT: Raw pressed vegetable oils are NOT acceptable for use as fuel in any concentration in John Deere engines. Their use could cause engine failure.

DX,FUEL7 -19-13JAN18-2/2

Testing Diesel Fuel

A fuel analysis program can help to monitor the quality of diesel fuel. The fuel analysis can provide critical data such as calculated cetane index, fuel type, sulfur content, water content, appearance, suitability for cold weather

operations, bacteria, cloud point, acid number, particulate contamination, and whether the fuel meets ASTM D975 or equivalent specification.

Contact your John Deere dealer for more information on diesel fuel analysis.

DX,FUEL6 -19-13JAN18-1/1

Aviation (Jet) Fuels

IMPORTANT: Not all fuels should be considered for regular use. Some fuels that can be used in this engine are for emergency only and can cause premature engine and component wear if used long term. Unless your engine has been specifically designed for prolonged use of aviation fuel, the following fuels should be used for an emergency only fuel alternative.

Aviation (jet) fuels may be used with the following restrictions.

Type	Comments
Jet A	Not Recommended. Lower viscosity and density than base No. 2-D diesel fuel. Power loss up to 10% can be expected.
Jet A-1	Not Recommended. Lower viscosity and density than base No. 2-D diesel fuel. Power loss up to 10% can be expected. May be used as an emergency fuel only, with the addition of John Deere PREMIUM DIESEL FUEL CONDITIONER (or equivalent) at the specified concentration.
Jet B	Not Recommended. Lower density and extremely low viscosity compared to base No. 2-D diesel fuel. Power loss up to 14% can be expected. May be used as an emergency fuel only, with the addition of John Deere PREMIUM DIESEL FUEL CONDITIONER (or equivalent) at the specified concentration.
JP-4	Not Recommended. Lower density and extremely low viscosity compared to base No. 2-D diesel fuel. Power loss up to 14% can be expected. May be used as an emergency fuel only, with the addition of John Deere PREMIUM DIESEL FUEL CONDITIONER (or equivalent) at the specified concentration.
JP-5	Not Recommended. Lower viscosity and density than base No. 2-D diesel fuel. Power loss up to 10% can be expected.
JP-7	Not Recommended. Lower viscosity and density than base No. 2-D diesel fuel. Power loss up to 10% can be expected.
JP-8	Not Recommended. Lower viscosity and density than base No. 2-D diesel fuel. Power loss up to 10% can be expected.

OURGP12,000003F -19-16AUG11-1/1

Burner Fuels

Burner fuels, like kerosene, may be used with the following restrictions.

Type	Comments
No.2	Higher density and specific gravity than base No. 2-D diesel fuel. Power increase up to 3% can be expected.
No.1	Lower viscosity than base No. 2-D diesel fuel. Power loss up to 2% can be expected.

OURGP12,0000040 -19-07JUL04-1/1

Fuel Filters

The importance of fuel filtration cannot be overemphasized with modern fuel systems. The combination of increasingly restrictive emission regulations and more efficient engines requires fuel system to operate at much higher pressures. Higher pressures can only be achieved using fuel injection components with very close tolerances. These close

manufacturing tolerances have significantly reduced capacities for debris and water.

John Deere brand fuel filters have been designed and produced specifically for John Deere engines.

To protect the engine from debris and water, always change engine fuel filters as specified in this manual.

DX,FILT2 -19-14APR11-1/1

Minimizing the Effect of Cold Weather on Diesel Engines

John Deere diesel engines are designed to operate effectively in cold weather.

However, for effective starting and cold-weather operation, a little extra care is necessary. The following information outlines steps that can minimize the effect that cold weather may have on starting and operation of your engine. See your John Deere dealer for additional information and local availability of cold-weather aids.

Use Winter Grade Fuel

When temperatures fall below 0°C (32°F), winter grade fuel (No. 1-D in North America) is best suited for cold-weather operation. Winter grade fuel has a lower cloud point and a lower pour point.

Cloud point is the temperature at which wax begins to form in the fuel. This wax causes fuel filters to plug. **Pour point** is the lowest temperature at which movement of the fuel is observed.

NOTE: On average, winter grade diesel fuel has a lower Btu (heat content) rating. Using winter grade fuel may reduce power and fuel efficiency, but should not cause any other engine performance effects. Check the grade of fuel being used before troubleshooting for low-power complaints in cold-weather operation.

Air Intake Heater

An air intake heater is an available option for some engines to aid cold weather starting.

Ether

An ether port on the intake is available to aid cold weather starting.

⚠ CAUTION: Ether is highly flammable. Do not use ether when starting an engine equipped with glow plugs or an air intake heater.

Coolant Heater

An engine block heater (coolant heater) is an available option to aid cold weather starting.

Seasonal Viscosity Oil and Proper Coolant Concentration

Use seasonal grade viscosity engine oil based on the expected air temperature range between oil changes and a proper concentration of low silicate antifreeze as recommended. (See DIESEL ENGINE OIL and ENGINE COOLANT requirements in this section.)

Diesel Fuel Cold Flow Additive

Use John Deere Fuel-Protect Diesel Fuel Conditioner (winter formula), which contains anti-gel chemistry, or equivalent fuel conditioner to treat non-winter grade fuel (No. 2-D in North America) during the cold-weather season. This generally extends operability to about 10°C (18°F) below the fuel cloud point. For operability at even lower temperatures, use winter grade fuel.

IMPORTANT: Treat fuel when outside temperature drops below 0°C (32°F). For best results, use with untreated fuel. Follow all recommended instructions on label.

Biodiesel

When operating with biodiesel blends, wax formation can occur at warmer temperatures. Begin using John Deere Fuel-Protect Diesel Fuel Conditioner (winter formula) or equivalent at 5°C (41°F) to treat biodiesel fuels during the cold-weather season. Use B5 or lower blends at temperatures below 0°C (32°F). Use only winter grade petroleum diesel fuel at temperatures below -10°C (14°F).

Winterfronts

Use of fabric, cardboard, or solid winterfronts is not recommended with any John Deere engine. Their use can result in excessive engine coolant, oil, and charge air temperatures. This can lead to reduced engine life, loss of power and poor fuel economy. Winterfronts may also put abnormal stress on fan and fan drive components potentially causing premature failures.

If winterfronts are used, they should never totally close off the grill frontal area. Approximately 25% area in the center of the grill should remain open at all times. At no time should the air blockage device be applied directly to the radiator core.

Radiator Shutters

If equipped with a thermostatically controlled radiator shutter system, this system should be regulated in such a way that the shutters are completely open by the time the coolant reaches 93°C (200°F) to prevent excessive intake manifold temperatures. Manually controlled systems are not recommended.

If air-to-air aftercooling is used, the shutters must be completely open by the time the intake manifold air temperature reaches the maximum allowable temperature out of the charge air cooler.

For more information, see your John Deere dealer.

DX,FUEL10 -19-13JAN18-1/1

Diesel Engine Break-In Oil — Non-Emissions Certified and Certified Tier 1, Tier 2, Tier 3, Stage I, Stage II, and Stage III

New engines are filled at the factory with either John Deere Break-In™ or John Deere Break-In Plus™ Engine Oil. During the break-in period, add John Deere Break-In™ or Break-In Plus™ Engine Oil, respectively, as needed to maintain the specified oil level.

Operate the engine under various conditions, particularly heavy loads with minimal idling, to help seat engine components properly.

If John Deere Break-In™ Engine Oil is used during the initial operation of a new or rebuilt engine, change the oil and filter at a maximum of 100 hours.

If John Deere Break-In Plus™ Engine Oil is used, change the oil and filter at a minimum of 100 hours and a maximum equal to the interval specified for John Deere Plus-50™ II or Plus-50™ oil.

After engine overhaul, fill the engine with either John Deere Break-In™ or Break-In Plus™ Engine Oil.

If John Deere Break-In™ or Break-In Plus™ Engine Oil is not available, use an SAE 10W-30 viscosity grade diesel engine oil meeting one of the following and change the oil and filter at a maximum of 100 hours of operation:

- API Service Classification CE
- API Service Classification CD
- API Service Classification CC

*Break-In is a trademark of Deere & Company.
Break-In Plus is a trademark of Deere & Company
Plus-50 is a trademark of Deere & Company.*

- ACEA Oil Sequence E2
- ACEA Oil Sequence E1

IMPORTANT: Do not use Plus-50™ II, Plus-50™, or engine oils meeting any of the following for the initial break-in of a new or rebuilt engine:

API CK-4	ACEA E9
API CJ-4	ACEA E7
API CI-4 PLUS	ACEA E6
API CI-4	ACEA E5
API CH-4	ACEA E4
API CG-4	ACEA E3
API CF-4	
API CF-2	
API CF	

These oils do not allow the engine to break in properly.

John Deere Break-In Plus™ Engine Oil can be used for all John Deere diesel engines at all emission certification levels.

After the break-in period, use John Deere Plus-50™ II, John Deere Plus-50™, or other diesel engine oil as recommended in this manual.

DX,ENOIL4 -19-02NOV16-1/1

Diesel Engine Oil — Non-Emissions Certified and Certified Tier 1 and Stage I

Failure to follow applicable oil standards and drain intervals can result in severe engine damage that might not be covered under warranty. Warranties, including the emissions warranty, are not conditioned on the use of John Deere oils, parts, or service.

Use oil viscosity based on the expected air temperature range during the period between oil changes.

John Deere Plus-50™ II oil is preferred.

John Deere Plus-50™ is also recommended.

John Deere Torq-Gard™ is also allowed.

Other oils may be used if they meet one or more of the following standards:

- API Service Category CK-4
- API Service Category CJ-4
- API Service Category CI-4 PLUS
- API Service Category CI-4
- API Service Category CH-4
- API Service Category CG-4
- API Service Category CF-4
- ACEA Oil Sequence E9
- ACEA Oil Sequence E7
- ACEA Oil Sequence E6
- ACEA Oil Sequence E5
- ACEA Oil Sequence E4
- ACEA Oil Sequence E3
- ACEA Oil Sequence E2

If oils meeting API CG-4, API CF-4, or ACEA E2 are used, reduce the service interval by 50%.

Multi-viscosity diesel engine oils are preferred.

*Plus-50 is a trademark of Deere & Company
Torq-Gard is a trademark of Deere & Company*

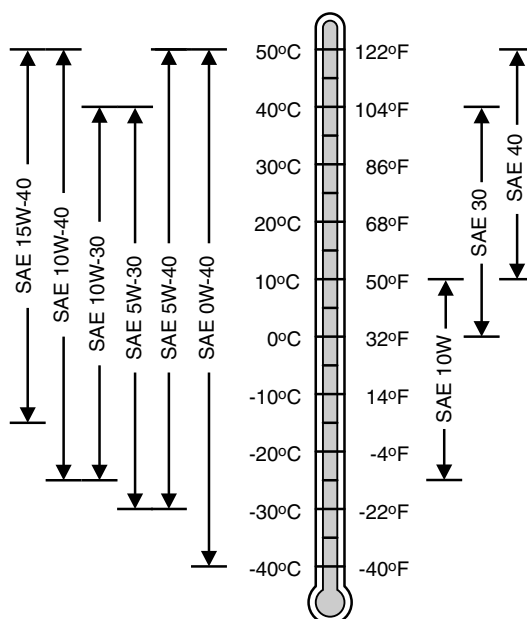

Oil Viscosities for Air Temperature Ranges

Diesel fuel quality and fuel sulfur content must comply with all existing emissions regulations for the area in which the engine operates.

If diesel fuel with sulfur content greater than 5000 mg/kg (5000 ppm) is used, reduce the service interval by 50%.

DO NOT use diesel fuel with sulfur content greater than 10 000 mg/kg (10 000 ppm).

TS1743 —UN—25APR19

DX,ENOIL -19-23APR19-1/1

Extended Diesel Engine Oil Service Intervals — Non-Emissions Certified and Certified Tier 1 and Stage I

When John Deere Plus-50™ II or John Deere Plus-50™ is used with the specified John Deere filter, the service interval for engine oil and filter changes may be increased by 50% but not to exceed a maximum of 500 hours.

Use oil analysis to evaluate the condition of the oil and to aid in selection of the proper oil and filter service interval. Contact your John Deere dealer or other qualified service provider for more information on engine oil analysis.

Change the oil and oil filter at least once every 12 months even if the hours of operation are fewer than the otherwise recommended service interval.

When ACEA E9, ACEA E7, ACEA E6, ACEA E5, or ACEA E4 oils are used with specified John Deere filter, use engine oil analysis to determine if the service interval for engine oil and filter changes may be increased by a maximum of 50%, but not to exceed 500 hours. Oil analysis means taking a series of oil samples at 50 hour increments beyond the normal service interval until either the data indicates the end of useful oil life or the maximum service interval is reached.

*Plus-50 is a trademark of Deere & Company
Torq-Gard is a trademark of Deere & Company*

If John Deere Plus-50™ II or John Deere Plus-50™, ACEA E9, ACEA E7, ACEA E6, ACEA E5, or ACEA E4 oils are used with other than the specified John Deere filter, change the engine oil and filter at the normal service interval.

If John Deere Torq-Gard™, API CK-4, API CJ-4, API CI-4 PLUS, API CI-4, API CH-4, or ACEA E3 oils are used, change the engine oil and filter at the normal service interval.

If API CG-4, API CF-4, or ACEA E2 oils are used, change the engine oil and filter at 50% of the normal service interval.

IMPORTANT: To avoid engine damage:

- **Reduce oil and filter service intervals by 50% when using biodiesel blends greater than B20. Oil analysis may allow longer service intervals**
- **Use only approved oil types**

DX,ENOIL6 -19-13JAN18-1/1

Mixing of Lubricants

In general, avoid mixing different brands or types of oil. Oil manufacturers blend additives in their oils to meet certain specifications and performance requirements.

Mixing different oils can interfere with the proper functioning of these additives and degrade lubricant performance.

Consult your John Deere dealer to obtain specific information and recommendations.

DX,LUBMIX -19-18MAR96-1/1

Alternative and Synthetic Lubricants

Conditions in certain geographical areas may require lubricant recommendations different from those printed in this manual.

Some John Deere brand coolants and lubricants may not be available in your location.

Consult your John Deere dealer to obtain information and recommendations.

Synthetic lubricants may be used if they meet the performance requirements as shown in this manual.

The temperature limits and service intervals shown in this manual apply to John Deere branded fluids or fluids that have been tested and/or approved for use in John Deere equipment.

Re-refined base stock products may be used if the finished lubricant meets the performance requirements.

DX,ALTER -19-13JAN18-1/1

Lubricant Storage

Your equipment can operate at top efficiency only when clean lubricants are used.

Use clean containers to handle all lubricants.

Store lubricants and containers in an area protected from dust, moisture, and other contamination. Store containers on their side to avoid water and dirt accumulation.

Make certain that all containers are properly marked to identify their contents.

Properly dispose of all old containers and any residual lubricant they may contain.

DX,LUBST -19-11APR11-1/1

Oil Filters

Filtration of oils is critical to proper operation and lubrication.

Always change filters regularly as specified in this manual.

Use filters meeting John Deere performance specifications.

DX,FILT -19-18MAR96-1/1

Diesel Engine Coolant (engine with wet sleeve cylinder liners)

Failure to follow applicable coolant standards and drain intervals can result in severe engine damage that may not be covered under warranty. Warranties, including the emissions warranty, are not conditioned on the use of John Deere coolants, parts or service.

Preferred Coolants

Failure to follow applicable coolant standards and drain intervals can result in severe engine damage that may not be covered under warranty. Warranties, including the emissions warranty, are not conditioned on the use of John Deere coolants, parts, or service.

The following pre-mix engine coolants are preferred:

- John Deere COOL-GARD™ II
- John Deere COOL-GARD II PG

COOL-GARD II pre-mix coolant is available in several concentrations with different freeze protection limits as shown in the following table.

COOL-GARD II Pre-Mix	Freeze Protection Limit
COOL-GARD II 20/80	-9°C (16°F)
COOL-GARD II 30/70	-16°C (3°F)
COOL-GARD II 50/50	-37°C (-34°F)
COOL-GARD II 55/45	-45°C (-49°F)
COOL-GARD II PG 60/40	-49°C (-56°F)
COOL-GARD II 60/40	-52°C (-62°F)

Not all COOL-GARD II pre-mix products are available in all countries.

Use COOL-GARD II PG when a non-toxic coolant formulation is required.

Additional Recommended Coolants

The following engine coolant is also recommended:

- John Deere COOL-GARD II Concentrate in a 40—60% mixture of concentrate with quality water.

IMPORTANT: When mixing coolant concentrate with water, do not use less than 40% or greater than 60% concentration of coolant. Less than 40% gives inadequate additives for corrosion protection. Greater than 60% can result in coolant gelation and cooling system problems.

COOL-GARD is a trademark of Deere & Company

¹Coolant analysis may extend the service interval of other "Coolants" to a maximum not to exceed the interval of Cool-Gard II coolants. Coolant analysis means taking a series of coolant samples at 1000 hour increments beyond the normal service interval until either the data indicate the end of useful coolant life or the maximum service interval of Cool-Gard II is reached.

Other Coolants

Other ethylene glycol or propylene glycol base coolants may be used if they meet the following specification:

- Pre-mix coolant meeting ASTM D6210 requirements
- Are nitrite-free
- Coolant concentrate meeting ASTM D6210 requirements in a 40—60% mixture of concentrate with quality water

If coolant meeting one of these specifications is unavailable, use a coolant concentrate or pre-mix coolant that has a minimum of the following chemical and physical properties:

- Provides cylinder liner cavitation protection according to either the John Deere Cavitation Test Method or a fleet study run at or above 60% load capacity
- Is formulated with a nitrite-free additive package
- Protects the cooling system metals (cast iron, aluminum alloys, and copper alloys such as brass) from corrosion

Water Quality

Water quality is important to the performance of the cooling system. Deionized or demineralized water is recommended for mixing with ethylene glycol and propylene glycol base engine coolant concentrate.

Coolant Drain Intervals

Drain and flush the cooling system and refill with fresh coolant at the indicated interval, which varies with the coolant used.

When COOL-GARD II or COOL-GARD II PG is used, the drain interval is 6 years or 6000 hours of operation.

If a coolant other than COOL-GARD II or COOL-GARD II PG is used, reduce the drain interval to 2 years or 2000 hours of operation.¹

IMPORTANT: Do not use cooling system sealing additives or antifreeze that contains sealing additives.

Do not mix ethylene glycol and propylene glycol base coolants.

Do not use coolants that contain nitrites.

Water Quality for Mixing with Coolant Concentrate

Engine coolants are a combination of three chemical components: ethylene glycol (EG) or propylene glycol (PG) antifreeze, inhibiting coolant additives, and quality water.

Water quality is important to the performance of the cooling system. Deionized or demineralized water is recommended for mixing with ethylene glycol and propylene glycol base engine coolant concentrate.

All water used in the cooling system should meet the following minimum specifications for quality:

Chlorides	<40 mg/L
Sulfates	<100 mg/L
Total solids	<340 mg/L
Total dissolved hardness	<170 mg/L
pH	5.5—9.0

IMPORTANT: Do not use bottled drinking water because it often contains higher concentrations of total dissolved solids.

Freeze Protection

The relative concentrations of glycol and water in the engine coolant determine its freeze protection limit.

Ethylene Glycol	Freeze Protection Limit
40%	-24°C (-12°F)
50%	-37°C (-34°F)
60%	-52°C (-62°F)
Propylene Glycol	Freeze Protection Limit
40%	-21°C (-6°F)
50%	-33°C (-27°F)
60%	-49°C (-56°F)

DO NOT use a coolant-water mixture greater than 60% ethylene glycol or 60% propylene glycol.

DX,COOL19 -19-13JAN18-1/1

Operating in Warm Temperature Climates

John Deere engines are designed to operate using recommended engine coolants.

Always use a recommended engine coolant, even when operating in geographical areas where freeze protection is not required.

IMPORTANT: Water may be used as coolant in emergency situations only.

Foaming, hot surface aluminum and iron corrosion, scaling, and cavitation occur when water is used as the coolant, even when coolant conditioners are added.

Drain cooling system and refill with recommended engine coolant as soon as possible.

DX,COOL6 -19-15MAY13-1/1

Testing Coolant Freeze Point

The use of a handheld coolant refractometer is the quickest, easiest, and most accurate method to determine coolant freeze point. This method is more accurate than a test strip or a float-type hydrometer which can produce poor results.

A coolant refractometer is available through your John Deere dealer under the SERVICEGARD™ tool program. Part number 75240 provides an economical solution to accurate freeze point determination in the field.

To use this tool:

1. Allow cooling system to cool to ambient temperatures.
2. Open radiator cap to expose coolant.
3. With the included dropper, collect a small coolant sample.
4. Open the lid of the refractometer, place one drop of coolant on the window and close the lid.
5. Look through the eyepiece and focus as necessary.
6. Record the listed freeze point for the type of coolant (ethylene glycol coolant or propylene glycol) being tested.



SERVICEGARD™ Part Number 75240

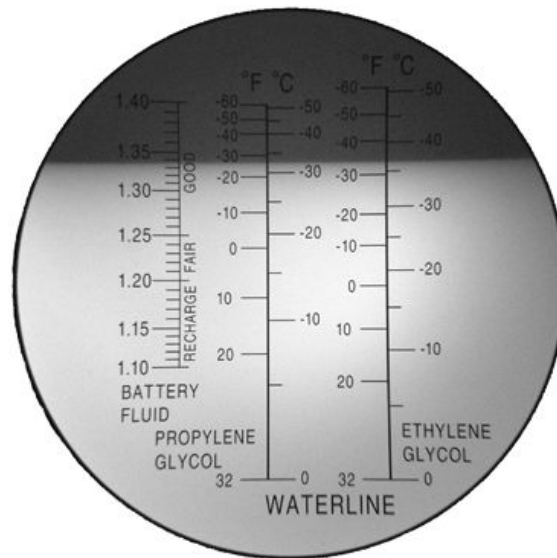

Image with a Drop of 50/50 Coolant Placed on the Refractometer Window

SERVICEGARD is a trademark of Deere & Company

DX,COOL,TEST -19-13JUN13-1/1

TS1732—UN—04SEP13

TS1733—UN—04SEP13

Disposing of Coolant

Improperly disposing of engine coolant can threaten the environment and ecology.

Use leakproof containers when draining fluids. Do not use food or beverage containers that may mislead someone into drinking from them.

Do not pour waste onto the ground, down a drain, or into any water source.

Inquire on the proper way to recycle or dispose of waste from your local environmental or recycling center, or from your John Deere engine distributor or servicing dealer.

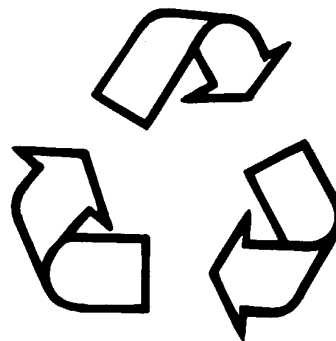

Recycle Waste

RG, RG34710, 7543 -19-26APR18-1/1

TS1133—UN—15APR13

Engine Operating Guidelines

Instrument (Gauge) Panels

All controls and gauges are optional equipment for John Deere OEM Engines. They may be provided by the equipment manufacturer instead of John Deere. The following information applies only to those controls and gauges provided by John Deere.

IMPORTANT: Any time an electric gauge or meter does not register correctly, replace it with a new one. Do not attempt to repair it.

Two types of instrument panels are offered on 4.5 L and 6.8 L engines, as shown on this page. See following for complete information on each type of instrument panel.



North American Instrument Panel

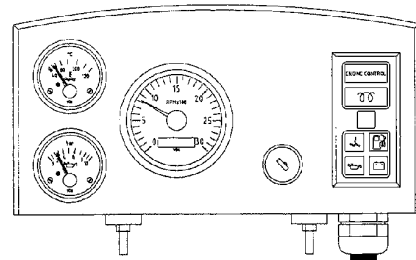

VDO Instrument Panel (Except North America)

DPSG, RG34710, 107 -19-10JAN02-1/1

RG11299—UN—12SEP00

RG10606A—UN—19JUN00

Instrument (Gauge) Panel (North America)

All controls and gauges are optional equipment for John Deere OEM Engines. They may be provided by the equipment manufacturer instead of John Deere. The following information applies only to those controls and gauges provided by John Deere.

IMPORTANT: Any time an electric gauge or meter does not register correctly, replace it with a new one. Do not attempt to repair it.

Following is a brief description of the components on the instrument (gauge) panel:

A—Oil Pressure Gauge - This gauge indicates oil pressure. It also has an adjustable electrical contact which activates the safety switch when oil pressure goes below the pressure set point. This will automatically stop the engine.

B—Coolant Temperature Gauge - This gauge indicates coolant temperature. It also has an electrical contact which activates the safety switch when coolant temperature goes above the temperature set point. This will automatically stop the engine.

C—Key Switch - The key switch is used to start and stop the engine. A key is required to operate the switch so as to prevent unauthorized operation of the engine.

D—Tachometer - The tachometer indicates engine speed in hundreds of revolutions per minute (rpm).

E—Safety Switch (Reset Button) - The safety switch de-energizes the fuel shut-off solenoid or injection rack puller to stop the engine, if one or more conditions are met:

- Low or no oil pressure
- High coolant temperature
- Low crankcase oil level (if equipped with engine oil level switch)
- High crankcase oil level (if equipped with engine oil level switch)

The reset button has to be held in when starting the engine. The button allows the safety switch to override the shut-down circuits until safe engine oil pressure is maintained. Once engine oil pressure is within specifications, the safety switch will latch and the reset button can be released.

F—Fuse Holder - Contains 14 amp fuse.

G—Ammeter - The ammeter indicates the rate of charge (+) or discharge (—) of the battery. When the engine is first started, the ammeter will usually indicate a charge rate of approximately 30 amps. After a short period of operation, the ammeter needle will point slightly to the right of “0”, indicating the charging system is operating normally. A problem with the charging system is indicated if the ammeter needle points to the left of “0” during engine operation.

H—Hour Meter - The hour meter operates when the engine is operating, or when the reset button is manually

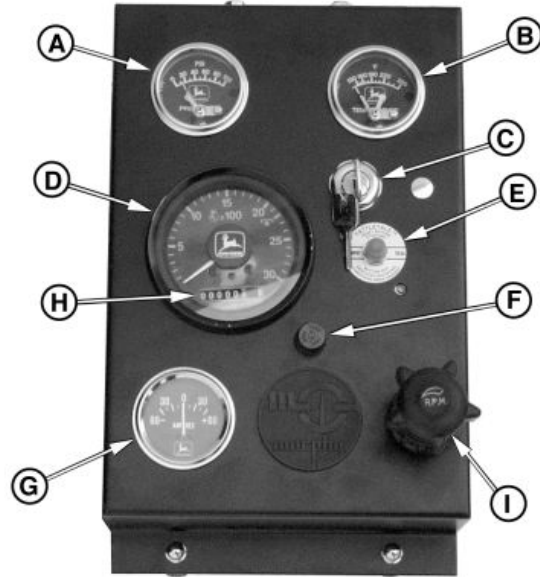

North American Instrument Panel

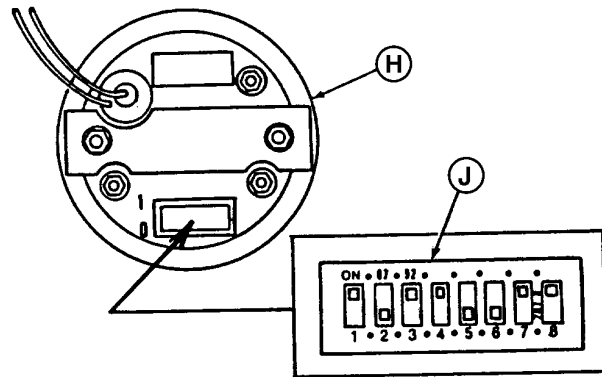

Hour Meter And Tachometer Codes

- | | |
|-----------------------------|-----------------------------|
| A—Oil Pressure Gauge | F—Fuse Holder (14 Amp Fuse) |
| B—Coolant Temperature Gauge | G—Ammeter |
| C—Key Switch | H—Hourmeter |
| D—Tachometer | I—Hand Throttle |
| E—Reset (Safety) Switch | J—Tachometer Binary Code |

held in while the key switch is in the ON position. The accumulated hours are displayed in hours and tenths of hours. On some panels, the hourmeter may be separate from the tachometer.

I—Hand Throttle - The hand throttle is used to manually control engine speed. If the hand throttle is electronic (as shown), turn the knob clockwise or counterclockwise to change engine speed. If the hand throttle is mechanical (not shown), turning the handle, either clockwise or counterclockwise, will lock the throttle position. Turn the handle half way between the two lock positions to unlock the throttle.

Continued on next page

DPSG, RG34710, 108 -19-08JAN02-1/2

RG11299B—UN—17AUG00

RG10607—UN—19OCT99

J—Tachometer Binary Code - The tachometer is calibrated to the number of flywheel gear teeth read. The dip switch to set the binary code is located in back of

tachometer and must be set at “10110011” to operate at 30 pulses per revolution.

DPSG,RG34710,108 -19-08JAN02-2/2

VDO Instrument (Gauge) Panel (Except North America)

All controls and gauges are optional equipment for John Deere OEM Engines. They may be provided by the equipment manufacturer instead of John Deere. The following information applies only to those controls and gauges provided by John Deere.

IMPORTANT: Any time an electric gauge or meter does not register correctly, replace it with a new one. Do not attempt to repair it.

Following is a brief description of the components on the instrument (gauge) panel:

A—Oil Pressure Gauge - The oil pressure gauge indicates engine oil pressure.

B—Coolant Temperature Gauge - The coolant temperature gauge indicates coolant temperature.

C—Tachometer - The tachometer indicates engine speed in hundreds of revolutions per minute (rpm).

The engine control system consists of the following:

D—Engine Control Light - The engine control light illuminates after the engine has started and oil pressure is up to specification. The light indicates that the engine protection circuitry is activated.

E—Preheater Light - The preheater light illuminates when the key is turned to the bulb test position (position I). It should go off after approximately five seconds. When the key switch is held in position II, the engine preheater is energized and the preheater light illuminates.

F—Fuel Level Light - The fuel level light illuminates when the key is turned to the bulb test position (position I). It should go off after approximately five seconds. After the engine is running, if the engine runs out of fuel, the light will illuminate and protection circuitry will stop the engine. The fuel level light will remain on indicating the engine was stopped due to the fuel tank being empty.

G—Battery Light - The battery light illuminates when the key is turned to the bulb test position (position I). It should go off after approximately five seconds. After the engine is running, if the alternator stops charging, the light will illuminate and protection circuitry will stop the engine. The battery light will remain on indicating the engine was stopped due to the alternator not charging.

H—Oil Pressure Light - The oil pressure light illuminates when the key switch is turned to the bulb test position

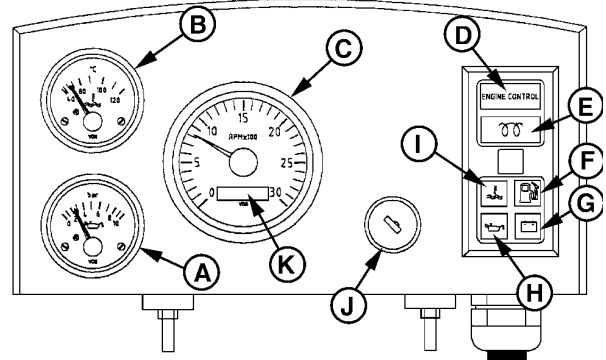

VDO Instrument Panel

- | | |
|------------------------------------|------------------------------------|
| A—Oil Pressure Gauge | G—Battery Light |
| B—Coolant Temperature Gauge | H—Oil Pressure Light |
| C—Tachometer | I—Coolant Temperature Light |
| D—Engine Control Light | J—Key/Start Switch |
| E—Preheater Light | K—Hour Meter |
| F—Fuel Level Light | |

(position I). The light will remain on until the engine is started and the specified oil pressure is reached. If oil pressure is lost during engine operation, the light will illuminate and protection circuitry will stop the engine. The oil pressure light will remain on, indicating that the engine was stopped due to a low oil pressure condition.

I—Coolant Temperature Light - The coolant temperature light illuminates when the key is turned to the bulb test position (position I). It should go off after approximately five seconds. After the engine is running, if the engine overheats, the light will illuminate and protection circuitry will stop the engine. The coolant temperature light will remain on indicating the engine was stopped due to the engine overheating.

Other components on the instrument panel:

J—Key/Start Switch - The four-position key start switch controls the electrical system.

K—Hour Meter - The hour meter is an integral part of the tachometer. It shows the accumulated hours of engine service. The hour meter operates when the engine is running and accumulated hours are displayed in hours and tenths of hours.

DPSG,RG34710,109 -19-08JAN02-1/1

RG10806B—UN—200CT99

Engine Break-In Service

The engine is ready for normal operation. However, extra care during the first 250 hours of operation will result in more satisfactory long-term engine performance and life. DO NOT exceed 250 hours of operation with break-in oil.

1. This engine is factory-filled with John Deere ENGINE BREAK-IN OIL. Operate the engine at heavy loads with minimal idling during the break-in period.
2. If the engine has significant operating time at idle, constant speeds, and/or light load usage, or makeup oil is required in the first 250 hour period, a longer break-in period may be required. In these situations, an additional 250 hour break-in period is recommended using a new change of John Deere ENGINE BREAK-IN OIL and a new John Deere oil filter.



Check Engine Oil

RG8009—UN—06JAN99

OURGP12,0000076 -19-09SEP04-1/4

IMPORTANT: DO NOT add makeup oil until the oil level is BELOW the ADD mark on dipstick. John Deere ENGINE BREAK-IN OIL (TY22041) should be used to make up any oil consumed during the break-in period.

3. Check engine oil level more frequently during engine break-in period. If oil must be added during this period, John Deere ENGINE BREAK-IN OIL is preferred. See ENGINE BREAK-IN OIL, in Fuels, Lubricants, and Coolant Section.

IMPORTANT: DO NOT use PLUS-50® Engine Oil during the break-in period of a new engine or engine that has had a major overhaul. PLUS-50® oil will not allow a new or overhauled engine to properly wear during this break-in period.

DO NOT fill above the crosshatch pattern (A) or the FULL mark, whichever is present. Oil levels anywhere within the crosshatch are considered in the acceptable operating range.

PLUS-50 is a trademark of Deere & Company.

¹At normal operating temperature of 115°C (240°F) sump.

RG8028A—UN—15JAN99

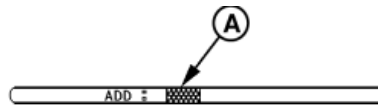

Crosshatch Pattern On Oil Dipstick

A—Crosshatch Pattern On Oil Dipstick

Specification

Engine ¹ —Oil Pressure at Full Load Rated Speed.....	345 ± 103 kPa (3.45 ± 1.03 bar) (50 ± 15 psi)
Minimum Oil Pressure at Rated Speed.....	275 (2.75 bar) (40 psi)
Minimum Oil Pressure at 850 rpm	105 kPa (1.05 bar) (15 psi)
Coolant Temperature Range.....	82°–94°C (180°–202°F)

Continued on next page

OURGP12,0000076 -19-09SEP04-2/4

Engine Operating Guidelines

4. During the first 20 hours, avoid prolonged periods of engine idling or sustained maximum load operation. If engine will idle longer than 5 minutes, stop engine.
5. Before the first 250 hours (maximum), change engine oil and replace engine oil filter. (See CHANGING ENGINE OIL AND REPLACING OIL FILTER in Lubrication and Maintenance/250 Hour/6 Month Section.) Fill crankcase with the normal seasonal viscosity grade oil. (See DIESEL ENGINE OIL, in Fuels, Lubricants, and Coolant Section.)

NOTE: *Some increase in oil consumption may be expected when low viscosity oils are used. Check oil levels more frequently.*

If air temperature is below -10°C (14°F), use an engine block heater.



Changing Oil And Oil Filter Before First 250 Hours

RG7961B —UN—22JAN99

OURGP12.0000076 -19-09SEP04-3/4

6. Watch coolant temperature gauge (A) closely. If coolant temperature rises above 112°C (234°F), reduce load on engine. Unless temperature drops quickly, stop the engine and determine the cause before resuming operation.

NOTE: *When the coolant temperature gauge reads approximately 115°C (239°F), the engine will shutdown automatically, if equipped with safety controls.*

7. Check poly-vee belt for proper alignment and seating in pulley grooves.

A—Coolant Temperature Gauge



North American (1999—) Instrument Panel Shown

RG11299F —UN—17AUG00

OURGP12.0000076 -19-09SEP04-4/4

Auxiliary Gear Drive Limitations

IMPORTANT: When attaching an air compressor, hydraulic pump, or other accessory to be driven by the auxiliary gear drive (A) (engine timing gear train at front of engine), power requirements of the accessory must be limited to values listed below:

- 30 kW (40 hp) Continuous Operation at 2500 rpm
- 37 kW (50 hp) Intermittent Operation at 2500 rpm

A—Auxiliary Gear Drive

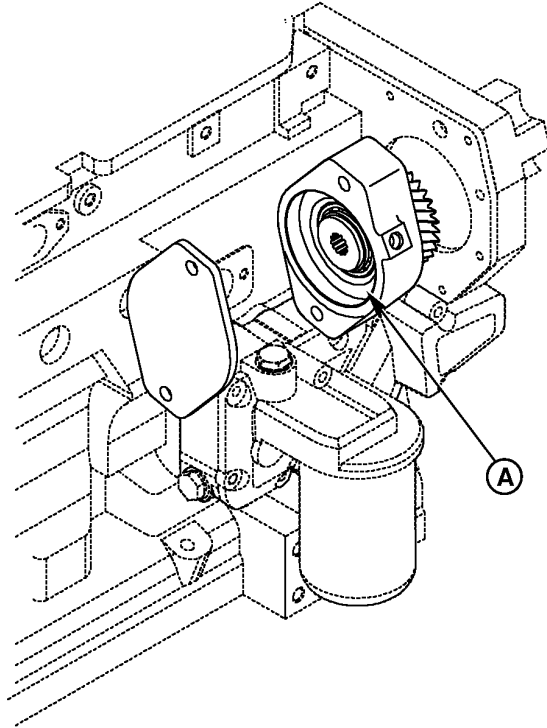

Auxiliary Gear Drive

RG7634A—UN—22JAN99

RG, RG34710, 5555 -19-27JUL06-1/1

Generator Set (Standby) Applications

To assure that your engine will deliver efficient standby operation when needed, start engine and run at rated

speed (with 50%—70% load) for 30 minutes every 2 weeks. DO NOT allow engine to run extended period of time with no load.

RG, RG34710, 5556 -19-27JUL06-1/1

Starting the Engine

The following instructions apply to the optional controls and instruments available through the John Deere Parts Distribution Network. The controls and instruments for your engine may be different from those shown here; always follow manufacturer's instructions.

CAUTION: Before starting engine in a confined building, install proper outlet exhaust ventilation equipment. Always use safety approved fuel storage and piping.

NOTE: If temperature is below 0°C (32°F), it may be necessary to use cold weather starting aids (See COLD WEATHER OPERATION, later in this section).

1. Perform all prestarting checks outlined in Lubrication & Maintenance/Daily Section later in this manual.
2. Open the fuel supply shut-off valve, if equipped.
3. Disengage clutch (if equipped) controlling any engine drivelines.

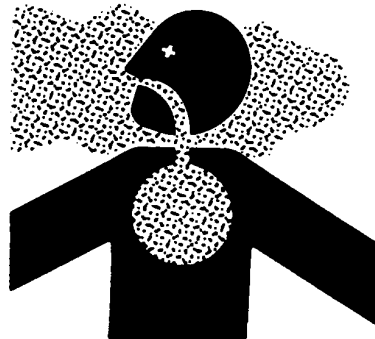

Use Proper Ventilation

NOTE: Electronically controlled governor applications may be equipped with a rotary speed potentiometer on the throttle (A) on the instrument panel.

TS220—UN—15APR13

Continued on next page

RG, RG34710, 5557 -19-07JAN02-1/2

4. On mechanical governor (7-10% regulation) engines, pull hand throttle (A) 1/3 of the way out. Turn the handle in either direction to lock it in place.

5. If equipped, depress and hold reset button (B) while starting.

IMPORTANT: Do not operate the starter for more than 30 seconds at a time. To do so may overheat the starter. If the engine does not start the first time, wait at least 2 minutes before trying again. If engine does not start after four attempts, see Troubleshooting Section.

6. Turn the key switch (C) clockwise to crank the engine. When the engine starts, release the key so that it returns to the "ON" position.

IMPORTANT: If the key switch is released before the engine starts, wait until the starter and the engine stop turning before trying again. This will prevent possible damage to the starter and/or flywheel.

7. After the engine starts, continue to hold the reset button in until the oil pressure gauge (D) reads at least 105 kPa (1.05 bar) (15 psi). The safety controls will not allow the engine to run at a lower oil pressure unless the reset button is held in.

IMPORTANT: Should the engine die when operating under load, immediately disengage PTO clutch and restart the engine. Overheating of turbocharger parts may occur when oil flow is stopped.

8. Check all gauges for normal engine operation. If operation is not normal, stop the engine and determine the cause.

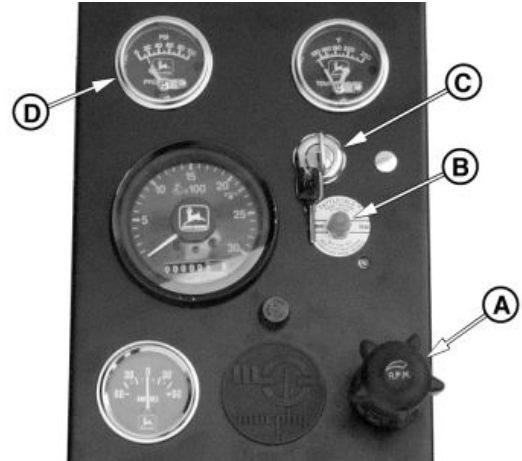

North American Standard Instrument Panel (1999—) Shown

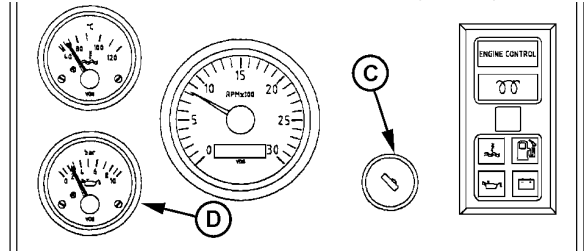

VDO Standard Instrument Panel (Except North America)

A—Hand Throttle
B—Reset Button

C—Key Start Switch
D—Oil Pressure Gauge

RG11298X—UN—18OCT01

RG11610—UN—17OCT01

Warming Engine

IMPORTANT: To assure proper lubrication, operate engine at or below 1200 rpm with no load for 1–2 minutes. Extend this period 2–4 minutes when operating at temperatures below freezing.

Engines used in generator set applications where the governor is locked at a specified speed may not have a slow idle function. Operate these engines at high idle for 1 to 2 minutes before applying the load. This procedure does not apply to standby generator sets where the engine is loaded immediately upon reaching rated speed.

1. Check oil pressure gauge (A) as soon as engine starts. If gauge needle does not rise above minimum oil pressure specification of 105 kPa (1.05 bar) (15.0 psi) within 5 seconds, stop the engine and determine the cause. Normal engine oil pressure is 345 kPa (3.45 bar) (50 psi) at rated full load speed (1800–2500 rpm) with oil at normal operating temperature of 115°C (240°F).

NOTE: On certain engines, the oil pressure and coolant temperature gauges are replaced by indicator warning lights. The lights must be "OFF" when engine is running.

2. Watch coolant temperature gauge (B). Do not place engine under full load until it is properly warmed up. The normal engine coolant temperature range is 82°–94°C (180°–202°F).

NOTE: It is a good practice to operate the engine under a lighter load and at lower speeds than normal for the first few minutes after start-up.

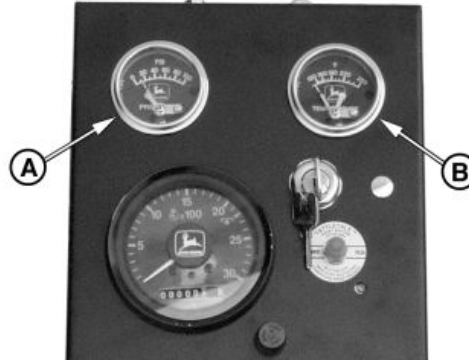

Standard North American Instrument Panel

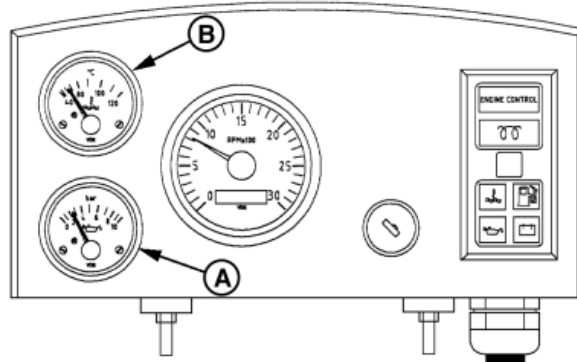

Standard VDO Instrument Panel (Except North America)

A—Oil Pressure Gauge

B—Coolant Temperature Gauge

RG11612—UN—17OCT01

RG10613—UN—21OCT99

RG, RG34710, 5560 -19-08JAN02-1/1

Normal Engine Operation

Observe engine coolant temperature and engine oil pressure. Temperatures and pressures will vary between engines and with changing operating conditions, temperatures, and loads.

Normal engine coolant operating temperature range is 82°–94°C (180°–202°F). If coolant temperature rises above 112°C (234°F), reduce load on engine. Unless temperature drops quickly, stop engine and determine cause before resuming operation.

Operate the engine under a lighter load and at slower than normal speed for first 15 minutes after start-up. DO NOT run engine at slow idle.

IMPORTANT: Should the engine die while operating under load, immediately remove load and restart

the engine. Overheating of the turbocharger parts may occur when oil flow is stopped.

Stop engine immediately if there are any signs of part failure. Symptoms that may be early signs of engine problems are:

- Sudden drop in oil pressure
- Abnormal coolant temperatures
- Unusual noise or vibration
- Sudden loss of power
- Excessive black exhaust
- Excessive fuel consumption
- Excessive oil consumption
- Fluid leaks

RG, RG34710, 5552 -19-20MAY96-1/1

Cold Weather Operation

⚠ CAUTION: Ether injector starting fluid is highly flammable. DO NOT use starting fluid on engines equipped with air intake heaters.

DO NOT use starting fluid near fire, sparks, or flames. DO NOT incinerate or puncture a starting fluid container.

Engines may be equipped with intake air heaters, coolant heaters, or ether injectors as a cold weather starting aid.

Starting aids are required below 32°F (0°C). They will enhance starting performance above these temperatures and may be needed to start applications that have high parasitic loads during cranking and/or start acceleration to idle.

Using correct grade of oil (per engine and machine operator's manual) is critical to achieving adequate cold weather cranking speed.

Other cold weather starting aids are required at temperatures below -22°F (-30°C) or at altitudes above 1500 m (5000 ft).

1. Follow steps 1—4 as listed under , then proceed as follows according to the instrument (gauge) panel on your engine.
2. Switch on the air intake heater for 30 seconds or activate ether injector by following suppliers instructions.
3. Follow remaining steps 5—8 as listed under earlier in this section.

Additional information on cold weather operation is available from your authorized servicing dealer.



Handle Starting Fluid with Care

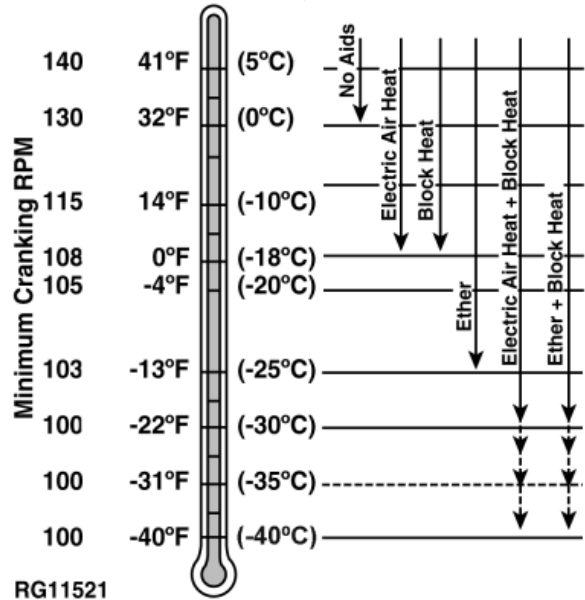

Cold Weather Starting Guidelines

RG11521

RG, RG34710, 5050 -19-08JAN02-1/1

T51356—UN—18MAR92

RG11521—19—10JAN01

Changing Engine Speed

To increase engine speed, turn throttle handle (A), if equipped, to the horizontal position and pull out until desired engine speed is obtained. Turn the handle in either direction to lock throttle position. The handle is pushed inward to decrease engine speed.

NOTE: On engines without handle, use throttle lever to control engine speed.

A—Throttle Handle

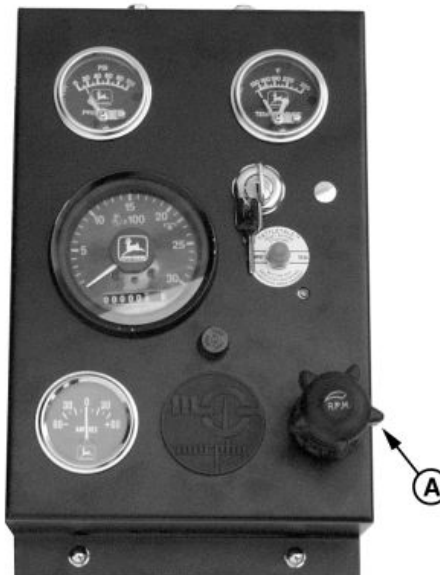

North American Standard Instrument Panel Shown

RG, RG34710, 5561 -19-07JAN02-1/1

RG112991—UN—11SEP00

Avoid Excessive Engine Idling

Prolonged idling may cause the engine coolant temperature to fall below its normal range. This, in turn, causes crankcase oil dilution, due to incomplete fuel combustion, and permits formation of gummy deposits on valves, pistons, and piston rings. It also promotes rapid accumulation of engine sludge and unburned fuel in the exhaust system.

Once an engine is warmed to normal operating temperatures, engine should be idled at slow idle speed.

Slow idle speed for this engine is 850 rpm at factory. If an engine will be idling for more than 5 minutes, stop and restart later.

NOTE: Generator set applications where the governor is locked at a specified speed may not have a slow idle function. These engines will idle at no load governed speed (high idle).

RG, RG34710, 5562 -19-27JUL06-1/1

Stopping the Engine

1. Disengage clutch (if equipped) controlling engine drivelines.
2. Move the throttle (A) to slow idle on standard (mechanical) governor engines.

IMPORTANT: Before stopping an engine that has been operating at working load, idle engine at least 2 minutes at 1000–1200 rpm to cool hot engine parts.

For engines in generator set applications, where the governor is locked at a specified speed and no slow idle function is available, run engine for at least 2 minutes at fast idle and no load.

3. Turn key switch (B) to "OFF" position to stop the engine. Remove ignition key.

IMPORTANT: Make sure that exhaust stack cap (rain cap) is installed when engine is not running. This will prevent water and dirt from entering engine.

A—Throttle

B—Key Switch

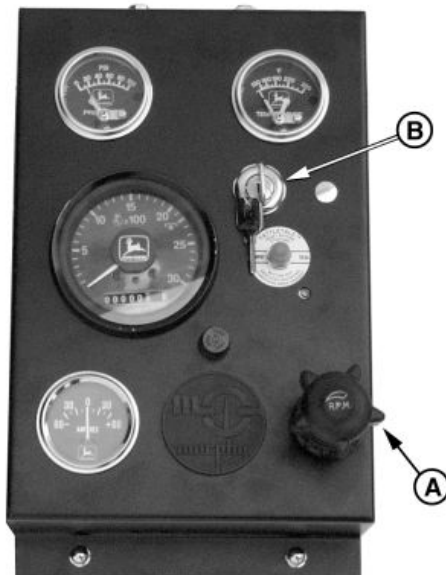

North American Standard Instrument Panel Shown



Exhaust Stack Rain Cap

RG, RG34710, 5563 -19-07JAN02-1/1

RG11299J—UN—11SEP00

RG10616—UN—16JUN00

Using a Booster Battery or Charger

A 12-volt booster battery can be connected in parallel with battery (ies) on the unit to aid in cold weather starting. ALWAYS use heavy duty jumper cables.

CAUTION: Gas given off by battery is explosive. Keep sparks and flames away from battery. Before connecting or disconnecting a battery charger, turn charger off. Make last connection and first disconnection at a point away from battery. Always connect NEGATIVE (-) cable last and disconnect this cable first.

WARNING: Battery posts, terminals, and related accessories contain lead and lead compounds, chemicals known to the State of California to cause cancer and reproductive harm. Wash hands after handling.

IMPORTANT: Be sure polarity is correct before making connections. Reversed polarity will damage electrical system. Always connect positive to positive and negative to ground. Always use 12-volt booster battery for 12-volt electrical systems and 24-volt booster battery (ies) for 24-volt electrical systems.

1. Connect booster battery or batteries to produce the required system voltage for your engine application.

NOTE: To avoid sparks, DO NOT allow the free ends of jumper cables to touch the engine.

2. Connect one end of jumper cable to the POSITIVE (+) post of the booster battery.
3. Connect the other end of the jumper cable to the POSITIVE (+) post of battery connected to starter.
4. Connect one end of the other jumper cable to the NEGATIVE (-) post of the booster battery.
5. ALWAYS complete the hookup by making the last connection of the NEGATIVE (-) cable to a good ground on the engine frame and away from the battery (ies).
6. Start the engine. Disconnect jumper cables immediately after engine starts. Disconnect NEGATIVE (-) cable first.



Exploding Battery

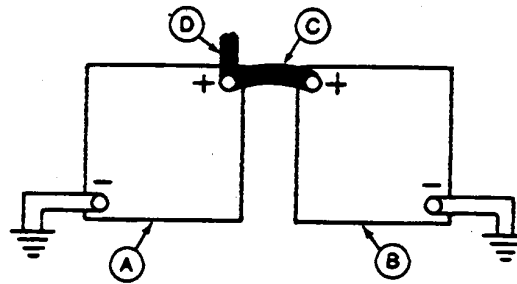

12-Volt System

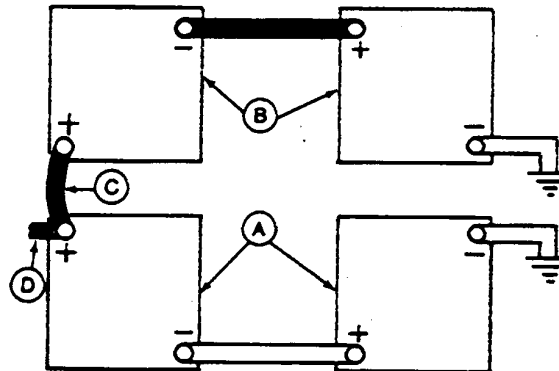

24-Volt System

A—12-Volt Machine Battery (ies)
B—12-Volt Booster Battery (ies)

C—Booster Cable
D—Cable to Starting Motor

RG, RG34710, 5564 -19-27JUL06-1/1

TS204—UN—15APR13

RG4678—UN—14DEC88

RG4698—UN—14DEC88

Lubrication and Maintenance

Required Emission-Related Information

Service Provider

A qualified repair shop or person of the owner's choosing may maintain, replace, or repair emission control devices and systems with original or equivalent replacement parts. However, warranty, recall, and all other services paid for by John Deere must be performed at an authorized John Deere service center.

DX,EMISSIONS,REQINFO -19-12JUN15-1/1

Observe Service Intervals

Using hour meter (A) as guide, perform all services at the hourly intervals indicated on following pages. At each scheduled maintenance interval, perform all previous maintenance operations in addition to the ones specified. Keep a record of hourly intervals and services performed using charts provided in Lubrication and Maintenance Records Section.

IMPORTANT: Recommended service intervals are for normal operating conditions. Service MORE OFTEN if engine is operated under adverse conditions. Neglecting maintenance can result in failures or permanent damage to the engine.

A—Hour Meter

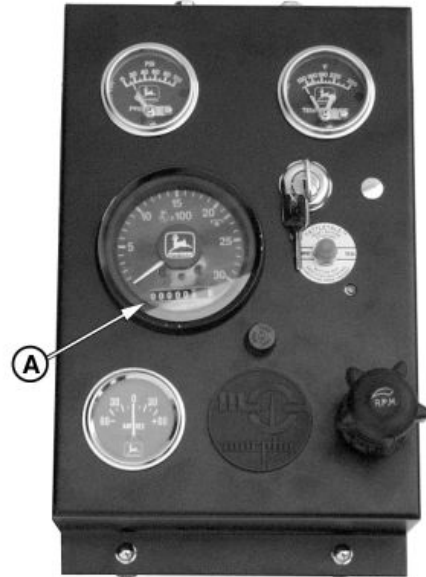

North American Instrument Panel Hour Meter Shown

DPSG,OUOE003,20 -19-07JAN02-1/1

RG11299A—UN—17AUG00

Use Correct Fuels, Lubricants, and Coolant

IMPORTANT: Use only fuels, lubricants, and coolants meeting specifications outlined in Fuels, Lubricants, and Coolant Section when servicing your John Deere Engine.

Consult your John Deere engine distributor, servicing dealer or your nearest John Deere Parts Network for recommended fuels, lubricants, and coolant. Also available are necessary additives for use when operating engines in tropical, arctic, or any other adverse conditions.



DPSG,OUOE003,20 -19-09OCT07-1/1

TS100—UN—23AUG88

Lubrication and Maintenance Service Interval Chart

Item	Lubrication and Maintenance Service Intervals				
	Daily ^a	250 Hour/ 6 Month	500 Hour/ 12 Month	2000 Hour/ 24 Month	As Required
Check Engine Oil and Coolant Level	•				
Check Fuel Filter(s)/Water Separator Bowl	•				
Check Air Cleaner Dust Unloader Valve & Indicator ^b	•				
Perform Visual Walkaround Inspection	•				
Service Fire Extinguisher		•			
Change Engine Oil And Replace Oil Filter ^{c, d}		•			
Check Engine Mounts		•			
Service Battery		•			
Check Manual Belt Tensioner and Belt Wear		•			
Check Automatic Belt Tensioner and Belt Wear			•		
Clean Crankcase Vent Tube			•		
Check Air Intake Hoses, Connections, & System			•		
Replace Single or Dual Fuel Filter Elements			•		
Check Engine Speeds			•		
Check Engine Electrical Ground Connection			•		
Coolant Solution Analysis-Add SCAs as required			•		
Pressure Test Cooling System			•		
Check Cooling System			•		
Test Thermostats				•	
Check Crankshaft Vibration Damper (6.8 L Engines) ^e				•	
Flush Cooling System ^f				•	
Check and Adjust Engine Valve Clearance				•	
Check Variable Speed (Droop) (Genset Only)				•	
Add Coolant					•
Replace Air Cleaner Elements					•
Replace Poly-Vee Belt					•
Check Fuses					•
Check Air Compressor (If Equipped)					•
Bleed Fuel System					•

^aStandby generator applications may allow intervals up to every 2 weeks.

^bReplace primary air cleaner element when restriction indicator shows a vacuum of 625 mm (25 in) H₂O.

^cDuring engine break in, change the oil and filter for the first time before 100 hours of operation.

^dService intervals depend on sulfur content of the diesel fuel, oil pan capacity, and the oil and filter used, which means that intervals may be REDUCED. (See DIESEL ENGINE OIL AND FILTER SERVICE INTERVALS in Fuels, Lubricants, and Coolant Section.)

^eReplace crankshaft damper every 4500 hours or 60 months, whichever occurs first.

^fIf John Deere Cool-Gard is used, the flushing interval may be extended to 3000 hours or 36 months. If John Deere Cool-Gard is used and the coolant is tested annually AND additives are replenished as needed by adding a supplemental coolant additive, the flushing interval may be extended to 5000 hours or 60 months, whichever occurs first.

Lubrication & Maintenance — Daily

Daily Prestarting Checks

Do the following BEFORE STARTING THE ENGINE for the first time each day:

IMPORTANT: DO NOT add makeup oil until the oil level is **BELOW** the add mark.

- A—Left Side Oil Filler Cap
- B—Right Side Oil Filler Cap
- C—Cover Oil Filler Cap
- D—Crosshatch On Dipstick

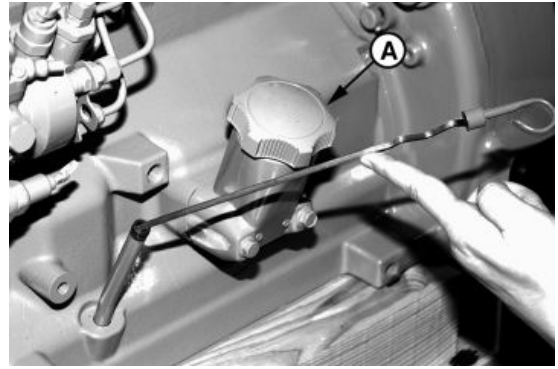

Left Side Oil Filler Cap

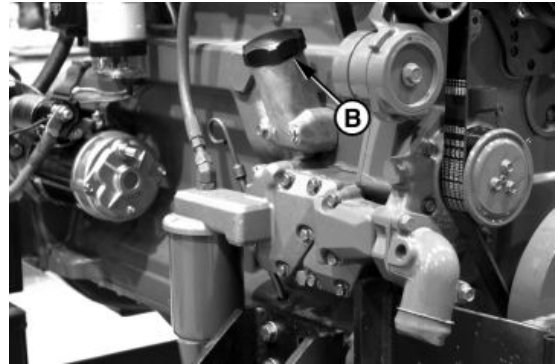

Right Side Oil Filler Cap

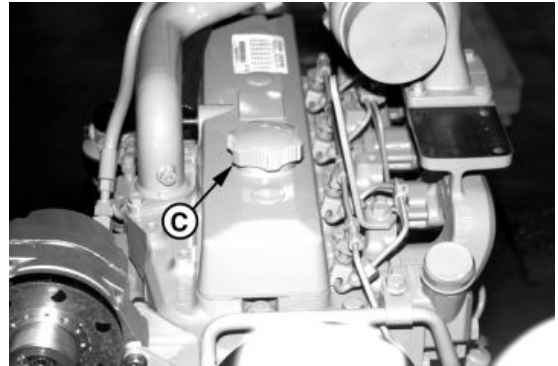

Rocker Arm Cover Filler Cap

RG8028B —UN—15JAN99

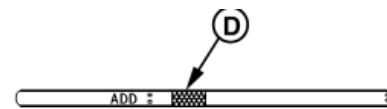

Crosshatch on Dipstick

Continued on next page

OURGP12.0000048 -19-13OCT06-1/4

RG8009A —UN—16JUN00

RG8054A —UN—16JUN00

RG8025B —UN—16JUN00

1. Check engine oil level on dipstick. Add as required, using seasonal viscosity grade oil. (See DIESEL ENGINE OIL in Fuels, Lubricants, and Coolant Section for oil specifications.)

Depending on application, oil may be added at left (A) or right (B) side oil filler cap and rocker arm cover filler cap (C) locations.

IMPORTANT: DO NOT fill above the top mark on the dipstick. Oil levels anywhere within crosshatch (D) are considered in the acceptable operating range.

⚠ CAUTION: Explosive release of fluids from pressurized cooling system can cause serious burns.

Only remove filler cap when engine is cold or when cool enough to touch with bare hands. Slowly loosen cap to first stop to relieve pressure before removing completely.

2. Check the coolant level when engine is cold. Coolant level should be at bottom of filler neck. Fill radiator (A) with proper coolant solution if level is low. (See ADDING COOLANT in Service As Required Section.) Check overall cooling system for leaks.

NOTE: Refer to your vehicle's operator's manual for recommendations for non-John Deere supplied accessories.



High-Pressure Fluids

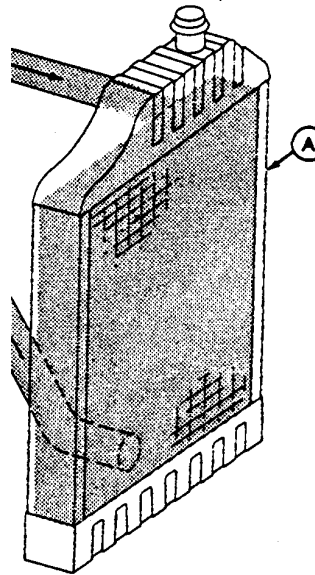

Fill Radiator

A—Fill Radiator

TSS281 —UN—15APR13

RG4675 —UN—14DEC88

Continued on next page

OURGP12,0000048 -19-13OCT06-2/4

3. Check the single or dual fuel filters for water or debris. If filter is fitted with a see-through water separator bowl, drain as needed based on a daily visual inspection.

IMPORTANT: Drain water into a suitable container and dispose of properly.

- a. Loosen drain plugs (B) at bottom of each fuel filter or bowl, if equipped, two or three turns.
- b. Loosen air bleed plugs (A) two full turns on fuel filter mountings and drain water from bottom until fuel starts to drain out.
- c. When fuel starts to drain out, tighten drain plugs securely.

After draining water from the fuel filter, the filter must be primed by bleeding all air from the fuel system.

- a. Operate primer lever of the fuel supply pump (C) until fuel flow is free from air bubbles.
- b. Tighten bleed plugs securely, and continue operating hand primer until pumping action is not felt. Primer lever is spring-loaded, and will return to normal position.

If the fuel system needs further bleeding of air, see BLEEDING FUEL SYSTEM in Service As Required Section, later in this manual.

A—Air Bleed Plugs
B—Drain Plugs

**C—Fuel Supply Pump Primer
Lever**

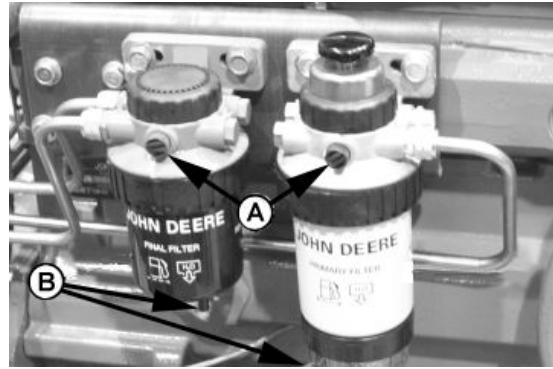

Drain Fuel Filters (Dual Filters Shown)

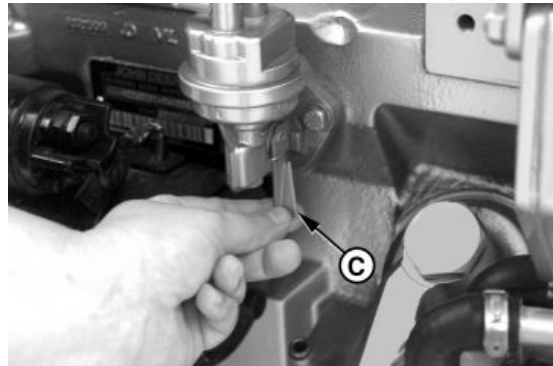

Priming At Fuel Supply Pump

Continued on next page

OURGP12.0000048 -19-13OCT06-3/4

RG13542 —UN—20JUL04

RG7317A —UN—16JUN00

- If the air cleaner has an automatic dust unloader valve (A), squeeze the unloader valve on air cleaner assembly to clear away any dust buildup.

If equipped with air intake restriction indicator gauge (B), check gauge to determine if air cleaner needs to be serviced.

IMPORTANT: Maximum air intake restriction is 6.25 kPa (0.06 bar) (1.0 psi) (25 in. H²O). A clogged air cleaner element will cause excessive intake restriction and a reduced air supply to the engine.

- Make a thorough inspection of the engine compartment. Look for oil or coolant leaks, worn fan and accessory drive belts, loose connections and trash build-up. Remove trash buildup and have repairs made as needed if leaks are found.

NOTE: Wipe all fittings, caps, and plugs before performing any maintenance to reduce the chance of system contamination.

Inspect:

- Radiator for leaks and trash build-up.
- Air intake system hoses and connections for cracks and loose clamps.
- Fan, alternator, and accessory drive belts for cracks, breaks or other damage.

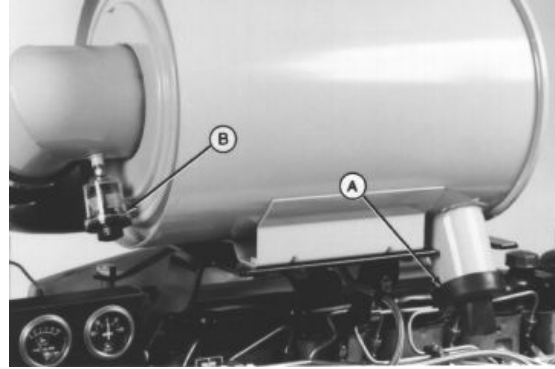

Dust Unloader Valve and Indicator Gauge

A—Dust Unloader Valve

B—Air Restriction Indicator

- Water pump for coolant leaks.

NOTE: It is normal for a small amount of leakage to occur as the engine cools down and parts contract. Excessive coolant leakage may indicate the need to replace the water pump seal. Contact your engine distributor or servicing dealer for repairs.

RG7332A—UN—22JAN99

OURGP12,0000048 -19-13OCT06-4/4

Lubrication & Maintenance — 250 Hours/6 Months

Servicing Fire Extinguisher

A fire extinguisher (A) is available from your authorized servicing dealer or engine distributor.

Read and follow the instructions which are packaged with it. The extinguisher should be inspected at least every 250 hours of engine operation or once a month. Once extinguisher is operated, no matter how long, it must be recharged. Keep record of inspections on the tag which comes with the extinguisher instruction booklet.

A—Fire Extinguisher



Fire Extinguisher

RG.RG34710,5567 -19-20MAY96-1/1

RW4918 —UN—15DEC88

Changing Engine Oil and Replacing Filter

NOTE: Change engine oil and oil filter for the first time after 100 hours maximum of operation, then every 250 hours thereafter.

If John Deere PLUS-50® or ACEA E4 or E5 engine oil **and** a John Deere oil filter are used, the oil and filter change interval may be extended by 50 percent.

OILSCAN® or OILSCAN PLUS® is a John Deere sampling program to help you monitor machine performance and identify potential problems before they cause serious damage. OILSCAN® and OILSCAN PLUS® kits are available from your John Deere engine distributor or servicing dealer. Oil samples should be taken prior to the oil change. Refer to instructions provided with kit.

To change engine oil and oil filter:

1. Run engine approximately 5 minutes to warm up oil. Shut engine off.
2. Remove oil pan drain plug (arrow).
3. Drain crankcase oil from engine while warm.

NOTE: Drain plug location may vary, depending on the application.

A—Oil Filter Element

*PLUS-50 is a trademark of Deere & Company.
OILSCAN is a trademark of Deere & Company.
OILSCAN PLUS is a trademark of Deere & Company.*



Oil Filter



Oil Pan Drain Plug

Continued on next page

OURGP12,0000078 -19-31OCT06-1/3

RG11616 —UN—24OCT01

RG4881 —UN—29NOV88

- Turn filter element (A) counterclockwise using a suitable filter wrench to remove. Discard oil filter element.

NOTE: Depending on engine application, oil filter may be located on either side of the engine.

- Remove oil filter packing and clean filter mounting pad.

IMPORTANT: Filtration of oils is critical to proper lubrication. Always change filter regularly. Use filter meeting John Deere performance specifications.

- Oil new packing and install new filter element. Hand tighten element according to values printed on filter element. If values are not provided, tighten element approximately 3/4 — 1-1/4 turn after packing contacts filter housing. **DO NOT** overtighten filter element.
- Install oil pan drain plug with O-ring or copper washer. If copper washer is used, install with raised center against plug. If O-ring or washer is damaged, replace it.
- Tighten drain plug to specifications.

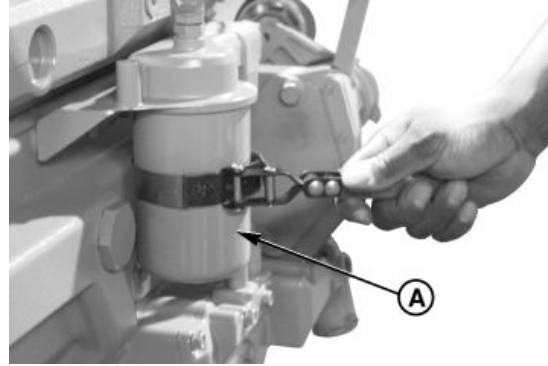

Removing Oil Filter Element

A—Oil Filter Element

Specification

Oil Pan Drain Plug With Copper Washer—Torque.....	70 N·m (52 lb ft)
Oil Pan Drain Plug With O-Ring—Torque.....	50 N·m (37 lb ft)

OURGP12,0000078 -19-31OCT06-2/3

RG7961A—UN—22JAN99

- Fill engine crankcase with correct John Deere engine oil through rocker arm cover opening (B) or either side oil filler (C) depending on engine application. (See DIESEL ENGINE OIL in Fuels, Lubricants, and Coolant Section for determining correct engine oil.)

To determine the correct oil fill quantity for your engine, see ENGINE CRANKCASE OIL FILL QUANTITIES in the Specifications Section of this manual.

IMPORTANT: Immediately after completing any oil change, crank engine for 30 seconds without permitting engine to start. This will help insure adequate lubrication to engine components before engine starts.

NOTE: Crankcase oil capacity may vary slightly. ALWAYS fill crankcase to full mark or within crosshatch on dipstick, whichever is present. DO NOT overfill.

- Start engine and run to check for possible leaks.
- Stop engine and check oil level after 10 minutes. Oil level reading should be within crosshatch of dipstick.

B—Rocker Arm Cover Oil Filler C—Side Oil Filler

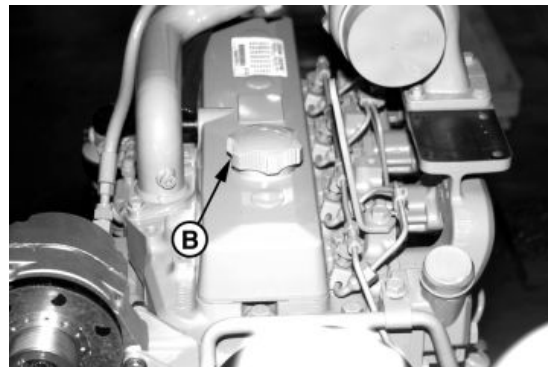

Rocker Arm Cover Oil Filler

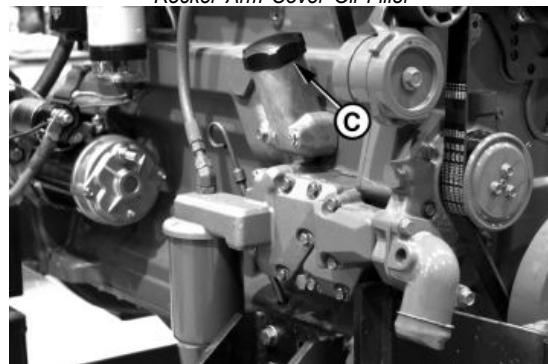

Side Oil Filler

OURGP12,0000078 -19-31OCT06-3/3

RG8025A—UN—16JUN00

RG8054B—UN—19JUN00

Checking Engine Mounts

Engine mounting is the responsibility of the vehicle or generator manufacturer. Follow manufacturer's guidelines for mounting specifications.

IMPORTANT: Use only Grade SAE 8 or higher grade of hardware for engine mounting.

1. Check the engine mounting bracket, vibration isolators, and mounting bolts on support frame and engine block for tightness. Tighten as necessary.
2. Inspect overall condition of vibration isolators, if equipped. Replace isolators if rubber has deteriorated or mounts have collapsed, as necessary.

DPSG, RG34710, 111 -19-07, JAN02-1/1

Servicing Battery

⚠ CAUTION: Battery gas can explode. Keep sparks and flames away from batteries. Use a flashlight to check battery electrolyte level.

Never check battery charge by placing a metal object across the posts. Use a voltmeter or hydrometer.

Always remove grounded NEGATIVE (-) battery clamp first and replace it last.

WARNING: Battery posts, terminals, and related accessories contain lead and lead compounds, chemicals known to the State of California to cause cancer and reproductive harm. **Wash hands after handling.**

1. On regular batteries, check electrolyte level. Fill each cell to bottom of filler neck with distilled water.

NOTE: Low-maintenance or maintenance-free batteries should require little additional service. However, electrolyte level can be checked by cutting the center section of decal on dash-line, and removing cell plugs. If necessary, add clean, soft water to bring level to bottom of filler neck.

2. Keep batteries clean by wiping them with a damp cloth. Keep all connections clean and tight. Remove



Exploding Battery

any corrosion, and wash terminals with a solution of 1 part baking soda and 4 parts water. Tighten all connections securely.

NOTE: Coat battery terminals and connectors with a mixture of petroleum jelly and baking soda to retard corrosion.

3. Keep battery fully charged, especially during cold weather. If a battery charger is used, turn charger off before connecting charger to battery(ies). Attach POSITIVE (+) battery charger lead to POSITIVE (+) battery post. Then attach NEGATIVE (-) battery charger lead to a good ground.

Continued on next page

RG, RG34710, 5568 -19-27, JUL06-1/2

TS204 —UN—15APR13

CAUTION: Sulfuric acid in battery electrolyte is poisonous. It is strong enough to burn skin, eat holes in clothing, and cause blindness if splashed into eyes.

Avoid the hazard by:

1. Filling batteries in a well-ventilated area.
2. Wearing eye protection and rubber gloves.
3. Avoiding breathing fumes when electrolyte is added.
4. Avoiding spilling or dripping electrolyte.
5. Use proper jump start procedure.

If you spill acid on yourself:

1. Flush your skin with water.
2. Apply baking soda or lime to help neutralize the acid.
3. Flush your eyes with water for 10–15 minutes. Get medical attention immediately.

If acid is swallowed:

1. Drink large amounts of water or milk.
2. Then drink milk of magnesia, beaten eggs, or vegetable oil.
3. Get medical attention immediately.

In freezing weather, run engine at least 30 minutes to assure thorough mixing after adding water to battery.

If necessary to replace battery(ies), replacements must meet or exceed the following recommended capacities at -18°C (0°F):

Specification	
12 Volt Standard Duty Starter—Cold Cranking	
Amps.....	640
12 Volt Heavy Duty Starter—Cold Cranking	
Amps.....	800

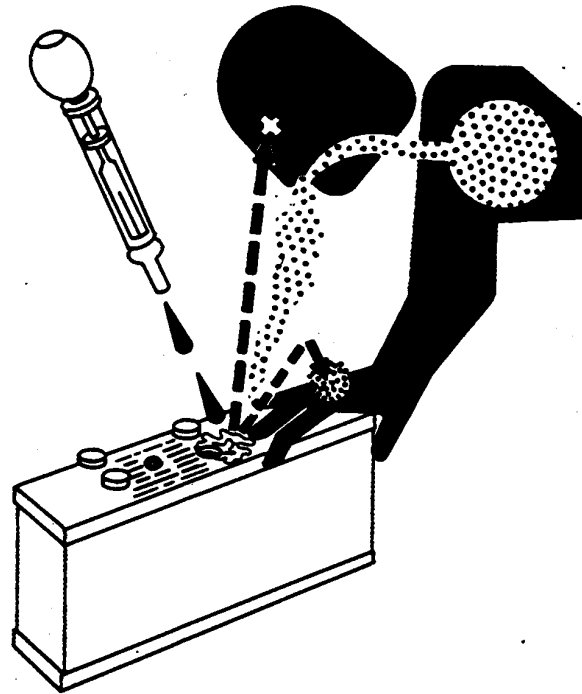

Sulfuric Acid

24 Volt Standard Duty Starter—Cold Cranking	
Amps.....	570

TS203—UN—23AUG88

RG, RG34710, 5568 -19-27JUL06-2/2

Manual Belt Tensioner Adjustment

NOTE: Two types of manual tensioners shown.

NOTE: Inspect belts for cracks, fraying, or stretched-out areas. Replace if necessary.

As a reference check, twist belt in the middle of a 254—305 mm (10—12 in.) span with two fingers. A properly tensioned belt will turn 75—85 degrees. If belt turns more, it needs to be tightened. If belt turns less, it needs to be loosened.

NOTE: If timing gear cover or alternator bracket interfere with installation/centering of belt tension gauge (A), install gauge with face toward engine.

1. Install JDG1341 Belt Tension Gauge (A) on belt, halfway between pulleys as shown. (JDG1341 Belt Tension Gauge available from local John Deere Dealer or Distributor.)
2. Loosen cap screws (B) and (C).
3. Slide alternator or tensioner bracket (D) in slot by hand to remove all excess slack in belt.

IMPORTANT: Do not pry against alternator rear frame.

4. Stretch belt by prying outward on alternator front frame or tensioner bracket. Observing tension gauge, stretch the belt until specified tension is achieved.

Specification

New Belt—Tension..... 470—650 N (105—145 lb-force)
 Used Belt—Tension..... 400—580 N (90—130 lb-force)

5. Tighten cap screws (B) and (C).

NOTE: After ten minutes run-in, new belts are considered used. Belt tension must then be rechecked per used belt specifications.

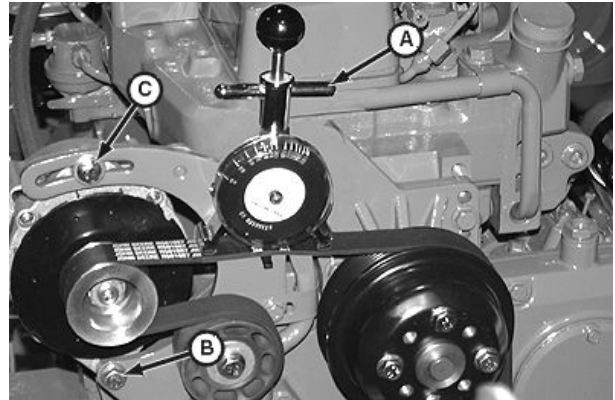

Check Belt Tension

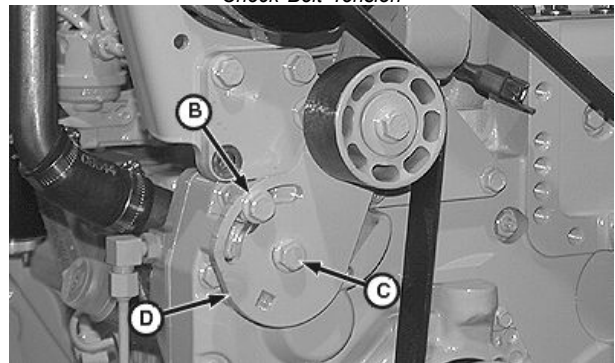

Adjust Belt Tension

A—Belt Tension Gauge
 B—Cap Screw

C—Cap Screw
 D—Tensioner Bracket

6. Run engine for ten minutes and immediately re-check belt tension per used belt specification above.
7. Reset belt tension as necessary.

OURGP11,000008 -19-24JUN04-1/1

RG10556 —UN—21DEC99

RG10557 —UN—21DEC99

Manual Belt Tensioner Adjustment Using Belt Tension Tool (Alternate Method For Engines Without Auxiliary Drive)

NOTE: The JDG1520 Belt Tension Tool may not be compatible with all alternators. In that case, use the preceding method for belt tensioning.

NOTE: Inspect belts for cracks, fraying, or stretched-out areas. Replace if necessary.

As a reference check, twist belt in the middle of a 254—305 mm (10—12 in.) span with two fingers. A properly tensioned belt will turn 75—85 degrees. If belt turns more, it needs to be tightened. If belt turns less, it needs to be loosened.

1. Loosen upper (A) and lower (B) alternator bracket cap screws. Lower cap screw must remain tight enough to prevent excessive alternator play but allow alternator to pivot by hand.
2. Insert JDG1520 Belt Tension Tool (C) behind belt (D) and over alternator mounting screw.

A—Upper Alternator Bracket Cap Screw

B—Lower Alternator Bracket Cap Screw

C—JDG1520 Belt Tension Tool

D—Belt

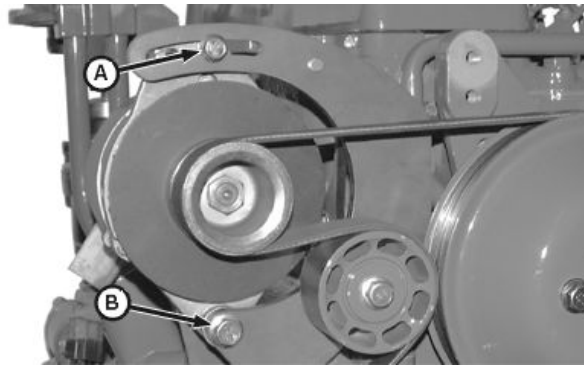

Alternator Bracket and Cap Screws

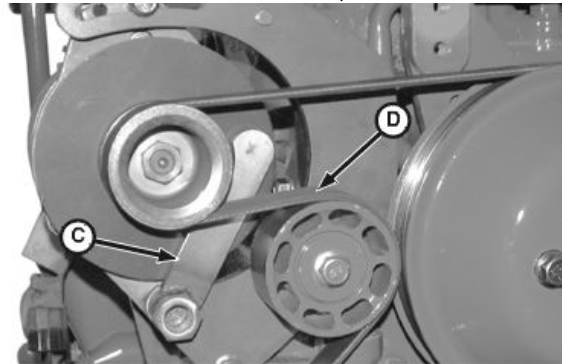

Belt Tension Tool

RG11812—UN—31OCT01

RG11813—UN—31OCT01

Continued on next page

OURGP11,0000009 -19-24JUN04-1/2

Lubrication & Maintenance — 500 Hours/12 Months

Cleaning Crankcase Vent Tube

If you operate the engine in dusty conditions, clean the tube at shorter intervals.

1. Remove and clean crankcase vent tube (A).
2. Install the vent tube. Be sure the O-ring fits correctly in the rocker arm cover for elbow adapter. Tighten hose clamp securely.

A—Crankcase Vent Tube

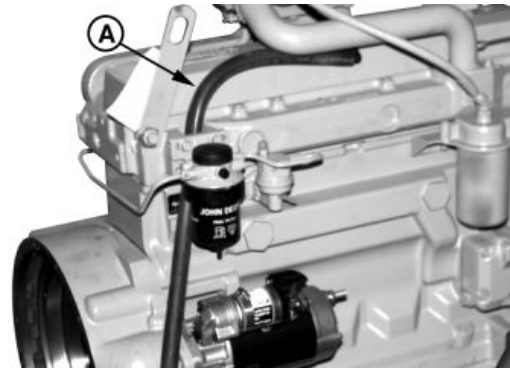

Crankcase Vent Tube

RG, RG34710, 5574 -19-08JAN02-1/1

RG8017A —JUN—19JUN00

Checking Air Intake System

IMPORTANT: The air intake system must not leak. Any leak, no matter how small, may result in internal engine damage due to abrasive dirt and dust entering the intake system.

1. Inspect all intake hoses (piping) for cracks. Replace as necessary.
2. Check clamps (A) on piping which connect the air cleaner, engine and, if present, turbocharger. Tighten clamps as necessary. This will help prevent dirt from entering the air intake system through loose connections causing internal engine damage.
3. If engine has a rubber dust unloader valve (B), inspect the valve on bottom of air cleaner for cracks or plugging. Replace as necessary.

IMPORTANT: ALWAYS REPLACE primary air cleaner element when air restriction indicator shows a vacuum of 625 mm (25 in.) H₂O, is torn, or visibly dirty.

4. Test air restriction indicator (C) for proper operation. Replace indicator as necessary.

IMPORTANT: If not equipped with air restriction indicator, replace air cleaner elements at 500 Hours or 12 Months, whichever occurs first.

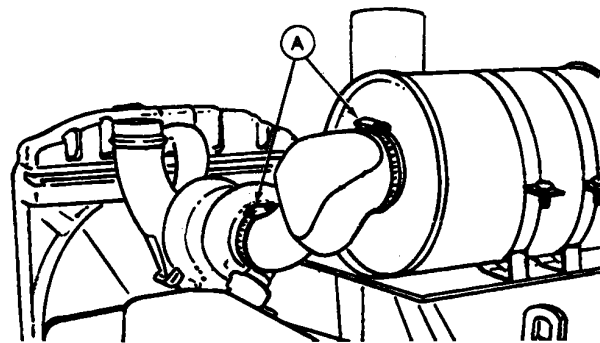

Check Clamps

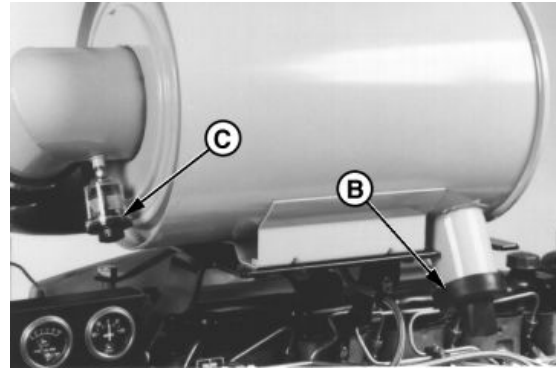

Unloader Valve and Air Restriction Indicator

A—Clamps
B—Dust Unloader Valve

C—Air Restriction Indicator

RG, RG34710, 5575 -19-07JAN02-1/1

RG4689 —JUN—20DEC88

RG7332B —JUN—22JAN99

Replacing Fuel Filter Element (Single Filter)

CAUTION: Escaping fluid under pressure can penetrate the skin causing serious injury. Relieve pressure before disconnecting fuel or other lines. Tighten all connections before applying pressure. Keep hands and body away from pinholes and nozzles which eject fluids under high pressure. Use a piece of cardboard or paper to search for leaks. Do not use your hand.

If any fluid is injected into the skin, it must be surgically removed within a few hours by a doctor familiar with this type injury or gangrene may result. Doctors unfamiliar with this type of injury may call the Deere & Company Medical Department in Moline, Illinois, or other knowledgeable medical source.

1. Close fuel shut-off valve, if equipped.
2. Thoroughly clean fuel filter assembly and surrounding area.
3. Loosen drain plug (C) and drain fuel into a suitable container.

NOTE: Lifting up on retaining ring as it is rotated helps to get it past raised locators.

4. Firmly grasp the retaining ring (A) and rotate it clockwise 1/4 turn (when viewed from top). Remove ring with filter element (B).
5. Inspect filter mounting base for cleanliness. Clean as required.

NOTE: Raised locators on fuel filter canister must be indexed properly with slots in mounting base for correct installation.

6. Install new filter element onto mounting base. Be sure element is properly indexed and firmly seated on base. It may be necessary to rotate filter for correct alignment.
7. Align keys on filter element with slots in filter base.
8. Install retaining ring onto mounting base making certain dust seal is in place on filter base. Hand tighten

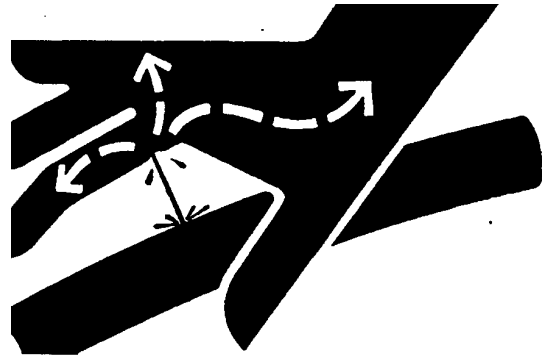

High-Pressure Fluids

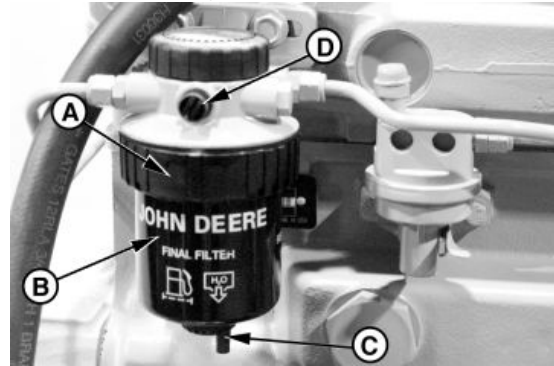

Fuel Filter

A—Retaining Ring
B—Filter Element

C—Drain Plug
D—Bleed Plug

ring (about 1/3 turn) until it “snaps” into the detent. DO NOT overtighten retaining ring.

NOTE: The proper installation is indicated when a “click” is heard and a release of the retaining ring is felt.

A plug is provided with the new element for plugging the used element.

9. Open fuel shut-off valve and bleed the fuel system. (See BLEEDING FUEL SYSTEM in Service As Required Section.) Tighten bleed plug (D).

OURGP11,000000A -19-24JUN04-1/1

X9811—UN—23AUG88

RG7721—UN—15JAN89

Replacing Fuel Filter Elements (Dual Filters)

CAUTION: Escaping fluid under pressure can penetrate the skin causing serious injury. Relieve pressure before disconnecting fuel or other lines. Tighten all connections before applying pressure. Keep hands and body away from pinholes and nozzles which eject fluids under high pressure. Use a piece of cardboard or paper to search for leaks. Do not use your hand.

If any fluid is injected into the skin, it must be surgically removed within a few hours by a doctor familiar with this type injury or gangrene may result. Doctors unfamiliar with this type of injury may call the Deere & Company Medical Department in Moline, Illinois, or other knowledgeable medical source.

1. Close fuel shut-off valve, if equipped.
2. Thoroughly clean fuel filter assemblies and surrounding area.

NOTE: Perform the following steps on each fuel filter.

3. Loosen drain plug (C) and drain fuel into a suitable container.

NOTE: Lifting up on retaining ring as it is rotated helps to get it past raised locators.

4. Firmly grasp the retaining ring (A) and rotate it clockwise 1/4 turn (when viewed from top). Remove ring with filter element (B).
5. Inspect filter mounting base for cleanliness. Clean as required.
6. On primary filter with water separator, remove filter element from water separator bowl. Drain and clean separator bowl. Dry with compressed air. Install water separator bowl onto new element. Tighten securely.

NOTE: Raised locators on fuel filter canister must be indexed properly with slots in mounting base for correct installation.

7. Install new filter element onto mounting base. Be sure element is properly indexed and firmly seated on base. It may be necessary to rotate filter for correct alignment.
8. Align keys on filter element with slots in filter base.

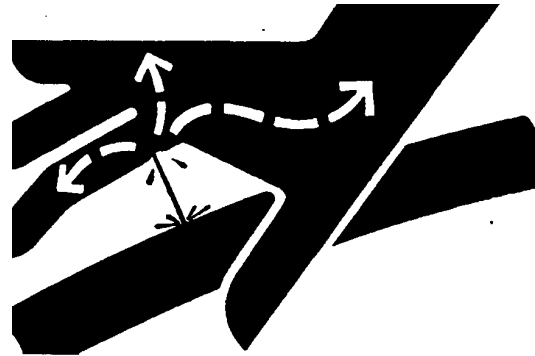

High-Pressure Fluids

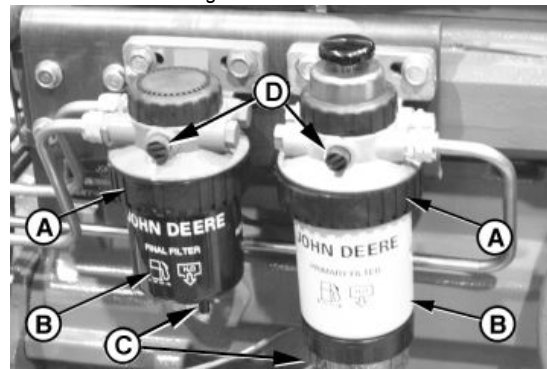

Dual Fuel Filters (Final Filter at Left, Primary Filter with Bowl at Right)

A—Retaining Ring
B—Filter Element

C—Drain Plug
D—Bleed Plug

9. Install retaining ring onto mounting base making certain dust seal is in place on filter base. Hand tighten ring (about 1/3 turn) until it “snaps” into the detent. DO NOT overtighten retaining ring.

NOTE: The proper installation is indicated when a “click” is heard and a release of the retaining ring is felt.

A plug is provided with the new element for plugging the used element.

10. Open fuel shut-off valve and bleed the fuel system. (See BLEEDING FUEL SYSTEM in Service As Required Section.) Tighten bleed plug (D).

OURGP12,000004B -19-13OCT06-1/1

X9811 —UN—23AUG88

RG13543 —UN—21JUL04

Checking Belt Tensioner Spring Tension and Belt Wear (Automatic Tensioner)

Belt drive systems equipped with automatic (spring) belt tensioners cannot be adjusted or repaired. The automatic belt tensioner is designed to maintain proper belt tension over the life of the belt. If tensioner spring tension is not within specification, replace tensioner assembly.

Checking Belt Wear

The belt tensioner is designed to operate within the limit of arm movement provided by the cast stops (A and B) when correct belt length and geometry is used.

Visually inspect cast stops (A and B) on belt tensioner assembly.

If the tensioner stop on swing arm (A) is hitting the fixed stop (B), check mounting brackets (alternator, belt tensioner, idler pulley, etc.) and the belt length. Replace belt as needed (see REPLACING FAN AND ALTERNATOR BELTS in Service As Required Section).

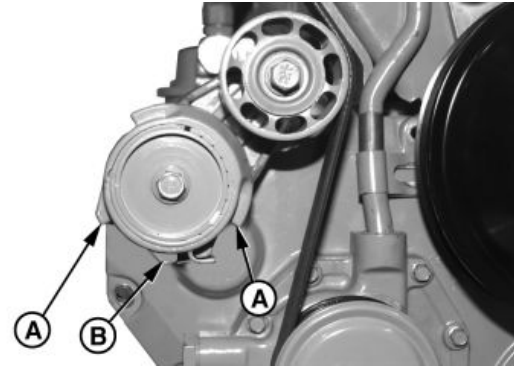

Cast Stops

A—Cast Stops

B—Cast Stop

Continued on next page

OURGP12,000004A -19-28JUL04-1/2

RG8098—UN—18NOV97

Checking Tensioner Spring Tension

A belt tension gauge will not give an accurate measure of the belt tension when automatic spring tensioner is used. Measure tensioner spring tension using a torque wrench and procedure outlined below:

NOTE: Later engines have a 12.7 mm (1/2 in.) square drive hole in tensioner, so no socket drive is required.

1. Release tension on belt using a breaker bar and socket (if required) on tension arm. Remove belt from pulleys.
2. Release tension on tension arm and remove breaker bar.
3. Put a mark (A) on swing arm of tensioner as shown.
4. Measure 21 mm (0.83 in.) from (A) and put a mark (B) on tensioner mounting base.
5. Install torque wrench (C) so that it is aligned with center of pulley and tensioner. Rotate the swing arm with the torque wrench until marks (A and B) are aligned.
6. Record torque wrench measurement and compare with specification below. Replace tensioner assembly as required.

Specification

Spring Tension—Torque..... 18-22 N·m (13-16 lb-ft)

NOTE: Threads on earlier belt tensioner roller cap screw are LEFT-HAND threads.

A—Mark On Swing Arm
B—Mark On Tensioner
Mounting Base

C—Torque Wrench

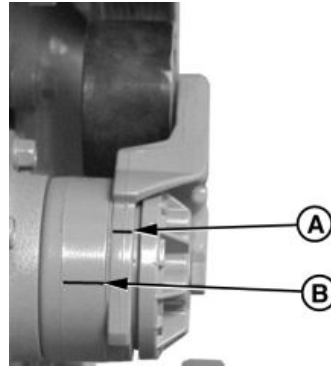

Marks on Tensioner

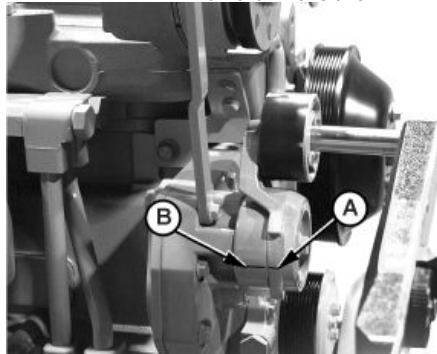

Align Marks

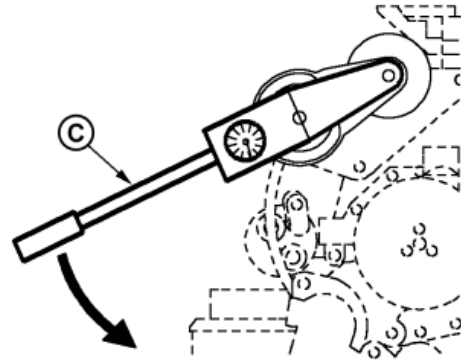

Align Torque Wrench With Pulley And Tensioner

RG7977—UN—14NOV97

RG12054—UN—08JAN02

RG12065—UN—28JAN02

OURGP12,000004A -19-28JUL04-2/2

Checking Engine Speeds

Observe tachometer (A) reading on the instrument panel to verify engine speeds while running engine. (Refer to Specifications section later in this manual for engine speed specifications.) If engine speeds need adjustment, contact your engine dealer or distributor.

A—Tachometer

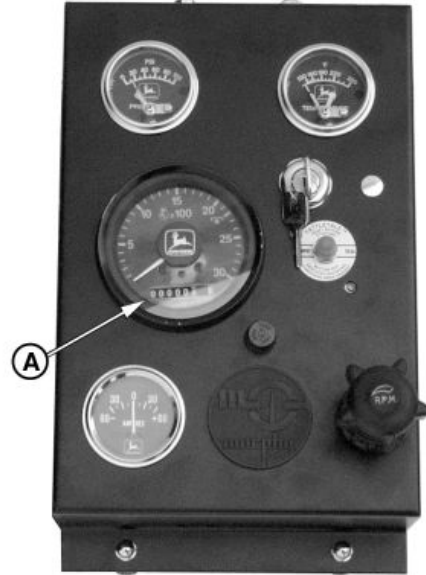

Check Engine Speed On Tachometer

OURGP11,000000B -19-24JUN04-1/1

RG11299A—UN—17AUG00

Checking Engine Electrical Ground Connections

Keep all engine ground connections clean and tight to prevent electrical arcing which can damage electronic components.

OUOD002,0000169 -19-08OCT01-1/1

Checking Cooling System

CAUTION: Explosive release of fluids from pressurized cooling system can cause serious burns.

Shut off engine. Only remove filler cap when cool enough to touch with bare hands. Slowly loosen cap to first stop to relieve pressure before removing completely.

IMPORTANT: Air must be expelled from cooling system when system is refilled. Loosen temperature sending unit fitting at rear of cylinder head or plug in thermostat housing to allow air to escape when filling system. Retighten fitting or plug when all the air has been expelled.

1. Visually check entire cooling system for leaks. Tighten all clamps securely.

2. Thoroughly inspect all cooling system hoses for hard, flimsy, or cracked condition. Replace hoses if any of the above conditions are found.



High-Pressure Fluids

RG, RG34710, 5580 -19-20MAY96-1/1

TS281—UN—15APR13

Replenishing Supplemental Coolant Additives (SCAs) Between Coolant Changes

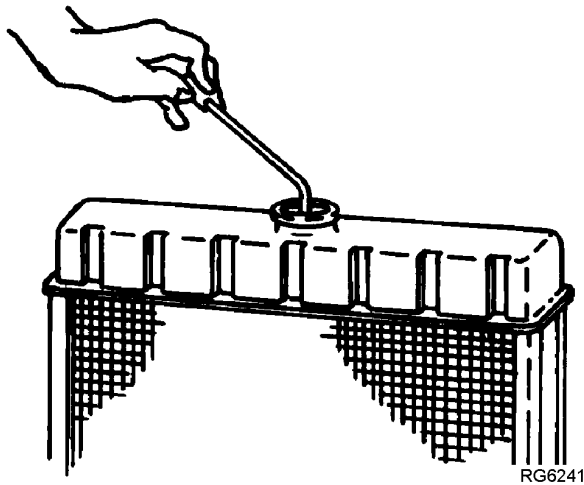

Radiator Coolant Check

RG6241

RG6261—UN—08DEC97

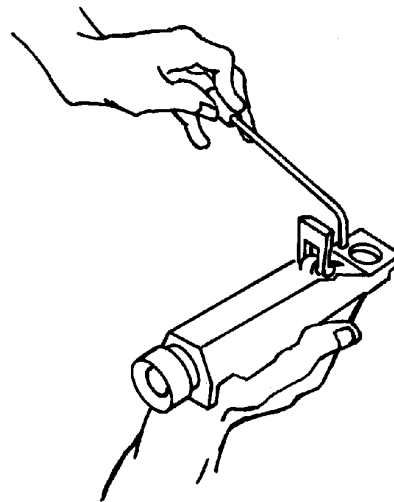

JT07298 Coolant/Battery Tester

RG6262

RG6262—UN—05DEC97

IMPORTANT: Do not add supplemental coolant additives when the cooling system is drained and refilled with John Deere COOL-GARD®

NOTE: If system is to be filled with coolant that does not contain SCAs, the coolant must be precharged. Determine the total system capacity and premix with 3% John Deere Coolant Conditioner.

Through time and use, the concentration of coolant additives is gradually depleted during engine operation. Periodic replenishment of inhibitors is required, even when John Deere COOL-GARD® is used. The cooling system must be recharged with additional supplemental coolant additives available in the form of liquid coolant conditioner.

Maintaining the correct coolant conditioner concentration (SCAs) and freeze point is essential in your cooling system to protect against rust, liner pitting and corrosion, and freeze-ups due to incorrect coolant dilution.

John Deere LIQUID COOLANT CONDITIONER is recommended as a supplemental coolant additive in John Deere engines.

DO NOT mix one brand of SCA with a different brand.

Test the coolant solution every 500 hours or 12 months of operation using either John Deere coolant test strips or a COOLSCAN® analysis. If a COOLSCAN® analysis is not

*COOL-GARD is a registered trademark of Deere & Company
COOLSCAN is a registered trademark of Deere & Company*

available, recharge the system per instructions printed on label of John Deere Liquid Coolant Conditioner.

IMPORTANT: ALWAYS maintain coolant at correct level and concentration. DO NOT operate engine without coolant even for a few minutes.

If frequent coolant makeup is required, the glycol concentration should be checked with JT07298 Coolant/Battery Tester to ensure that the desired freeze point is maintained. Follow manufacturer's instructions provided with Coolant/Battery Tester.

Add the manufacturer's recommended concentration of supplemental coolant additive. DO NOT add more than the recommended amount.

The use of non-recommended supplemental coolant additives may result in additive drop-out and gelation of the coolant.

If other coolants are used, consult the coolant supplier and follow the manufacturer's recommendation for use of supplemental coolant additives.

See [DIESEL ENGINE COOLANTS AND SUPPLEMENTAL ADDITIVE INFORMATION](#) for proper mixing of coolant ingredients before adding to the cooling system.

DPSG,OUOD002,1921 -19-07JAN02-1/1

Testing Diesel Engine Coolant

Maintaining adequate concentrations of glycol and inhibiting additives in the coolant is critical to protect the engine and cooling system against freezing, corrosion, and cylinder liner erosion and pitting.

Test the coolant solution at intervals of 12 months or less and whenever excessive coolant is lost through leaks or overheating.

Coolant Test Strips

Coolant test strips are available from your John Deere dealer. These test strips provide a simple, effective method to check the freeze point and additive levels of your engine coolant.

When Using John Deere COOL-GARD II

John Deere COOL-GARD II Premix™, COOL-GARD II PG Premix and COOL-GARD II Concentrate are maintenance free coolants for up to six years or 6000 hours of operation, provided that the cooling system is topped off using only John Deere COOL-GARD II Premix or COOL-GARD II PG premix. Test the coolant condition annually with coolant test strips designed for use with John Deere COOL-GARD II coolants. If the test strip chart indicates that additive is required, add John Deere COOL-GARD II Coolant Extender as directed.

COOL-GARD is a trademark of Deere & Company

Add only the recommended concentration of John Deere COOL-GARD II Coolant Extender. DO NOT add more than the recommended amount.

When Using Nitrite-Containing Coolants

Compare the test strip results to the supplemental coolant additive (SCA) chart to determine the amount of inhibiting additives in your coolant and whether more John Deere Liquid Coolant Conditioner should be added.

Add only the recommended concentration of John Deere Liquid Coolant Conditioner. DO NOT add more than the recommended amount.

Coolant Analysis

For a more thorough evaluation of your coolant, perform a coolant analysis. The coolant analysis can provide critical data such as freezing point, antifreeze level, pH, alkalinity, nitrite content (cavitation control additive), molybdate content (rust inhibitor additive), silicate content, corrosion metals, and visual assessment.

Contact your John Deere dealer for more information on coolant analysis.

DX,COOL9 -19-11APR11-1/1

Pressure Testing Cooling System

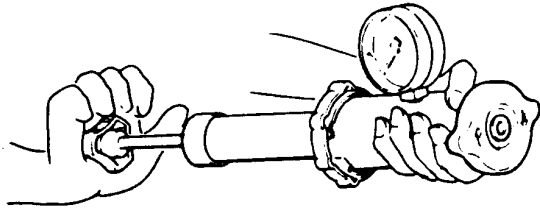

Test Radiator Cap

RG6657—UN—20JAN93

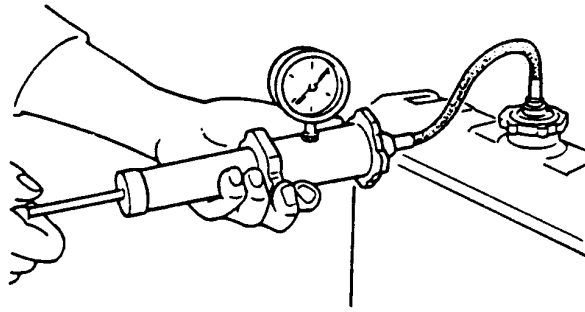

Test Cooling System

RG6658—UN—20JAN93

CAUTION: Explosive release of fluids from pressurized cooling system can cause serious burns.

Shut off engine. Only remove filler cap when cool enough to touch with bare hands. Slowly loosen cap to first stop to relieve pressure before removing completely.

Test Radiator Cap

1. Remove radiator cap and attach to D05104ST Tester as shown.
2. Pressurize cap to specification listed. Gauge should hold pressure for 10 seconds within the normal range if cap is acceptable.

If gauge does not hold pressure, replace radiator cap.

Specification

Radiator Cap Holding Pressure (Not Opening For 10 Seconds)—Pressure..... 70 kPa (0.7 bar) (10 psi) minimum

3. Remove the cap from gauge, turn it 180°, and retest cap. This will verify that the first measurement was accurate.

Test Cooling System

NOTE: Engine should be warmed up to test overall cooling system.

1. Allow engine to cool, then carefully remove radiator cap.
2. Fill radiator with coolant to the normal operating level.

IMPORTANT: DO NOT apply excessive pressure to cooling system, doing so may damage radiator and hoses.

3. Connect gauge and adapter to radiator filler neck. Pressurize cooling system to specification listed for radiator cap.
4. With pressure applied, check all cooling system hose connections, radiator, and overall engine for leaks.

If leakage is detected, correct as necessary and pressure test system again.

If no leakage is detected, but the gauge indicated a drop in pressure, coolant may be leaking internally within the system or at the block-to-head gasket. Have your engine distributor or servicing dealer correct this problem immediately.

RG, RG34710, 5586 -19-07JAN02-1/1

Adjusting Variable Speed (Droop) on Generator Set Engines

Stanadyne Mechanical Injection Pumps Only

1. Warm engine to normal operating temperature.
2. When necessary, disconnect throttle linkage or cable.
3. Adjust slow idle (C) and adjust fast idle (B) speed when necessary.
4. Run engine at fast idle, then apply load until reaching rated speed.
5. Check power. Adjust with the screw (A) if needed.
6. Remove load from engine.
7. Again check and adjust fast idle if screw (A) has been turned.
8. Repeat procedure until both the engine power and the fast idle speed are correct.
9. Reinstall throttle linkage if previously removed.

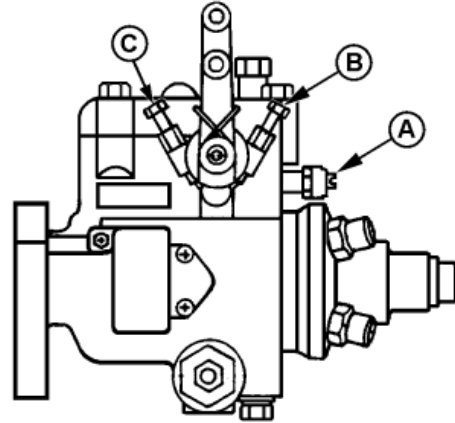

Droop Adjustment Screw

A—Adjustment Screw
B—Fast Idle Adjustment

C—Slow Idle Adjustment

Continued on next page

RG, RG34710, 5583 -19-28JAN02-1/2

RG12066—UN—28JAN02

DENSO In-Line Injection Pumps Only

1. Check for specified no-load (frequency). If governor regulation is within 5–7% range, no adjustment is necessary.
2. If governor regulation is above 7% or below 5%, stop engine and remove cap nuts from adjusting screws before making adjustments.
3. Remove droop adjusting screw access plug (B, shown removed) from top of governor housing.
4. Back out slow idle (adjusting) screw (D) and bumper screw. Pull back on throttle lever (F, toward rear of governor housing) by hand until the droop adjusting screw (C) inside housing can be adjusted through the access plug hole.
5. Screw the droop screw in (clockwise), counting the turns until screw bottoms out. Then, return screw to original setting.

NOTE: A noticeable click will occur at each 1/4 turn of droop adjusting screw. One click clockwise will increase no-load speed approximately 10 rpm, counterclockwise will reduce speed by 10 rpm.

6. Screw in the droop screw (clockwise) no more than 1/2 turn (two clicks) at a time to reduce governor droop. Turn counterclockwise no more than two clicks at a time to increase governor droop (to reduce governor sensitivity).
7. Replace access plug in top of governor housing. Start engine, apply full (100%) load, and readjust high idle adjusting screw until 1500 rpm is obtained at the specified power.
8. Screw in idle (bumper) spring until engine speed increases 5–10 rpm.
9. Repeat steps 4 through 7 until governor regulation is within the 5–7% range.
10. Replace all cap nuts onto adjusting screws and tighten lock nuts securely.

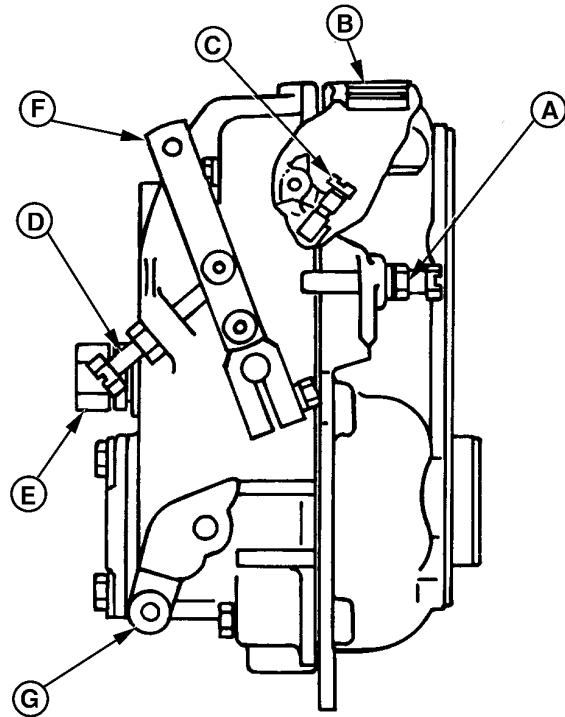

DENSO In-Line Injection Pump

- | | |
|----------------------------------------------|----------------------------|
| A—Fast Idle (Stop) Screw | E—Idle (Bumper) Spring |
| B—Droop Adjusting Screw Access Plug Location | F—Throttle Lever |
| C—Droop Adjusting Screw | G—Mechanical Shutoff Lever |
| D—Slow Idle (Adjusting) Screw | |

Delphi (Lucas) Injection Pumps Only

See your authorized Delphi (Lucas) Repair Station for speed droop adjustment. This service requires that an internal pump adjustment be made.

RG5752—UN—03NOV97

RG, RG34710, 5583 -19-28JAN02-2/2

Checking Crankshaft Vibration Damper (6-Cylinder Engine Only)

IMPORTANT: Crankshaft vibration damper assembly is not repairable and should be replaced every 4500 hours or 60 months, whichever occurs first.

1. Remove belts (shown removed).
2. Grasp crankshaft vibration damper with both hands and attempt to turn it in both directions. If rotation is felt, crankshaft vibration damper is defective and should be replaced.
3. Check crankshaft vibration damper radial runout by positioning dial indicator so probe contacts crankshaft vibration damper outer diameter.
4. With engine at operating temperature, rotate crankshaft using JDE83 or JD81-1 flywheel turning tool.
5. Note dial indicator reading. If runout exceeds specification, replace crankshaft vibration damper.

Specification

Crankshaft Vibration Damper—Maximum	
Radial Runout.....	1.50 mm (0.060 in)

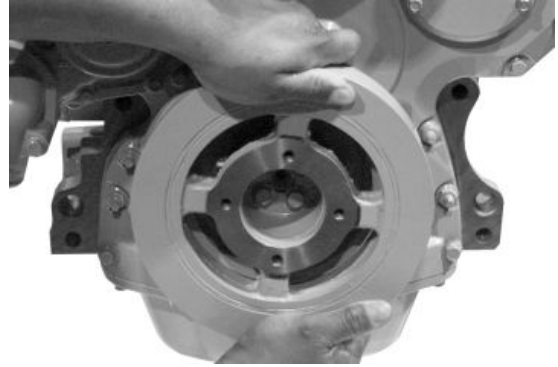

Grasp Vibration Damper

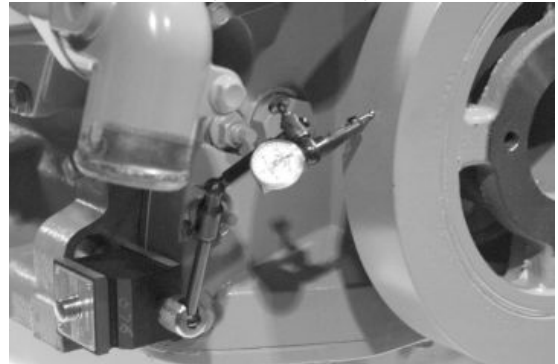

Check Runout

RG8018 —UN—15JAN99

RG7508 —UN—23NOV97

RG, RG34710, 5585 -19-27OCT15-1/1

Flushing and Refilling Cooling System

⚠ CAUTION: Explosive release of fluids from pressurized cooling system can cause serious burns.

Shut off engine. Only remove filler cap when cool enough to touch with bare hands. Slowly loosen cap to first stop to relieve pressure before removing completely.

NOTE: When John Deere COOL-GARD is used, the drain interval is 3000 hours or 36 months. The drain interval may be extended to 5000 hours or 60 months of operation, **provided that the coolant is tested annually AND additives are replenished, as needed, by adding a supplemental coolant additive (SCA).**

If COOL-GARD is not used, the flushing interval is 2000 hours or 24 months of operation.

Drain old coolant, flush the entire cooling system, test thermostats, and fill with recommended clean coolant per the following procedure.

1. Pressure test entire cooling system and pressure cap if not previously done. (See PRESSURE TESTING COOLING SYSTEM, in the Lubrication and Maintenance/500 Hour/12 Month Section.)
2. Slowly open the engine cooling system filler cap or radiator cap (A) to relieve pressure and allow coolant to drain faster.



High-Pressure Fluids

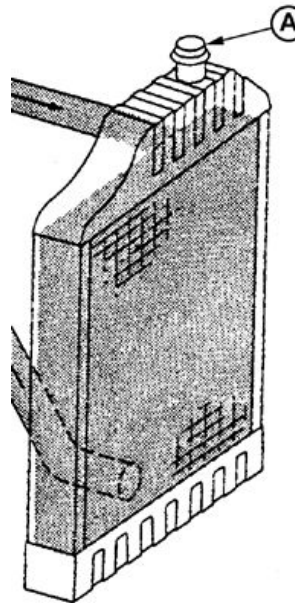

Radiator Cap

Continued on next page

OURGP11,000000C -19-24JUN04-1/2

TS281—UN—15APR13

RG12833—UN—13FEB03

- Open engine block drain valve (A) on left side of engine. Drain all coolant from engine block.

NOTE: These engines use several different oil filter adapters. Use either drain plug (B) or (C) to drain coolant, whichever is more accessible for the oil filter adapter on your engine.

- Open radiator drain valve. Drain all coolant from radiator.
- Remove thermostats at this time, if not previously done. Install cover (without thermostats) using old gasket and tighten cap screws to 47 N·m (35 lb-ft).
- Test thermostat opening temperature. (See Inspecting Thermostats And Testing Opening Temperature in Service As Required Section.)
- Close all drain valves after coolant has drained.

CAUTION: Do not run engine longer than 10 minutes. Doing so may cause engine to overheat which may cause burns when radiator water is draining.

- Fill the cooling system with clean water. Run the engine about 10 minutes to stir up possible rust or sediment.
- Stop engine, pull off lower radiator hose and remove radiator cap. Immediately drain the water from system before rust and sediment settle.
- After draining water, close drain valves. Reinstall radiator cap and radiator hose and clamp. Fill the cooling system with clean water and a heavy duty cooling system cleaner such as Fleetguard® RESTORE™ and RESTORE PLUS™. Follow manufacturer's directions on label.
- After cleaning the cooling system, drain cleaner and fill with water to flush the system. Run the engine about 10 minutes, remove radiator cap and pull off lower radiator hose to drain out flushing water.
- Close all drain valves on engine and radiator. Reinstall radiator hose and tighten clamps securely. Install thermostats using a new gasket. (See TESTING THERMOSTATS OPENING TEMPERATURE later in this section.)

IMPORTANT: Air must be expelled from cooling system when system is refilled. Loosen

*Fleetguard is a trademark of Cummins Engine Company, Inc.
RESTORE is a trademark of Fleetguard.
RESTORE PLUS is a trademark of Fleetguard.*

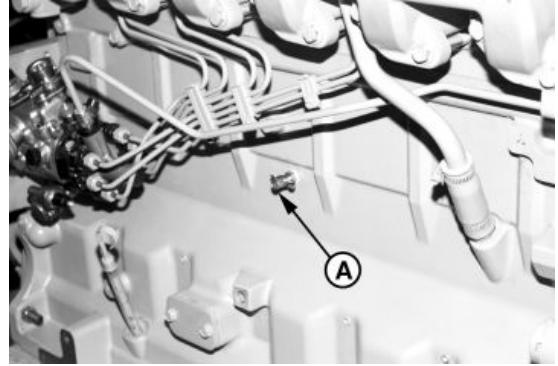

Engine Block Drain Valve

A—Engine Block Drain Valve C—Engine Block Drain Plug
B—Engine Block Drain Plug

temperature sending unit fitting at rear of cylinder head or plug in thermostat housing to allow air to escape when filling system. Retighten fitting or plug after filling cooling system.

NOTE: Coolant capacity may vary depending on application.

- Add coolant to radiator until coolant touches bottom of filler neck. (See specification for capacity.) Install radiator cap.

Specification

4.5 L Engine— Coolant Capacity.....	8.5 L (9 qt)
6.8 L Engine—Coolant Capacity.....	11.3 L (12 qt)

- Run engine until it reaches operating temperature. This mixes the solution uniformly and circulates it through the entire system. The normal engine coolant temperature range is 82°—94°C (180° — 202°F).
- After running engine, check coolant level and entire cooling system for leaks.
- Inspect the fan belt for wear and check belt tension. (See Checking Belt Tensioner Spring Tension and Belt Wear in Lubrication and Maintenance 500 Hour/12 Month section.)

OURGP11,000000C -19-24JUN04-2/2

RG8019A —UN—19JUN00

Testing Thermostats Opening Temperature

To Remove Thermostat(s)

NOTE: On some engines, the coolant manifold/thermostat housing is an integral part of the cylinder head.

⚠ CAUTION: Explosive release of fluids from pressurized cooling system can cause serious burns. **DO NOT** drain coolant until it has cooled below operating temperature. Always loosen radiator pressure cap or drain valve slowly to relieve pressure.

1. Visually inspect area around thermostat housing for leaks.
2. Remove radiator pressure cap and partially drain cooling system.
3. Remove thermostat cover-to-water pump tube (A) and seal.

A—Cover-To-Coolant Pump
Tube



High Pressure Fluids

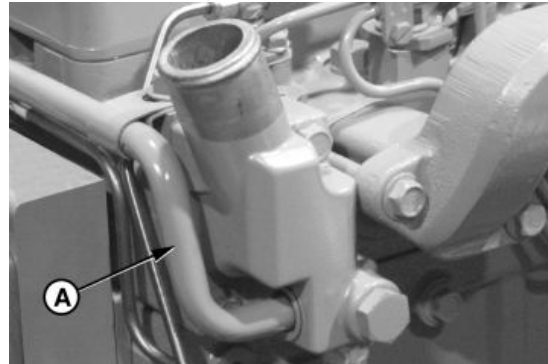

Thermostat Cover-to-Water Pump Tube

DPSG, RG34710, 112 -19-07JAN02-1/5

4. Remove thermostat cover (B) with gasket.
5. Remove thermostat(s)
6. Remove and discard all gasket material. Clean gasket surfaces.
7. Clean and check cover for cracks or damage.

B—Thermostat Cover

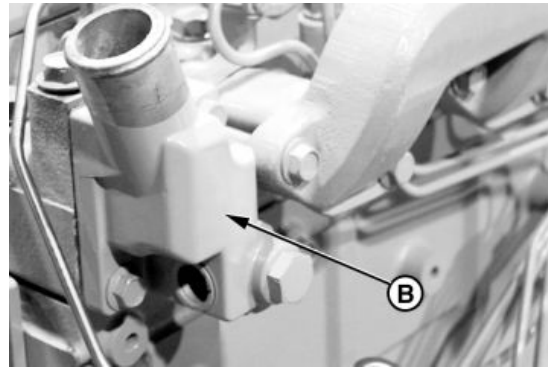

Thermostat Cover

Continued on next page

DPSG, RG34710, 112 -19-07JAN02-2/5

T5281—UN—15APR13

RG8115A—UN—15JAN88

RG7921A—UN—13NOV97

Testing Thermostats Opening Temperature

1. Remove thermostat(s).
2. Visually inspect thermostat(s) for corrosion or damage. If dual thermostats, replace as a matched set as necessary.

⚠ CAUTION: DO NOT allow thermostat or thermometer to rest against the side or bottom of container when heating water. Either may rupture if overheated.

3. Suspend thermostat and a thermometer in a container of water.
4. Stir the water as it heats. Observe opening action of thermostat and compare temperatures with the specification given in chart below.

NOTE: Due to varying tolerances of different suppliers, initial opening and full open temperatures may vary slightly from specified temperatures.

THERMOSTAT TEST SPECIFICATIONS

Rating	Initial Opening (Range)	Full Open (Nominal)
71°C (160°F)	69—72°C (156—162°F)	84°C (182°F)
77°C (170°F)	74—78°C (166—172°F)	89°C (192°F)
82°C (180°F)	80—84°C (175—182°F)	94°C (202°F)
89°C (192°F)	86—90°C (187—194°F)	101°C (214°F)
90°C (195°F)	89—93°C (192—199°F)	103°C (218°F)
92°C (197°F)	89—93°C (193—200°F)	105°C (221°F)
96°C (205°F)	94—97°C (201—207°F)	100°C (213°F)
99°C (210°F)	96—100°C (205—212°F)	111°C (232°F)

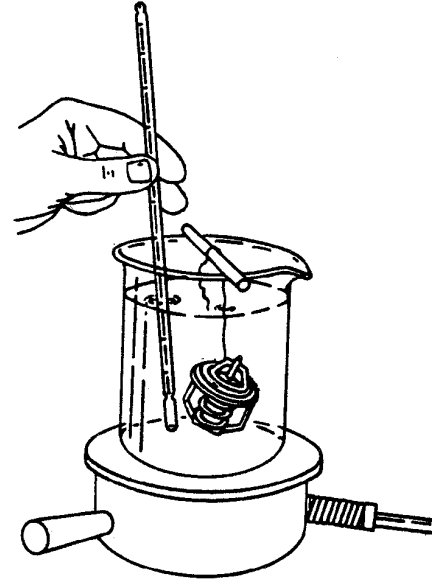

Testing Thermostat Opening Temperature

5. Remove thermostat and observe its closing action as it cools. In ambient air the thermostat should close completely. Closing action should be smooth and slow.
6. Replace any defective thermostat. On a dual thermostat engine, replace both thermostats.

Continued on next page

DPSG, RG34710, 112 - 19-07JAN02-3/5

RG5971 —UN—23NOV97

To Install Thermostats

IMPORTANT: Install manifold gasket so that smaller (round) holes are at lower left and upper right corners of manifold (matching studs A).

1. Clean all gasket material from thermostat cover and housing mounting surfaces.
2. Using guide studs (A) to keep gasket in place, install a new gasket on cylinder head.
3. Install thermostat(s) with jiggle wire facing up in the 12 o'clock position.
4. Using a screwdriver to hold thermostat(s) in place, install thermostat(s) and water manifold/thermostat cover.
5. Tighten cover cap screws to 70 N·m (52 lb-ft).
6. Lubricate new O-ring with PT507 Multi-Purpose Grease. Install seal (B) in thermostat cover.

A—Guide Studs

B—Seal

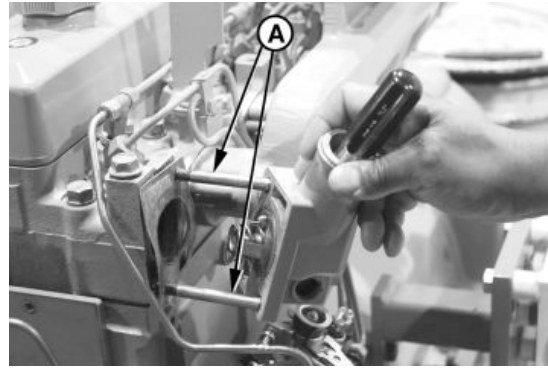

Installing Thermostat Cover



Thermostat Cover Seal

RG7614A—UN—06NOV97

RG7921B—UN—13NOV97

DPSG, RG34710, 112 -19-07JAN02-4/5

7. Install coolant manifold/thermostat cover-to-coolant pump tube (C). Tighten clamps.
8. If not already done, fill cooling system and check for leaks.

IMPORTANT: Air must be expelled from cooling system when filling. Loosen temperature sending unit fitting at rear of cylinder head or plug in thermostat housing to allow air to escape when filling system. Tighten fitting or plug when all air has been expelled.

C—Cover-To-Coolant Pump Tube



Cover-To-Coolant Pump Tube

RG8115B—UN—15JAN98

DPSG, RG34710, 112 -19-07JAN02-5/5

Check and Adjust Valve Clearance

CAUTION: To prevent accidental starting of engine while performing valve adjustments, always disconnect **NEGATIVE (—)** battery terminal.

IMPORTANT: Valve clearance **MUST BE** checked and adjusted with engine **COLD**.

1. Remove rocker arm cover and crankcase ventilator tube.

IMPORTANT: Visually inspect contact surfaces of valve tips and rocker arm wear pads. Check all parts for excessive wear, breakage, or cracks. Replace parts that show visible damage.

Rocker arms that exhibit excessive valve clearance should be inspected more thoroughly to identify damaged parts.

2. Remove plastic plugs or cover plate from engine timing/rotation hole (A) and timing pin hole (B).

NOTE: Some engines are equipped with flywheel housings which do not allow use of an engine flywheel rotation tool. These engines may be rotated from front nose of engine, using JDG966 Crankshaft Front/Rear Rotation Adapter.

3. Using JDE83 or JD81-1 Flywheel Turning Tool, rotate engine flywheel in running direction (clockwise viewed from front) until No. 1 cylinder is at TDC compression stroke. Insert JDG1571 or JDE81-4 Timing Pin in flywheel.

If No.1 cylinder rocker arms are loose, the engine is at No. 1 TDC compression.

If No. 1 cylinder rocker arms are not loose, rotate engine one full revolution (360°) to No. 1 TDC compression.

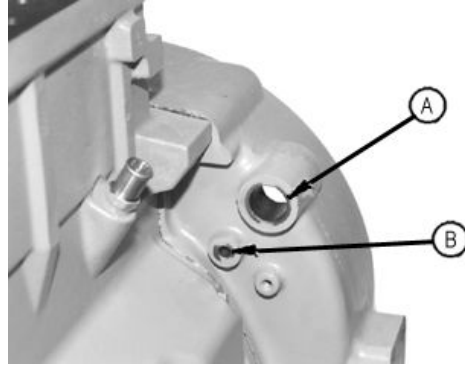

Flywheel Housing Timing Holes

A—Timing/Rotation Hole

B—Timing Pin Hole

4. With engine lock-pinned at TDC of No. 1 piston's compression stroke, check valve clearance to following specifications. (Use sequence for 4-cylinder or 6-cylinder engines as outlined on next page.)

Specification

Intake Valve Clearance	
For Checking (Rocker Arm-to-Valve Tip) (Engine Cold)—Clearance.....	0.31—0.38 mm (0.012—0.015 in.)
Exhaust Valve Clearance	
For Checking (Rocker Arm-to-Valve Tip) (Engine Cold)—Clearance.....	0.41—0.48 mm (0.016—0.019 in.)

Continued on next page

DPSG,RG41165,137 -19-16JAN02-1/4

RG7408—UN—06AUG96

- If valves need adjusting, use the appropriate valve clearance adjustment procedure on the next page and adjust to specifications below. Loosen the jam nut (A) on rocker arm adjusting screw. Turn adjusting screw until feeler gauge slips with a slight drag. Hold the adjusting screw from turning with screwdriver and tighten jam nut to specifications. Recheck clearance again after tightening jam nut. Readjust clearance as necessary.

Specification

Intake Valve Clearance	
For Adjusting (Rocker Arm-to-Valve Tip) (Engine Cold)—Clearance.....	0.36 mm (0.014 in.)
Exhaust Valve Clearance	
For Adjusting (Rocker Arm-to-Valve Tip) (Engine Cold)—Clearance.....	0.46 mm (0.018 in.)
Rocker Arm Adjusting Screw Jam Nut—Torque.....	27 N·m (20 lb-ft)

- Replace rocker arm cover and crankcase ventilator tube.

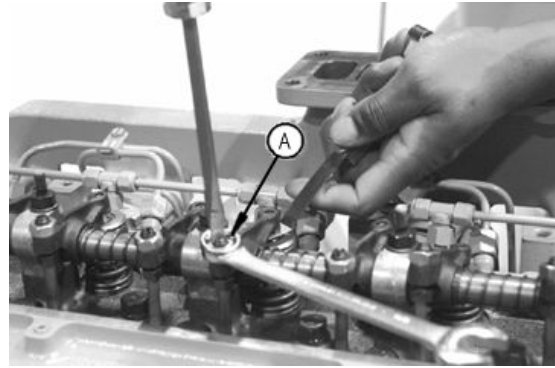

Adjusting Valves

A—Adjusting Screw Jam Nut

RG7409 — UN — 06AUG96

DPSG, RG41165, 137 -19-16JAN02-2/4

4-Cylinder Engine:

NOTE: Firing order is 1-3-4-2.

- Using JDE81-4 Timing Pin, lock No. 1 piston at TDC compression stroke (B).
- Adjust valve clearance on No. 1 and 3 exhaust valves and No. 1 and 2 intake valves.
- Turn crankshaft 360°. Lock No. 4 piston at TDC compression stroke (C).
- Adjust valve clearance on No. 2 and 4 exhaust valves and No. 3 and 4 intake valves.

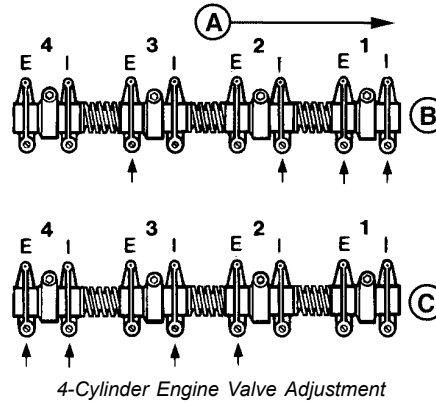

A—Front of Engine
 B—No. 1 Piston TDC Compression
 C—No. 4 Piston TDC Compression
 E—Exhaust Valve
 I—Intake Valve

Continued on next page

DPSG, RG41165, 137 -19-16JAN02-3/4

RG4776 — UN — 31OCT97

6-Cylinder Engine:

NOTE: Firing order is 1-5-3-6-2-4.

1. Lock No. 1 piston at TDC compression stroke (B).
2. Adjust valve clearance on No. 1, 3 and 5 exhaust valves and No. 1, 2, and 4 intake valves.
3. Turn crankshaft 360°. Lock No. 6 piston at TDC compression stroke (C).
4. Adjust valve clearance on No. 2, 4 and 6 exhaust valves and No. 3, 5, and 6 intake valves.

- | | |
|--------------------------------|-----------------|
| A—Front of Engine | E—Exhaust Valve |
| B—No. 1 Piston TDC Compression | I—Intake Valve |
| C—No. 6 Piston TDC Compression | |

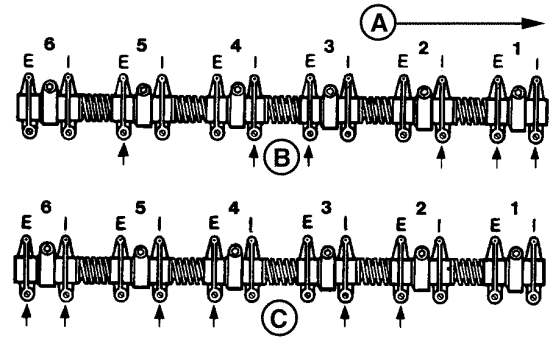

6-Cylinder Engine Valve Adjustment

RG4777 —UN—310C197

DPSG, RG41165, 137 -19-16JAN02-4/4

Service as Required

Additional Service Information

This is not a detailed service manual. If you want more detailed service information, use the form in the back of this manual to order a component technical manual.

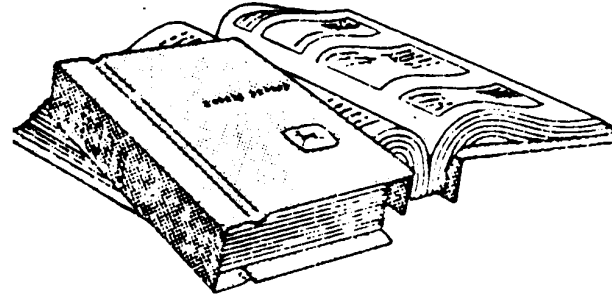

Component Technical Manual

RG, RG34710, 5591 -19-20MAY96-1/1

RG4624 —JUN—15DEC88

Do Not Modify Fuel System

IMPORTANT: Modification or alteration of the injection pump (arrow), the injection pump timing, or the fuel injectors in ways not recommended by the manufacturer will terminate the warranty obligation to the purchaser.

In addition, tampering with fuel system which alters emission-related equipment on engines may result in fines or other penalties, per EPA regulations or other local emission laws.

Do not attempt to service injection pump or fuel injectors yourself. Special training and special tools are required. (See your authorized servicing dealer or engine distributor.)

Never steam clean or pour cold water on an injection pump while it is still warm. To do so may cause seizure of pump parts.

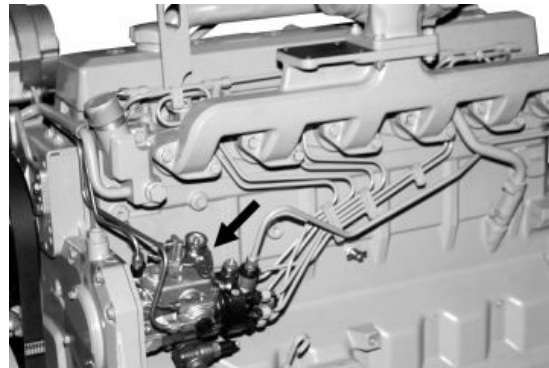

Fuel Injection Pump

OURGP12,000004D -19-03AUG04-1/1

RG8022A —JUN—19JUN00

Adding Coolant

⚠ CAUTION: Explosive release of fluids from pressurized cooling system can cause serious burns.

Shut off engine. Only remove filler cap when cool enough to touch with bare hands. Slowly loosen cap to first stop to relieve pressure before removing completely.

IMPORTANT: Never pour cold liquid into a hot engine, as it may crack cylinder head or block. **DO NOT** operate engine without coolant for even a few minutes.

John Deere TY15161 Cooling System Sealer may be added to the radiator to stop leaks. **DO NOT** use any other stop-leak additives in the system.

Air must be expelled from cooling system when coolant is added.

1. Loosen temperature sending unit fitting at rear of cylinder head or plug in side of thermostat housing to allow air to escape when filling system.

IMPORTANT: When adding coolant to the system, use the appropriate coolant solution. (See **ENGINE COOLANT SPECIFICATIONS** in Fuels, Lubricants, and Coolant Section for mixing of coolant ingredients before adding to cooling system.)

Do not overfill cooling system. A pressurized system needs space for heat expansion without overflowing at top of radiator.

2. Remove radiator cap (A) and fill until coolant level touches bottom of radiator filler neck.
3. Tighten plugs and fittings when air has been expelled from system.
4. Run engine until it reaches operating temperature.



High-Pressure Fluids

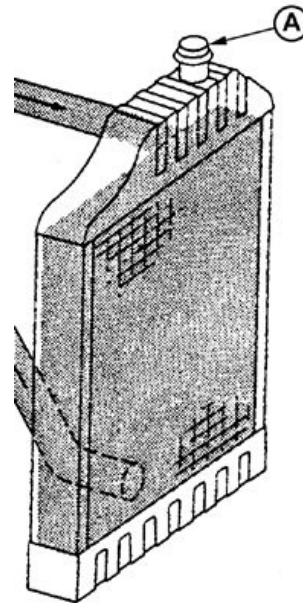

Radiator Filler Cap

A—Radiator Filler Cap

OURGP12,000049 -19-22JUL04-1/1

T5281—UN—15APR13

RG12833—UN—13FEB03

Pre-Start Cleaning Guide

IMPORTANT: Before cleaning machine, allow ample time for hot surfaces to cool.

IMPORTANT: Do not direct high-pressure spray from hose output directly at or close to electrical connections and sensors.

Rigorous cleaning as needed is recommended. Clean more frequently during heavy machine use, and when weather conditions are dry.

- Check enclosed areas daily. Clean the engine and other enclosed areas of equipment to remove debris and any buildup of oil and grease. Keep the engine and engine compartment free of combustible material.
- Check for debris buildup daily on and around intake systems, exhaust systems, and intercooler piping systems. Verify that there are no holes or leaks in intake or exhaust systems. Do not allow debris to build up near hot exhaust components. Verify that hot exhaust components are cleaned as often as environmental conditions require.
- Inspect cooling system daily to determine whether cooling system needs cleaning. Visible buildup of residue that blocks airflow may degrade machine performance and requires more frequent cleaning depending on environmental conditions.

- Inspect difficult to observe areas daily as conditions may require additional cleaning care to remove debris.
- Check for oil and fuel leaks daily. Replace or repair any sources of leaks, including gaskets, seals, breather tubes, fittings, and fluid lines.

Maintenance and Service Reminders

- Keep surfaces free of grease and oil.
- Clean up after hydraulic and other fluid leaks.
- Fuel Lines — Check for leaks, cracks, and kinks that require service before use.
- Fuel Pumps — Check fittings, especially compression ring couplings, for cracks and leaks.
- Fuel Injectors — Check pressure and return lines for signs of leaks.
- When servicing fuel filter or draining water separator, avoid fuel spills. Immediately clean up any fuel spill.
- Handle transmission and power steering fluids with care. Immediately clean up any spills, especially around fill points.
- Check for transmission case venting system seepage, transmission case leakage, power steering cylinder leakage, or power steering line leakage.
- Check for loose electrical connectors, damaged wiring, corrosion, and poor connections.

ZE59858,0000009 -19-20MAY13-1/1

Replacing Single Stage Air Cleaner

IMPORTANT: ALWAYS REPLACE air cleaner when air restriction indicator shows a vacuum of 625 mm (25 in.) H₂O, is torn, or visibly dirty.

NOTE: This procedure applies to John Deere single stage air cleaner kits. Refer to manufacturers' instructions for servicing air cleaners not supplied by John Deere.

1. If equipped, loosen body clamp.
2. Loosen clamp around outlet neck (A).
3. Remove air cleaner.
4. Install new filter so that overlap (B) of air cleaner outlet neck and engine intake pipe is to specification below.

Specification

Air Cleaner Neck to	
Engine Intake—Overlap.....	38 mm (1.5 in)

5. Tighten neck clamp (A) to specification below.

Specification

Air Cleaner Neck	
Clamp—Torque.....	6.8 N·m (60 lb-in.)

IMPORTANT: Do NOT overtighten body clamp. Overtightening may cause crushing of air cleaner body. Tighten body clamp only until snug.

6. If equipped, tighten body clamp until snug.

IMPORTANT: Whenever the air cleaner has been serviced or removed, ALWAYS fully depress the air restriction indicator reset button (if equipped) to assure accurate readings.

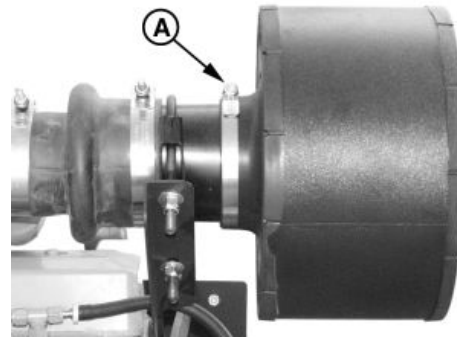

Single Stage Air Filter

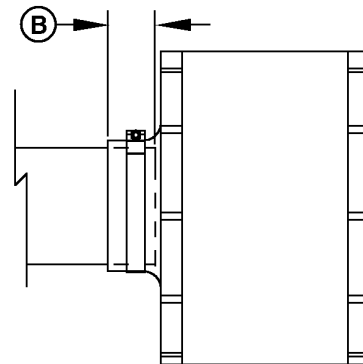

Installation of Single Stage Air Cleaner

A—Outlet Neck Clamp

B—Filter to Engine Overlap

7. If equipped, fully depress air restriction indicator reset button and release to reset indicator.

RG, RG34710, 5594 -19-07JAN02-1/1

RG11319A—UN—06SEP00

RG11320—UN—07SEP00

Replacing Axial Seal Air Cleaner Filter Element

IMPORTANT: ALWAYS REPLACE primary air cleaner element when air restriction indicator shows a vacuum of 625 mm (25 in.) H₂O, is torn, or visibly dirty.

NOTE: This procedure applies to John Deere 2-stage axial seal air cleaner kits. Refer to manufacturers' instructions for servicing air cleaners not supplied by John Deere.

1. Remove wing nut and remove canister cover shown in small illustration inset.
2. Remove wing nut (A) and remove primary element (B) from canister.
3. Thoroughly clean all dirt from inside canister.

NOTE: Some engines may have a dust unloader valve (C) on the air cleaner. If equipped, squeeze valve tip to release any trapped dirt particles.

IMPORTANT: Remove secondary (safety) element (E) ONLY for replacement. DO NOT attempt to clean, wash, or reuse secondary element. Replacement of secondary element is usually necessary ONLY when primary element has a hole in it.

4. To replace secondary element, remove retaining nut (D) and secondary element (E). Immediately replace secondary element with new element to prevent dust from entering air intake system.
5. Install new primary element and tighten wing nut securely. Install cover assembly and tighten retaining wing nut securely.

IMPORTANT: Whenever the air cleaner has been serviced or had cover removed, ALWAYS fully depress the air restriction indicator reset button (if equipped) to assure accurate readings.

6. If equipped, fully depress air restriction indicator reset button and release to reset indicator.

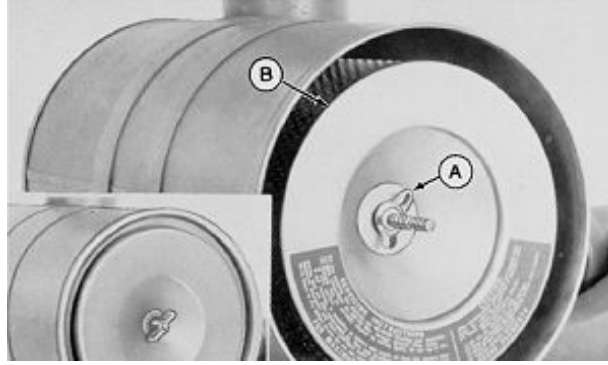

Wing Nut and Primary Element

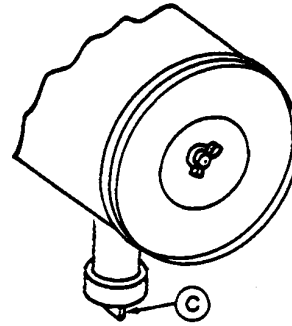

Dust Unloader Valve

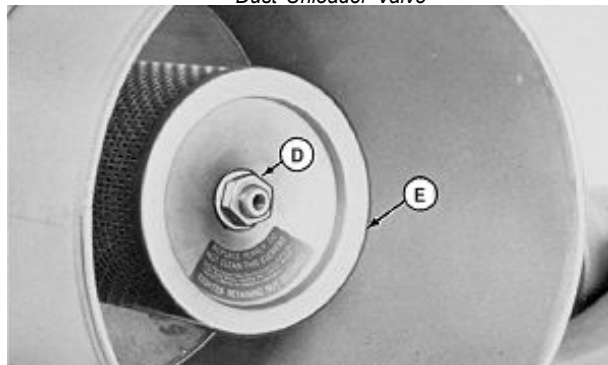

Retaining Nut and Secondary Element

A—Wing Nut
B—Primary Element
C—Dust Unloader Valve

D—Retaining Nut
E—Secondary Element

RG4686 —UN—20DEC88

RG4687 —UN—20DEC88

RG11068 —UN—26JUN00

RG41165,000008A -19-12NOV01-1/1

Replacing Radial Seal Air Cleaner Filter Element

IMPORTANT: ALWAYS REPLACE primary air cleaner element when air restriction indicator shows a vacuum of 625 mm (25 in.) H₂O, is torn, or visibly dirty.

NOTE: This procedure applies to John Deere 2-stage radial seal air cleaner kits. Refer to manufacturers' instructions for servicing air cleaners not supplied by John Deere.

1. Unlatch and remove dust cap/cover (A) of air cleaner.
2. Move end of filter (B) back and forth gently to break seal.
3. Pull filter (B) off outlet tube and out of housing.
4. Thoroughly clean all dirt from inside housing and from outlet bore.

IMPORTANT: Remove secondary (safety) element (C) ONLY for replacement. DO NOT attempt to clean, wash, or reuse secondary element. Replacement of secondary element is usually necessary ONLY when primary element has a hole in it.

5. To replace secondary element (C), pull filter element out gently. Immediately replace secondary element with new element to prevent dust from entering air intake system.
6. Install new primary filter element. Apply pressure by hand at outer rim of filter.

IMPORTANT: Do NOT use latches on cover to force filter into air cleaner. Using cover to force filter will damage cleaner housing.

7. Close housing with dust unloader valve aimed down and latch latches.

IMPORTANT: Whenever the air cleaner has been serviced or cover has been removed, ALWAYS fully depress the air restriction indicator reset button (if equipped) to assure accurate readings.

8. If equipped, fully depress air restriction indicator reset button and release to reset indicator.



Dust Cap/Cover



Primary Filter Element

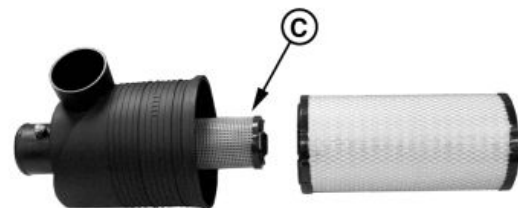

Secondary Filter Element

A—Dust Cap/Cover
B—Primary Filter Element

C—Secondary Filter Element

RG11321A—UN—08SEP00

RG11322A—UN—08SEP00

RG11327A—UN—08SEP00

RG41165,000008B -19-07OCT10-1/1

Replacing Fan and Alternator Belts

Refer to CHECKING BELT TENSIONER SPRING TENSION AND BELT WEAR in Lubrication and Maintenance/250 Hour/6 Month Section for additional information on the belt tensioner.

1. Inspect belts for cracks, fraying, or stretched out areas. Replace if necessary.
2. To replace belt with automatic tensioner, release tension on belt using a breaker bar and socket (if required) on tension arm.

To replace belt with manual tensioner, release tension at belt tensioner (See MANUAL BELT TENSIONER ADJUSTMENT in Lubrication and Maintenance/250 Hour/6 Month Section.)

3. Remove poly-vee belt from pulleys and discard belt.
4. Install new belt, making sure belt is correctly seated in all pulley grooves. Refer to belt routing at right for your application.
5. Apply tension to belt with tensioner. Remove socket.
6. Start engine and check belt alignment.

*Measured from crank centerline to fan drive center.

A —Alternator	I — Idler Pulley
CSP —Crankshaft Pulley	T —Tensioner
FC —Freon (A/C) Compressor	CP —Coolant Pump
FD —Fan Drive	

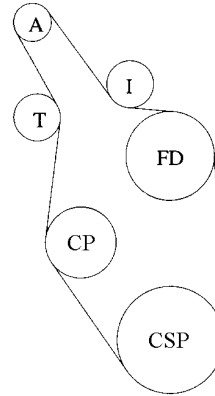

290 mm (11.4 in.) Fan Height and Lower*

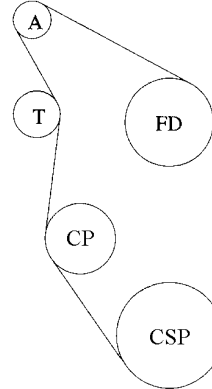

338 mm (13.3 in.) Fan Height and Higher Without Freon Compressor*

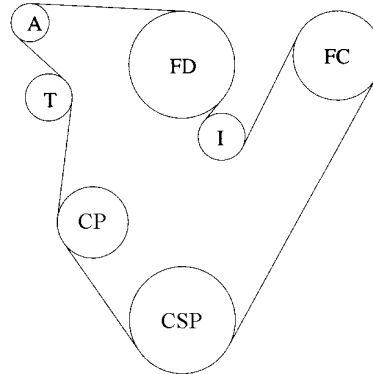

402 mm (15.8 in.) Fan Height With Freon Compressor*

OURGP12,000004C -19-29JUL04-1/1

RG11950—UN—07NOV01

RG11951—UN—07NOV01

RG11952—UN—07NOV01

Checking Fuses In Instrument Panels

The following instructions apply to engines equipped with John Deere instrument panels.

1. **On Engines With The North American Standard Instrument Panel (—1998)**, check the fuse (A) between the ammeter (B) and key switch (C) located on back side of instrument panel. If defective, replace with an equivalent 25-amp fuse.

Also check the fuse (D) mounted on the bottom of the magnetic safety switch. If defective, install an equivalent 14-amp fuse.

2. **On later (1999—) North American Standard Instrument Panels**, check the fuse in fuse holder (E) on front face of instrument panel. Replace as necessary with an equivalent 14-amp fuse.
3. **For VDO Instrument Panels**, the fuse is located on the electronic control card inside the panel's rear access cover. Remove cover and check fuse (F). If defective, replace with a 10-amp fuse. There is a spare fuse (G) available on the card in the "SPARE" terminal.

NOTE: For main electrical system fuses, see engine wiring diagrams later in this manual in Troubleshooting Section.

A—25 Amp Fuse
B—Ammeter
C—Key Switch
D—14 Amp Fuse

E—Fuse Holder
F—10 Amp Fuse
G—Spare Fuse

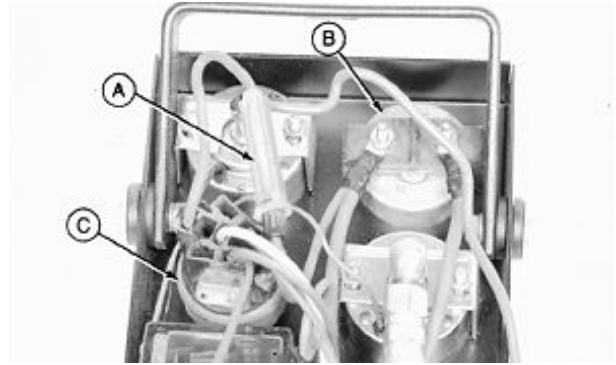

North American (—1998) Standard Instrument Panel Shown



North American (—1998) Standard Instrument Panel Shown

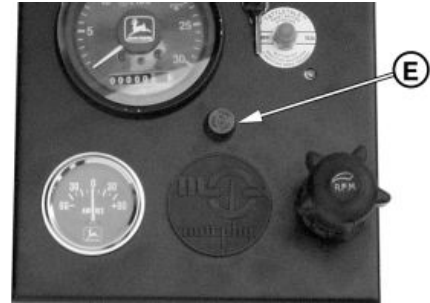

North American (1999—) Instrument Panel Shown

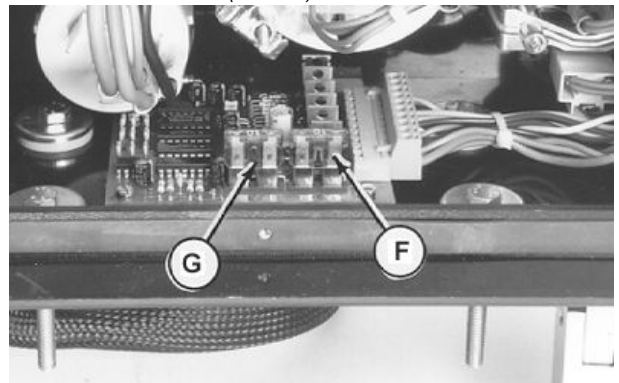

VDO Instrument Panel

RG, RG34710, 5601 -19-07JAN02-1/1

RG4493 —UN—14DEC88

RG4496A —UN—01JUN01

RG11937 —UN—17OCT01

RG12067 —UN—29JAN02

Checking Air Compressor (If Equipped)

Air compressors are offered as options with John Deere OEM engines to provide compressed air to operate air-powered devices like vehicle air brakes.

Air compressors are engine-driven piston types. They are either air cooled or cooled with engine coolant. The compressors are lubricated with engine oil. The compressor runs continuously as gear or spline driven by the auxiliary drive of the engine but has "loaded" and "unloaded" operating modes. This is controlled by the vehicle's air system (refer to vehicle technical manual for complete air system checks and services).

See your John Deere engine distributor or servicing dealer for diagnostic and troubleshooting information. If diagnosis leads to an internal fault in the compressor, replace the complete compressor as a new or remanufactured unit.

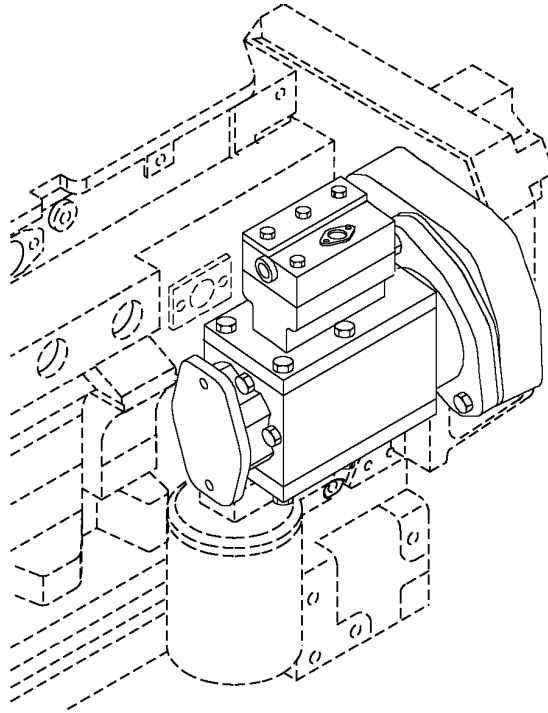

Air Compressor (Optional)

RG12836 — UN — 27FEB03

OURGP12,00001E0 -19-26FEB03-1/1

Bleeding the Fuel System

CAUTION: Escaping fluid under pressure can penetrate the skin causing serious injury. Relieve pressure before disconnecting fuel or other lines. Tighten all connections before applying pressure. Keep hands and body away from pinholes and nozzles which eject fluids under high pressure. Use a piece of cardboard or paper to search for leaks. Do not use your hand.

If ANY fluid is injected into the skin, it must be surgically removed within a few hours by a doctor familiar with this type injury or gangrene may result. Doctors unfamiliar with this type of injury may call the Deere & Company Medical Department in Moline, Illinois, or other knowledgeable medical source.

Bleed the fuel system anytime the fuel system has been opened up. This includes:

- After fuel filter changes.
- After injection pump or nozzle replacement.
- Anytime fuel lines have been disconnected.

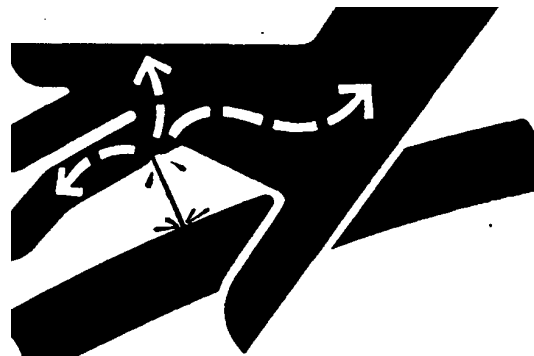

High-Pressure Fluids

- After engine has run out of fuel.

IMPORTANT: DO NOT pressurize fuel tank to push fuel through system, as the pressure can damage fuel injection pump seals

IMPORTANT: Do not operate the engine at high speeds or full loads just before bleeding the fuel system as this may cause fuel injection pump failure.

Continued on next page

OURGP11,000000D -19-18OCT06-1/7

X9811 — UN — 23AUG88

1. Loosen the air bleed vent screws (A) two full turns by hand on fuel filter base. (One screw with single filter option.)

A—Air Bleed Vent Screws



Air Bleed Vent Screws (Final Filter at Left, Primary Filter with Separator Bowl at Right)

OURGP11,000000D -19-18OCT06-2/7

RG13544 —UN—29JUL04

2. Operate supply pump primer lever (B) until fuel flow is free from air bubbles.
3. Tighten bleed plug securely, continue operating hand primer until pumping action is not felt. Push hand primer inward (toward engine) as far as it will go.
4. Start engine and check for leaks.

If engine will not start, it may be necessary to bleed air from fuel system at fuel injection pump or injection nozzles as explained next.

B—Fuel Supply Pump Primer Lever

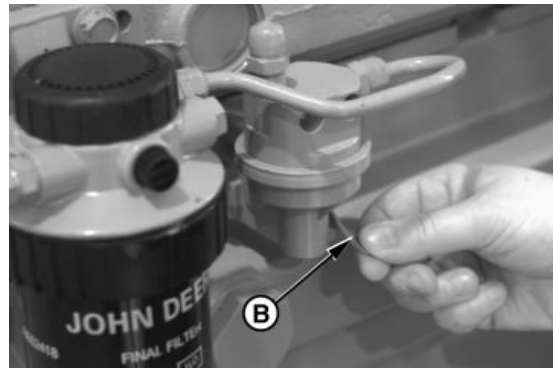

Fuel Supply Pump Primer Lever

OURGP11,000000D -19-18OCT06-3/7

RG8013A —UN—15JAN99

At Fuel Injection Pump

On Stanadyne rotary pumps:

1. Slightly loosen fuel return line connector (A) at fuel injection pump.
2. Operate fuel supply pump primer lever until fuel, without air bubbles, flows from fuel return line connection.
3. Tighten return line connector to 27 N·m (20 lb-ft).
4. Primer lever is spring-loaded and will return to normal position.

A—Fuel Return Line Connector

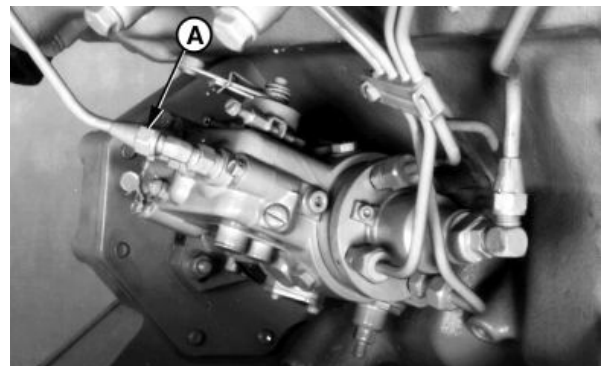

Stanadyne Rotary Fuel Injection Pump

Continued on next page

OURGP11,000000D -19-18OCT06-4/7

RG6264 —UN—03NOV97

On Lucas rotary pumps:

1. Loosen bleed screw (B) on pump cover.

NOTE: On Models DP200/201/203 Injection Pumps, bleed screw is located on top of cover near the fuel return line.

2. Operate fuel supply pump primer lever or turn ignition switch to "ON".
3. Wait until fuel flow is free of air bubbles. Tighten bleed screw.
4. Primer lever is spring loaded and will return to normal position.

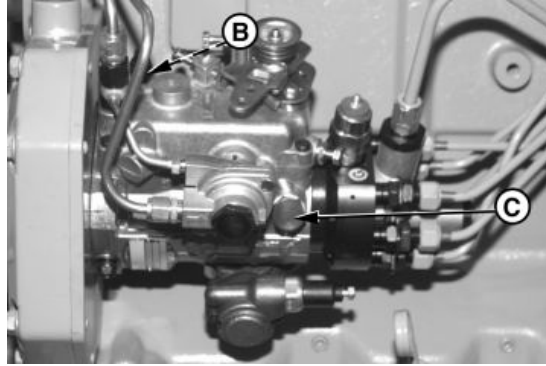

Lucas Rotary Fuel Injection Pumps

B—Bleed Screw

C—Screw

CAUTION: NEVER loosen screw (C) securing pump head, otherwise pump damage may occur.

OURGP11,000000D -19-18OCT06-5/7

RG7948 —JUN—13NOV97

On DENSO and Motorpal in-line pumps:

1. On DENSO pump shown, unscrew hand primer on fuel supply pump until it can be pulled by hand.
2. Open fuel filter port plug.
3. Operate the hand primer until a smooth flow of fuel, free of bubbles, comes out of the filter plug hole.
4. Simultaneously stroke the hand primer down and close the filter port plug. This prevents air from entering the system. Tighten plug securely. DO NOT overtighten.

IMPORTANT: Be sure hand primer is all the way down in barrel before tightening to prevent internal thread damage.

5. On DENSO pump shown, lock hand primer in position.

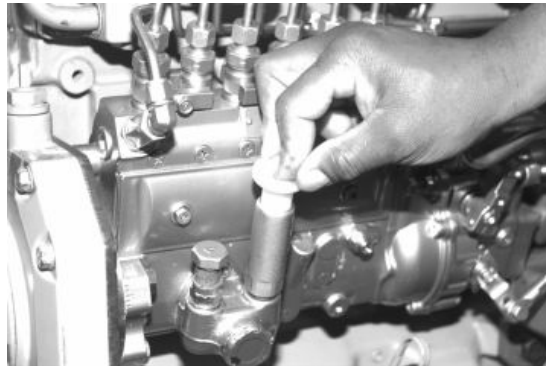

DENSO Fuel Injection Pump Shown

OURGP11,000000D -19-18OCT06-6/7

RG8069 —JUN—23NOV97

At Fuel Injection Nozzles

1. Move the engine speed control lever to half throttle position. On engines equipped with electronic fuel shut-off solenoid, energize solenoid.
2. Using **two** open-end wrenches, loosen fuel line connection at injection nozzle as shown.
3. Crank engine over with starter motor, (but do not start engine), until fuel free from bubbles flows out of loosened connection.
4. Retighten connection to 27 N-m (20 lb-ft).
5. Repeat procedure for remaining injection nozzles (if necessary) until all air has been removed from fuel system.



Fuel Line Connection

If engine still will not start, see your authorized servicing dealer or engine distributor.

OURGP11,000000D -19-18OCT06-7/7

RG7725 —JUN—08JAN97

Troubleshooting

General Troubleshooting Information

Troubleshooting engine problems can be difficult. An engine wiring diagram is provided in this section to help isolate electrical problems on power units using John Deere wiring harness and instrument (gauge) panel.

Wiring diagrams are shown for the two types of instrument panels offered for these engines.

Later in this section is a list of possible engine problems that may be encountered accompanied by possible causes and corrections. The illustrated diagrams and troubleshooting information are of a general nature, final design of the overall system for your engine application may be different. See your engine distributor or servicing dealer if you are in doubt.

A reliable program for troubleshooting engine problems should include the following basic diagnostic thought process:

- Know the engine and all related systems.
- Study the problem thoroughly.
- Relate the symptoms to your knowledge of engine and systems.
- Diagnose the problem starting with the easiest things first.
- Double-check before beginning the disassembly.
- Determine cause and make a thorough repair.
- After making repairs, operate the engine under normal conditions to verify that the problem and cause was corrected.

RG, RG34710, 5605 -19-07 JAN02-1/1

Engine Wiring Diagram Legend (Standard Instrument Panel For North America)

A1 — Speed Control Unit	P6 — Ammeter
B1 — Magnetic Speed Sensor	R1 — Resistor (48 ohm) ³
B2 — Coolant Temperature Sensor	S1 — Key Switch
B3 — Oil Pressure Sensor	S2 — Magnetic Safety Switch—North American Auto Override Module—European (Saran)
F1 — Starting Circuit Fuse (14 amp)	W1 — Ground on K1 Starter Relay Mounting Stud
F3 — Fuse (Early Models) ¹	Y1 — Starter Solenoid
G1 — Battery	Y2 — Fuel Shut-off Solenoid
G2 — Alternator	BLK — Black
H1 — Coolant Temperature Indicator Lamp	BLU — Blue
H2 — Oil Pressure Indicator Lamp	BRN — Brown
H3 — Alternator Indicator Lamp	DK BLU — Dark Blue
K1 — Starter Relay	GRN — Green
M1 — Starter Motor	ORG — Orange
P1 — Coolant Temperature Gauge	PUR — Purple
P2 — Oil Pressure Gauge	RED — Red
P3 — Crankcase Oil Level Switch/Gauge	YEL — Yellow
P4 — Tachometer ¹	
P5 — Hourmeter (Early Models) ²	

¹ P4 tachometer has a built-in hourmeter. On some earlier engines, a separate hourmeter (P5) and fuse (F3) were used.

² P4 tachometer has a built-in hourmeter. On some engines, a separate hourmeter (P5) and fuse (F3) are used.

³ Later harnesses have two parallel 100 ohm resistors for the alternator.

Wiring Diagram (Standard Instrument Panel For North America)

S1 KEY SWITCH					
	B	G	ACC.	ON	ST.
OFF					
ACC.	•		•		
ON	•		•	•	
START	•	•		•	•

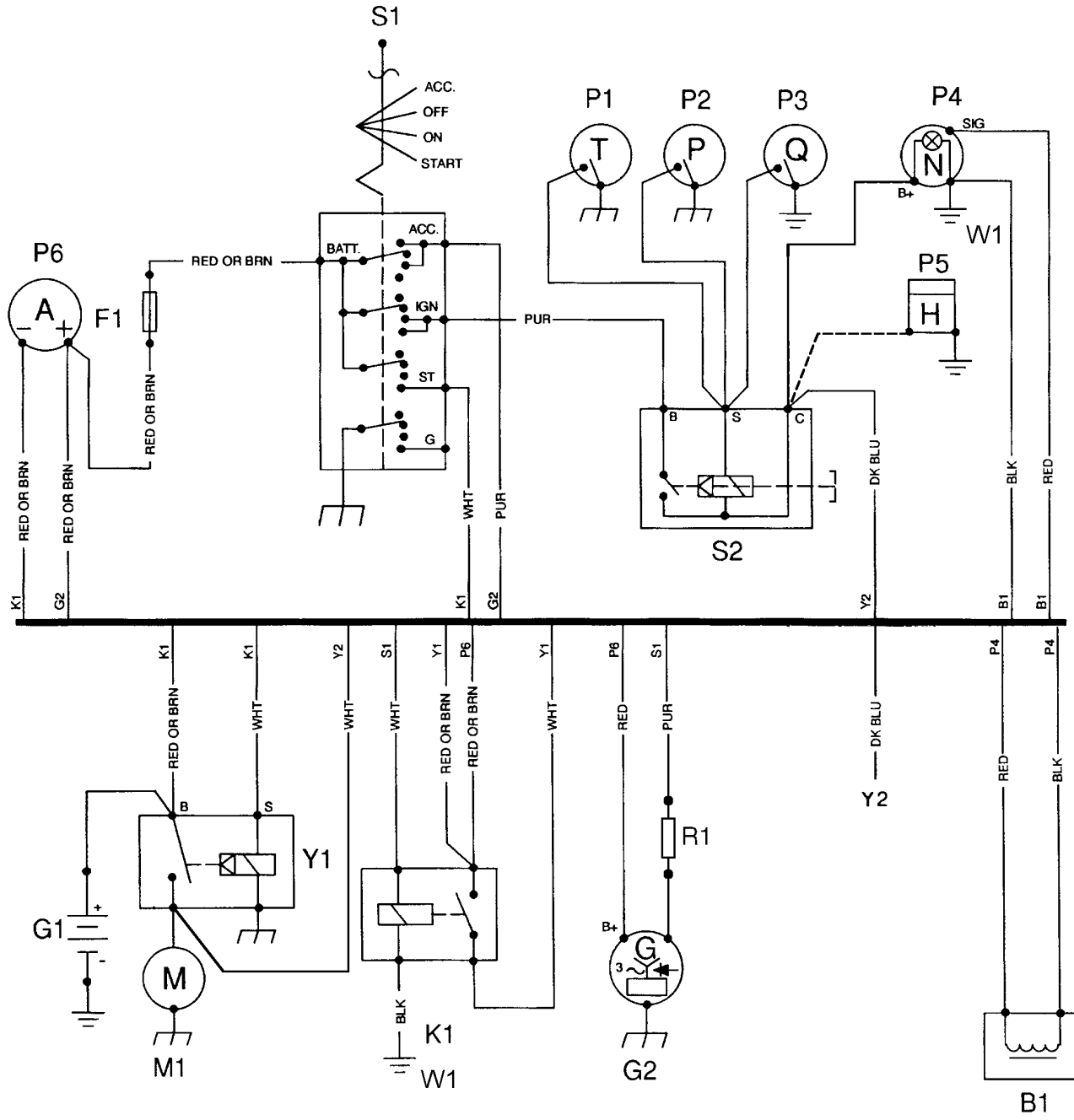

RG11329—UN—13SEP00

DPSG, RG41165, 127 -19-19JUN00-1/1

Engine Wiring Diagram—VDO Instrument Panel (Except North America)

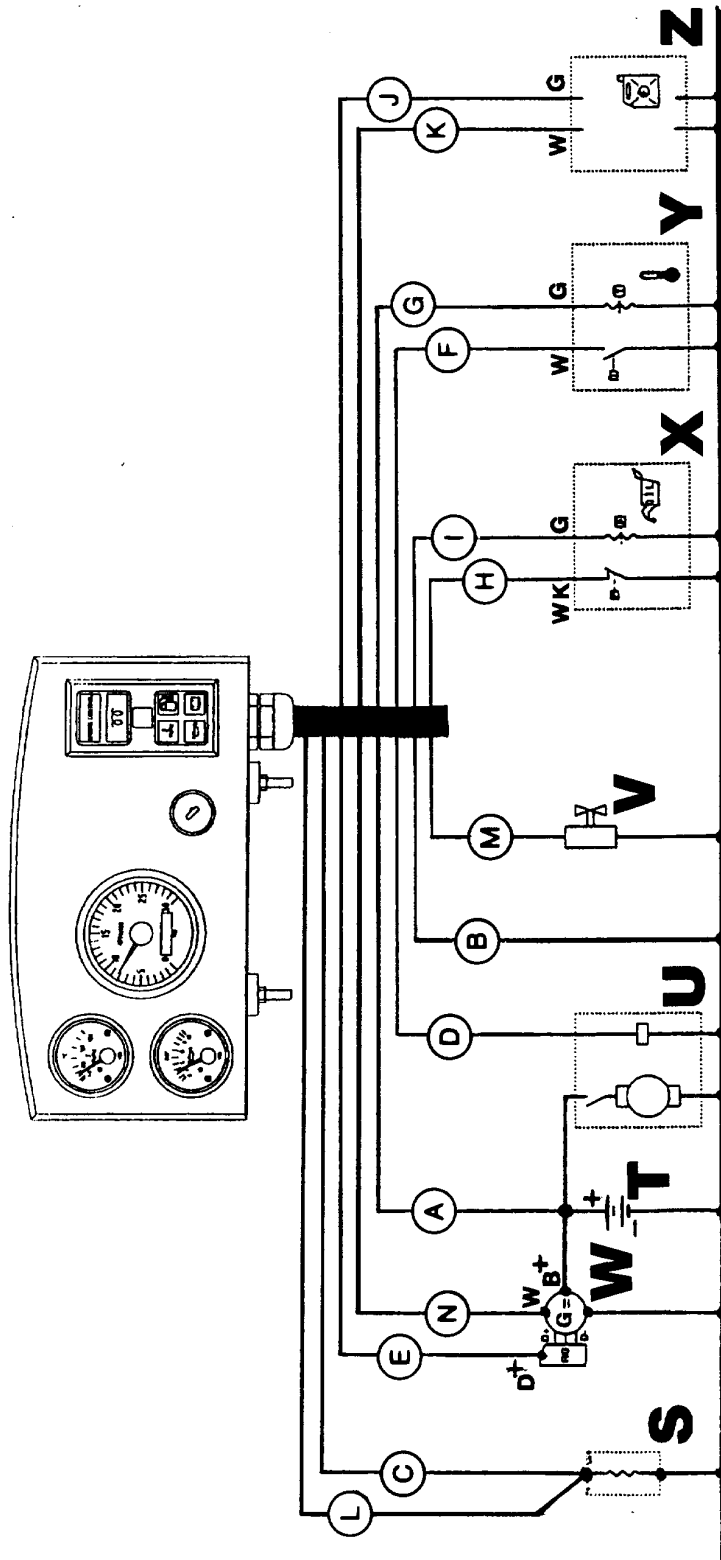

DPSG, RG41165, 131 -19-19JUN00-1/1

CD623P5 —UN—13NOV98

Engine Wiring Diagram Legend—VDO Instrument Panel (Except North America)

A — 6 mm ² , Red	M — 0.75 mm ² , Green/Yellow
B — 1.5 mm ² , Black	N — 0.75 mm ² , Red
C — 6 mm ² , Blue	O—R — Not Used
D — 4 mm ² , Black	S — Preheater
E — 0.75 mm ² , Orange	T — Battery
F — 0.75 mm ² , White	U — Starter Motor
G — 0.75 mm ² , Blue	V — Electrical Shut-Off
H — 0.75 mm ² , Purple	W — Alternator
I — 0.75 mm ² , Grey	X — Oil Pressure Sensor
J — 0.75 mm ² , Brown	Y — Coolant Temperature Sensor
K — 0.75 mm ² , Dark Blue	Z — Fuel Tank Gauge
L — 0.75 mm ² , Black	

DPSG, RG41165, 129 -19-19JUN00-1/1

Engine Troubleshooting

Symptom	Problem	Solution
Engine cranks but will not start	Incorrect starting procedure.	Verify correct starting procedure.
	No fuel.	Check fuel in tank and manual shut-off valve.
	Exhaust restricted.	Check and correct exhaust restriction.
	Fuel filter plugged or full of water.	Replace fuel filter or drain water from filter.
	Injection pump not getting fuel or air in fuel system.	Check fuel flow at supply pump or bleed fuel system.
	Faulty injection pump or nozzles.	Consult authorized diesel repair station for repair or replacement.
Engine hard to start or will not start	Engine starting under load.	Disengage driveline.
	Improper starting procedure.	Review starting procedure.
	No fuel.	Check fuel tank.
	Air in fuel line.	Bleed fuel line.
	Cold weather.	Use cold weather starting aids.
	Slow starter speed.	See "Starter Cranks Slowly".
	Crankcase oil too heavy.	Use oil of proper viscosity.
	Improper type of fuel.	Consult fuel supplier; use proper type fuel for operating conditions.
	Water, dirt, or air in fuel system.	Drain, flush, fill, and bleed system.
	Clogged fuel filter.	Replace filter element.
	Dirty or faulty injection nozzles.	Have authorized servicing dealer or engine distributor check injectors.
	Injection pump shut-off not reset.	Turn key switch to "OFF" then to "ON".
	Engine knocks	Low engine oil level.
Injection pump out of time.		See your authorized servicing dealer or engine distributor.
Low coolant temperature.		Remove and check thermostat.
Engine overheating.		See "Engine Overheats".

Continued on next page

OUOD006,000004C -19-13OCT06-1/5

Troubleshooting

Symptom	Problem	Solution
Engine runs irregularly or stalls frequently	Low coolant temperature.	Remove and check thermostat.
	Clogged fuel filter.	Replace fuel filter element.
	Water, dirt, or air in fuel system.	Drain, flush, fill, and bleed system.
	Poor quality fuel.	Change to better quality fuel.
	Dirty or faulty injection nozzles.	Have authorized servicing dealer or engine distributor check injectors.
Below normal engine temperature	Defective thermostat.	Remove and check thermostat.
	Defective temperature gauge or sender.	Check gauge, sender, and connections.
Lack of power	Engine overloaded.	Reduce load.
	Intake air restriction.	Service air cleaner.
	Clogged fuel filter.	Replace filter elements.
	Improper type of fuel.	Use proper fuel.
	Overheated engine.	See "Engine Overheats".
	Below normal engine temperature.	Remove and check thermostat.
	Improper valve clearance.	See your authorized servicing dealer or engine distributor.
	Dirty or faulty injection nozzles.	Have authorized servicing dealer or engine distributor check injectors.
	Injection pump out of time.	See your authorized servicing dealer or engine distributor.
	Turbocharger not functioning. (Turbocharger engines only.)	See your authorized servicing dealer or engine distributor.
	Leaking exhaust manifold gasket.	See your authorized servicing dealer or engine distributor.
	Defective aneroid control line.	See your authorized servicing dealer or engine distributor.
	Restricted fuel hose.	Clean or replace fuel hose.
	Low fast idle speed.	See your authorized servicing dealer or engine distributor.
Low oil pressure	Low oil level.	Add oil.

Continued on next page

OUOD006,000004C -19-13OCT06-2/5

Troubleshooting

Symptom	Problem	Solution
High oil consumption	Improper type of oil.	Drain, fill crankcase with oil of proper viscosity and quality.
	Crankcase oil too light.	Use proper viscosity oil.
	Oil leaks.	Check for leaks in lines, gaskets, and drain plug.
	Restricted crankcase vent tube.	Clean vent tube.
Engine emits white smoke	Defective turbocharger.	See your authorized servicing dealer or engine distributor.
	Improper type of fuel.	Use proper fuel.
	Low engine temperature.	Warm up engine to normal operating temperature.
	Defective thermostat.	Remove and check thermostat.
	Defective injection nozzles.	See your authorized servicing dealer or engine distributor.
Engine emits black or gray exhaust smoke	Engine out of time.	See your authorized servicing dealer or engine distributor.
	Improper type of fuel.	Use proper fuel.
	Clogged or dirty air cleaner.	Service air cleaner.
	Engine overloaded.	Reduce load.
	Injection nozzles dirty.	See your authorized servicing dealer or engine distributor.
	Engine out of time.	See your authorized servicing dealer or engine distributor.
Engine overheats	Turbocharger not functioning.	See your authorized servicing dealer or engine distributor.
	Engine overloaded.	Reduce load.
	Low coolant level.	Fill radiator to proper level, check radiator and hoses for loose connections or leaks.
	Faulty radiator cap.	Have serviceman check.
	Stretched poly-vee belt or defective belt tensioner.	Check automatic belt tensioner and check belts for stretching. Replace as required.

Continued on next page

OUOD006,000004C -19-13OCT06-3/5

Troubleshooting

Symptom	Problem	Solution
	Low engine oil level.	Check oil level. Add oil as required.
	Cooling system needs flushing.	Flush cooling system.
	Defective thermostat.	Remove and check thermostat.
	Defective temperature gauge or sender.	Check water temperature with thermometer and replace, if necessary.
	Incorrect grade of fuel.	Use correct grade of fuel.
High fuel consumption	Improper type of fuel.	Use proper type of fuel.
	Clogged or dirty air cleaner.	Service air cleaner.
	Engine overloaded.	Reduce load.
	Improper valve clearance.	See your authorized servicing dealer or engine distributor.
	Injection nozzles dirty.	See your authorized servicing dealer or engine distributor.
	Engine out of time.	See your authorized servicing dealer or engine distributor.
	Defective turbocharger.	See your authorized servicing dealer or engine distributor.
	Low engine temperature.	Check thermostat.
Undercharged electrical system	Excessive electrical load from added accessories.	Remove accessories or install higher output alternator.
	Excessive engine idling.	Increase engine rpm when heavy electrical load is used.
	Poor electrical connections on battery, ground strap, starter, or alternator.	Inspect and clean as necessary.
	Defective battery.	Test battery.
	Defective alternator.	Test charging system.
Battery uses too much water	Cracked battery case.	Check for moisture and replace as necessary.
	Defective battery.	Test battery.
	Battery charging rate too high.	Test charging system.
Batteries will not charge	Loose or corroded connections.	Clean and tighten connections.

Continued on next page

OUOD006,000004C -19-13OCT06-4/5

Troubleshooting

Symptom	Problem	Solution
Starter will not crank	Sulfated or worn-out batteries.	See your authorized servicing dealer or engine distributor.
	Stretched poly-vee belt or defective belt tensioner.	Adjust belt tension or replace belts.
	Engine driveline engaged.	Disengage engine driveline.
	Loose or corroded connections.	Clean and tighten loose connections.
	Low battery output voltage.	See your authorized servicing dealer or engine distributor.
Starter cranks slowly	Faulty start circuit relay.	See your authorized servicing dealer or engine distributor.
	Blown main system fuse (MDL-25)	Replace fuse.
	Low battery output.	See your authorized servicing dealer or engine distributor.
Starter and hour meter functions; rest of electrical system does not function	Crankcase oil too heavy.	Use proper viscosity oil.
	Loose or corroded connections.	Clean and tighten loose connections.
	Blown fuse on magnetic switch.	Replace fuse.
	Entire electrical system does not function	Faulty battery connection.
Sulfated or worn-out batteries.		See your authorized servicing dealer or engine distributor.
Blown main system fuse (MDL-25).		Replace fuse.

OUOD006,000004C -19-13OCT06-5/5

Storage

Engine Storage Guidelines

IMPORTANT: Special considerations should be taken prior to storage when using BioDiesel. See BioDiesel Fuel in the Fuels, Lubricants, and Coolant Section.

1. John Deere engines can be stored outside for up to three months with no long-term preparation if covered by a waterproof covering. No outside storage is recommended without a waterproof covering.
2. John Deere engines can be stored in a standard overseas shipping container for up to three months with no long-term preparation.
3. John Deere engines can be stored inside for up to six months with no long-term preparation.
4. John Deere engines expected to be stored more than six months **must** have long-term storage preparation. See [Preparing Engine for Long-Term Storage](#) in the Storage Section.

OURGP12.00000DF -19-04FEB15-1/1

Preparing Engine for Long-Term Storage

IMPORTANT: Any time the engine is not used for over six months, the following recommendations for storing it and removing it from storage helps to minimize corrosion and deterioration.

IMPORTANT: Long-term storage is not advised when using BioDiesel. For storage longer than one year, use straight hydrocarbon fuel.

If BioDiesel must be used it is recommended the blend not exceed B7 and a high-quality fuel stabilizer be used. Storage should not exceed one year.

For more information see BioDiesel Fuel in the Fuels, Lubricants, and Coolants Section.

NOTE: The following storage preparations are used for long-term engine storage up to one year. After that, the engine should be started, warmed up, and retreated for an extended storage period.

1. Change engine oil and replace filter. Used oil does not give adequate protection. Add 30 mL of rust preventive oil to the engine crankcase for every 1 L of engine oil, or 1 oz. of rust preventative oil per 1 qt. of engine oil. This rust preventive oil should be an SAE 10W oil with 1%-4% morpholine or equivalent vapor corrosion inhibitor, such as NOX RUST VCI-10 OIL from Daubert Chemical Company, Inc.
2. Replace air cleaner.
3. Draining and flushing of cooling system is not necessary if the engine is only stored for less than one year. However, for extended storage periods of a year or longer, it is recommended that the cooling system be drained, flushed, and refilled. Refill with appropriate coolant. See [Diesel Engine Coolant \(engine with wet sleeve cylinder liners\)](#) in the Fuels, Lubricants, and Coolants Section.
4. Prepare a solution of diesel fuel and rust preventive oil in a temporary container, add 78 mL of rust preventive oil per 1 L of diesel fuel, 10 oz. of rust preventive oil per 1 gal. of diesel fuel.
5. Remove existing lines and plugs as required. Run a temporary line from the temporary container to the engine fuel intake before the fuel filters, and another temporary line from the fuel return to the temporary container, so rust preventive oil solution is circulated through the injection system during cranking.
IMPORTANT: Do not operate starter more than 30 seconds at a time. Wait at least 2 minutes for starter to cool before trying again.
6. Crank the engine several revolutions with starter. Do not allow the engine to start. This allows rust preventive oil solution to circulate.
See your authorized dealer for the proper procedure for your application.
7. Remove temporary lines installed in Step 5 and replace any lines or plugs previously removed.
8. Loosen (or remove) and store fan and alternator poly-vee belt.
9. Remove and clean batteries. Store them in a cool, dry place and keep them fully charged.
10. Disengage the clutch for any driveline.
11. Clean the exterior of the engine with salt-free water and touch up any scratched or chipped painted surfaces with a good quality paint.
12. Coat all exposed bare metal surfaces with grease or corrosion inhibitor if not feasible to paint.
13. Seal all openings on engine with plastic bags and tape.
14. Store the engine in a dry protected place. If engine must be stored outside, cover it with a waterproof canvas or other suitable protective material and use a strong waterproof tape.

OUOD006.00000FC -19-28APR16-1/1

Removing Engine from Long Term Storage

Refer to the appropriate section for detailed services listed below or have your authorized servicing dealer or engine distributor perform services that you may not be familiar with.

1. Remove all protective coverings from engine. Unseal all openings in engine and remove covering from electrical systems.
2. Remove the batteries from storage. Install batteries (fully charged) and connect the terminals.
3. Install fan/alternator poly-vee belt if removed.
4. Fill fuel tank.
5. Perform all appropriate prestarting checks. (See DAILY PRESTARTING CHECKS in Lubrication and Maintenance/Daily Section.)

IMPORTANT: DO NOT operate starter more than 30 seconds at a time. Wait at least 2 minutes for starter to cool before trying again.

6. Crank engine for 20 seconds with starter (do not allow the engine to start). Wait 2 minutes and crank engine an additional 20 seconds to assure bearing surfaces are adequately lubricated.
7. Start engine and run at low idle and no load for several minutes. Warm up carefully and check all gauges before placing engine under load.
8. On the first day of operation after storage, check overall engine for leaks and check all gauges for correct operation.

NOTE: If using BIODIESEL blends after long term storage, frequency of fuel filter plugging may increase initially.

OUOD006,00000FD -19-02OCT07-1/1

Specifications

General OEM Engine Specifications — 4.5 L Engines

ITEM	4045 (4.5 L) (Naturally Aspirated)	4045 (4.5 L) (Turbocharged)
Number of Cylinders	4	4
Bore	106 mm (4.19 in.)	106 mm (4.19 in.)
Stroke	127 mm (5.0 in.)	127 mm (5.0 in.)
Displacement	4.5 L (276 cu in.)	4.5 L (276 cu in.)
Compression Ratio	17.6:1	17.0:1
Max. Crank Pressure	0.5 kPa (2 H ₂ O)	0.5 kPa (2 H ₂ O)
Governor Regulation (Industrial)	7—10 %	7—10 %
Governor Regulation (Generator)	5 %	5 %
Oil Pressure, Rated Speed, Full Load (±15 psi)	345 kPa (50 psi)	345 kPa (50 psi)
Oil Pressure, Low Idle (Minimum)	105 kPa (15 psi)	105 kPa (15 psi)
Length ^a	844.0 mm (33.2 in.)	861.0 mm (33.9 in.)
Width ^a	550 mm (21.7 in.)	598 mm (23.5 in.)
Height ^a	871 mm (34.3 in.)	980 mm (38.6 in.)
Weight ^a	429 kg (945 lb)	396 kg (872 lb)

^aMeasurement may vary depending on installed options

OURGP12.0000041 -19-20AUG15-1/1

General OEM Engine Specifications — 6.8 L Engines

ITEM	6068 (6.8 L) (Naturally Aspirated)	6068 (6.8 L) (Turbocharged)
Number of Cylinders	6	6
Bore	106 mm (4.19 in.)	106 mm (4.19 in.)
Stroke	127 mm (5.0 in.)	127 mm (5.0 in.)
Displacement	6.8 L (414 cu in.)	6.8 L (414 cu in.)
Compression	17.6:1	17.0:1
Max. Crank Pressure	0.5 kPa (2 H ₂ O)	0.5 kPa (2 H ₂ O)
Governor Regulation (Industrial)	7—10 %	7—10 %
Governor Regulation (Generator)	5 %	5%
Oil Pressure At Rated Speed, Full Load (±15 psi)	345 kPa (50 psi)	345 kPa (50 psi)
Oil Pressure At Low Idle (Minimum)	105 kPa (15 psi)	105 kPa (15 psi)
Length ^a	1117 mm (44.0 in.)	1141 mm (44.9 in.)
Width ^a	598 mm (23.5 in.)	623 mm (24.5 in.)
Height ^a	956 mm (37.6 in.)	1009 mm (39.7 in.)
Weight ^a	522 kg (1149 lb)	568 kg (1250 lb)

^aMeasurement may vary depending on installed options

OURGP12.0000042 -19-20AUG15-1/1

Engine Power Ratings And Fuel Injection Pump Specifications — 4.5 L Engines

NOTE: The power specifications shown below apply to Dubuque, Torreon and Saran-built OEM engines. Specifications are subject to change. Refer to factory DTAC for assistance.

Engine speeds listed are as preset to factory specification. In most cases, slow idle speed will be reset depending upon specific vehicle

application requirements. Refer to your machine technical manual for engine speeds that are different from those preset at the factory.

Power ratings specify flywheel power for a bare engine without the drag effect of a cooling fan or other accessories like an air compressor.

POWER RATINGS ON DYNAMOMETER FOR OEM ENGINES

Injection Pump Option Code	Original Injection Pump (Part No.)	Replaced By Injection Pump (Part No.)	Governor Regulation	Rated Speed (rpm) At Full Load	Slow Idle (rpm)	No Load Fast Idle (rpm)	Power Rating kW (HP)
1601	RE61649	RE67557	STD	2500	850	2700	60 (80)
1601	RE67557		STD	2500	850	2700	60 (80)
1602	RE59809		STD	2500	850	2700	63 (85)
1603	RE63555	RE67558	3—5%	1800	1150	1870	53 (71)
1603	RE67558	RE505070	3—5%	1800	1150	1870	53 (71)
1603	RE505070	RE506132	3—5%	1800	1150	1870	53 (71)
1603	RE506132		3—5%	1800	1150	1870	53 (71)
1605	RE61668	RE69781	STD	2500	850	2700	86 (115)
1605	RE69781		STD	2500	850	2700	86 (115)
1606	RE64133	RE505927	STD	2400	850	2600	93 (125)
1606	RE505927		STD	2400	850	2600	93 (125)
1608	RE67564		3—5%	1800	1400	1870	84 (113)
1610	RE68826	RE505928	STD	2400	850	2600	104 (140)
1611	RE60237		3—5%	1800	1400	1870	95 (127)
1656	RE63610	RE67562	3—5%	1800	1150	1870	75 (100)
1656	RE67562		3—5%	1800	1150	1870	75 (100)
1663	RE71089	RE500949	STD	2500	1600	2700	60 (80)
1663	RE500949		STD	2500	1600	2700	60 (80)
1667	RE59968		STD	2400	850	2600	93 (125)
1675	RE60091	RE69782	STD	2500	850	2700	86 (115)
1675	RE69782		STD	2500	850	2700	86 (115)
1676	RE60093	RE61668	STD	2500	850	2700	86 (115)
1676	RE61668		STD	2500	850	2700	86 (115)
1677	RE60096	RE67563	3—5%	1800	1150	1870	75 (100)
1677	RE67563		3—5%	1800	1150	1870	75 (100)
1671	RE67559	RE502714	STD	2500	850	2700	60 (80)
1671	RE502714		STD	2500	850	2700	60 (80)
1673	RE60085	RE67560	3—5%	1800	1400	1870	53 (71)
1673	RE67560	RE506130	3—5%	1800	1400	1870	53 (71)
1673	RE506130		3—5%	1800	1400	1870	53 (71)
1674	RE60089	RE67561	3—5%	1800	1400	1870	53 (71)
1674	RE67561	RE506131	3—5%	1800	1400	1870	53 (71)
1674	RE506131		3—5%	1800	1400	1870	53 (71)
1677	RE60096	RE67563	3—5%	1800	850	1870	75 (100)
1677	RE67563		3—5%	1800	850	1870	75 (100)
1682	RE67566		3—5%	1800	1400	1870	84 (113)
1683	RE60124	RE505926	STD	2400	850	2600	93 (125)
1683	RE505926		STD	2400	850	2600	93 (125)
1691	RE61649	RE500831	STD	2500	850	2700	60 (80)
1691	RE500831	RE500948	STD	2500	850	2700	60 (80)

Continued on next page

BL90236,0000001 -19-01SEP15-1/4

Specifications

POWER RATINGS ON DYNAMOMETER FOR OEM ENGINES

Injection Pump Option Code	Original Injection Pump (Part No.)	Replaced By Injection Pump (Part No.)	Governor Regulation	Rated Speed (rpm) At Full Load	Slow Idle (rpm)	No Load Fast Idle (rpm)	Power Rating kW (HP)
1691	RE500948		STD	2500	850	2700	60 (80)
1692	RE61668	RE500881	STD	2500	1400	2700	86 (115)
1692	RE500881	RE502416	STD	2500	1400	2700	86 (115)
1692	RE502416		STD	2500	1400	2700	86 (115)
1694	RE67863	RE69779	STD	2500	850	2700	75 (100)
1694	RE69779		STD	2500	850	2700	75 (100)
1695	RE69739	RE69780	STD	2500	850	2700	75 (100)
1695	RE69780		STD	2500	850	2700	75 (100)
160B	RE68827		3—5%	1800	1400	1870	95 (127)
160C	RE69588	RE505959	STD	2400	850	2600	104 (140)
160R	RE70941		3—5%	1800	1400	1870	84 (113)
161A	RE509525		STD	2100	850	2200	107 (143)
161B	RE509526		STD	2100	850	2200	107 (143)
161C	RE507525	RE506881	3—5%	1800	1400	1870	100 (134)
161D	RE507526	RE506882	3—5%	1800	1400	1870	100 (134)
163Z	RE505927		STD	2400	850	2600	93 (125)
165D	RE506989		3—5%	1500	—	1560	70 (94)
165E	RE506990		3—5%	1500	—	1560	70 (94)
165F	RE503729		3—5%	1500	—	1560	44 (59)
165G	RE504693		3—5%	1500	—	1560	44 (59)
165W	RE500949		STD	2500	1600	2700	60 (80)
168Q	RE521143		3—5%	1500	—	1560	83 (111)
168R	RE522388		3—5%	1500	—	1560	83 (111)
169E	RE522414		3—5%	3000	850	3120	152 (204)
169F	RE522698		3—5%	3000	850	3120	152 (204)
169P	RE522714		3—5%	3000	850	3120	119 (160)
169Q	RE522697		3—5%	3000	850	3120	119 (160)
16AB	RE69779		STD	2500	850	2700	75 (100)
16AX	RE500551		STD	2400	850	2600	76 (102)
16AY	RE500505		STD	2400	850	2600	62 (83)
16BF	RE500848		STD	2200	950	2400	73 (98)
16BG	RE69778	RE502712	STD	2500	850	2700	63 (85)
16BG	RE502712		STD	2500	850	2700	63 (85)
16BH	RE500873	RE502715	STD	2500	850	2700	63 (85)
16BH	RE502715		STD	2500	850	2700	63 (85)
16BJ	RE500589		STD	2250	850	2450	36 (48)
16CE	RE501180		STD	2500	850	2700	75 (100)
16CL	RE501364	RE502713	STD	2200	950	2400	58 (78)
16CL	RE502713		STD	2200	950	2400	58 (78)
16CM	RE501365		STD	2200	950	2400	66.6 (89)
16CU	RE501192		STD	2200	850	2400	79.5 (107)
16CV	RE501346		STD	2200	950	2400	85 (114)
16DL	RE70452		STD	2400	850	2600	61 (82)
16EN	RE502019		STD	2500	850	2700	60 (80)
16GB	RE502711		STD	2500	850	2700	60 (80)
16GB	RE502711		STD	2500	850	2700	60 (80)
16GC	RE502716		STD	2500	850	2700	60 (80)
16GL	RE502706		STD	2300	850	2500	78 (105)
16GQ	RE503048	RE506544	3—5%	1500	—	1560	83 (111)

Continued on next page

BL90236.0000001 -19-01SEP15-2/4

Specifications

POWER RATINGS ON DYNAMOMETER FOR OEM ENGINES

Injection Pump Option Code	Original Injection Pump (Part No.)	Replaced By Injection Pump (Part No.)	Governor Regulation	Rated Speed (rpm) At Full Load	Slow Idle (rpm)	No Load Fast Idle (rpm)	Power Rating kW (HP)
16GQ	RE506544		3—5%	1500	—	1560	83 (111)
16GR	RE503050	RE506965	3—5%	1500	—	1560	102 (137)
16GR	RE503050	RE506965	3—5%	1500	—	1560	102 (137)
16HJ	RE500948		STD	2500	1400	2700	60 (80)
16HK	RE500949		STD	2500	1600	2700	60 (80)
16HV	RE503258		STD	2250	850	2450	36 (48)
16JS	RE500505		STD	2400	850	2600	62 (83)
16JT	RE500551		STD	2400	850	2600	76 (102)
16KE	RE503560		STD	2500	850	2700	52 (70)
16LM	RE502711		STD	2500	850	2700	53 (71)
16LN	RE67558	RE505070	3—5%	1800	1150	1870	53 (71)
16LN	RE505070	RE506132	3—5%	1800	1150	1870	53 (71)
16LN	RE506132		3—5%	1800	1150	1870	53 (71)
16LP	RE67562		3—5%	1800	1150	1870	75 (100)
16LQ	RE67564		3—5%	1800	1400	1870	84 (113)
16LV	RE503830	RE506545	3—5%	1500	—	1560	83 (111)
16LV	RE506545		3—5%	1500	—	1560	83 (111)
16LZ	RE503735		3—5%	1800	—	1870	82 (110)
16LW	RE503832	RE506966	3—5%	1500	—	1560	102 (137)
16LW	RE506966		3—5%	1500	—	1560	102 (137)
16LZ	RE503735		3—5%	1800	1400	1870`	70 (94)
16MA	RE504696	RE504931	3—5%	1800	1400	1870	82 (110)
16MA	RE504931		3—5%	1800	1400	1870	82 (110)
16MB	RE503737		3—5%	1800	1400	1870	91(122)
16MC	RE504932		3—5%	1800	1400	1870	91 (122)
16ME	RE503739		3—5%	1800	1400	1870	123 (165)
16MF	RE504698	RE504966	3—5%	1800	1400	1870	123 (170)
16MF	RE504966		3—5%	1800	1400	1870	123 (170)
16MR	RE504463		STD	2500	850	2700	63 (85)
16MS	RE504464		STD	2500	850	2700	63 (85)
16MT	RE503733	RE505050	3—5%	1500	1400	1560	70 (94)
16MT	RE505050		3—5%	1500	1400	1560	70 (94)
16MT	RE503733	RE506989	3—5%	1500	—	1560	70 (94)
16MT	RE506989		3—5%	1500	—	1560	70 (94)
16MU	RE504695	RE505050	3—5%	1500	—	1560	70 (94)
16MU	RE505050	RE506990	3—5%	1500	—	1560	70 (94)
16MU	RE506990		3—5%	1500	—	1560	70 (94)
16MV	RE503736		3—5%	1800	1400	1870	100 (134)
16MW	RE504682		3—5%	1800	1400	1870	100 (134)
16NH	RE505411		3—5%	1800	1150	2240	75 (100)
16NT	RE504465		STD	2500	850	2700	86 (115)
16NU	RE504466		STD	2500	850	2700	86 (115)
16PZ	RE500848		STD	2200	850	2400	73 (98)
16QZ	RE503050		3—5%	1800	1400	1870	111 (149)
16RA	RE503832		3—5%	1800	1400	1870	111 (149)
16RB	RE503729		3—5%	1500	—	1560	44 (59)
16RC	RE504693		3—5%	1500	—	1560	44 (59)
16RM	RE505959		STD	2400	850	2600	104 (140)
16TE	RE507257		STD	2400	850	2600	85 (114)

Continued on next page

BL90236,0000001 -19-01SEP15-3/4

Specifications

POWER RATINGS ON DYNAMOMETER FOR OEM ENGINES

Injection Pump Option Code	Original Injection Pump (Part No.)	Replaced By Injection Pump (Part No.)	Governor Regulation	Rated Speed (rpm) At Full Load	Slow Idle (rpm)	No Load Fast Idle (rpm)	Power Rating kW (HP)
16TG	RE507941		STD	2000	850	2185	77 (103)
16YJ	RE508834		STD	2000	850	2185	77 (103)
16YU	RE508754		3—5%	1800	—	1870	75 (101)
16ZC	RE518780		STD	2200	950	2400	66 (89)
16ZW (Naturally aspirated)	RE509527		3—5%	2500	850	2700	63 (85)
16ZW	RE509527		3—5%	1500	1400	1560	70 (94)
16ZX (Naturally aspirated)	RE509528		3—5%	2500	850	2700	63 (85)
16ZX	RE509528		3—5%	1500	1400	1560	70 (94)
16ZY (Naturally aspirated)	RE509529		3—5%	2500	850	2700	63 (85)
16ZY	RE509529		3—5%	1500	1400	1560	70 (94)
16ZZ	RE508613		STD	2100	850	2200	107 (143)

BL90236.0000001 -19-01SEP15-4/4

Engine Power Ratings And Fuel Injection Pump Specifications — 6.8 L Engines

NOTE: The power specifications shown below apply to Dubuque, Torreon and Saran-built OEM engines. Specifications are subject to change. Refer to factory DTAC for assistance.

Engine speeds listed are as preset to factory specification. In most cases, slow idle speed will be reset depending upon specific vehicle

application requirements. Refer to your machine technical manual for engine speeds that are different from those preset at the factory.

Power ratings specify flywheel power for a bare engine without the drag effect of a cooling fan or other accessories like an air compressor.

POWER RATINGS ON DYNAMOMETER FOR OEM ENGINES

Injection Pump Option Code	Original Injection Pump (Part No.)	Replaced By Injection Pump (Part No.)	Governor Regulation	Rated Speed (rpm) At Full Load	Slow Idle (rpm)	No Load Fast Idle (rpm)	Power Rating kW (HP)
1613	RE59861		STD	2500	850	2700	93 (125)
1614	RE61669	RE69789	STD	2500	850	2700	127 (170)
1614	RE69789		STD	2500	850	2700	127 (170)
1615	RE62366	RE69791	STD	2400	850	2600	138 (185)
1615	RE69791		STD	2400	850	2600	138 (185)
1619	RE67573		3—5%	1800	1150	1870	124 (166)
1621	RE66575	RE505930	STD	2400	850	2600	157 (210)
1621	RE505930		STD	2400	850	2600	157 (210)
1622	RE59521 ^a		STD	2400	850	2600	168 (225)
1623	RE66761 ^a		3—5%	1800	—	1870	148 (198)
1668	RE59969 ^a		STD	2400	850	2600	138 (185)
1678	RE60101		STD	2500	850	2700	93 (125)
1680	RE60105	RE69790	STD	2500	850	2700	127 (170)
1680	RE69790		STD	2500	850	2700	127 (170)
1681	RE60107	RE67571	3—5%	1800	1150	1870	112 (150)
1681	RE67571		3—5%	1800	1150	1870	112 (150)
1685	RE67574		3—5%	1800	1150	1870	124 (166)
1686	RE60131	RE69792	STD	2400	850	2600	138 (185)
1686	RE69792		STD	2400	850	2600	138 (185)
1688	RE67572		3—5%	1800	1150	1870	112 (150)
1696	RE67864	RE69787	STD	2500	850	2700	116 (155)
1696	RE69787		STD	2500	850	2700	116 (155)
1697	RE68740	RE69788	STD	2500	850	2700	116 (155)
1697	RE69788		STD	2500	850	2700	116 (155)
160D	RE69589	RE505962	STD	2400	850	2600	157 (210)
160D	RE505962		STD	2400	850	2600	157 (210)
163D	RE516159		STD	2200	850	2400	125 (168)
165H	RE503740		3—5%	1500	—	1560	105 (141)
165J	RE505052		3—5%	1500	—	1560	105 (141)
165K	RE503049		3—5%	1500	—	1560	120 (161)
165L	RE503834		3—5%	1500	—	1560	120 (161)
168Z	RE522415		3—5%	3000	850	3120	225 (302)
169A	RE522694		3—5%	3000	850	3120	225 (302)
169A	RE522809		3—5%	2200	850	2400	129 (173)
16AZ	RE522808		3—5%	2800	850	3000	226 (303)
16BE	RE63559	RE501302	STD	2200	950	2400	117 (157)
16BE	RE501302		STD	2200	950	2400	117 (157)
16CN	RE501522	RE509681	STD	2100	950	2300	110.5 (148)
16CN	RE509681		STD	2100	950	2300	110.5 (148)
16CP	RE501523		STD	2200	950	2400	94 (126)

Continued on next page

BL90236,0000002 -19-04SEP15-1/3

Specifications

POWER RATINGS ON DYNAMOMETER FOR OEM ENGINES

Injection Pump Option Code	Original Injection Pump (Part No.)	Replaced By Injection Pump (Part No.)	Governor Regulation	Rated Speed (rpm) At Full Load	Slow Idle (rpm)	No Load Fast Idle (rpm)	Power Rating kW (HP)
16CY	RE501345		STD	2200	1350	2400	143 (192)
16CW	RE501344		STD	2200	950	2400	106 (142)
16CX	RE70390		STD	2300	900	2500	128 (172)
16DK	RE70938		STD	2100	900	2300	96 (129)
16DY	RE501758		STD	2500	850	2700	116 (155)
16GM	RE502693		STD	2300	850	2500	110 (148)
16GN	RE502704		STD	2400	850	2600	116 (155)
16GS	RE503049		3—5%	1500	—	1560	121 (162)
16GT	RE503051		3—5%	1500	—	1560	155 (208)
16JU	RE69787		STD	2500	850	2700	116 (155)
16KK	RE502694		STD	2500	850	2700	127 (170)
16LR	RE59861		STD	2500	850	2700	93 (125)
16LS	RE67572		3—5%	1800	1150	1870	112 (150)
16LT	RE69791		STD	2400	850	2600	138 (185)
16LU	RE67573		3—5%	1800	1150	1870	124 (166)
16LX	RE503834		3—5%	1500	—	1560	121 (162)
16LX	RE503836		3—5%	1500	1400	1560	121 (162)
16LX	RE503834		3—5%	1500	—	1560	155 (208)
16LY	RE503834		3—5%	1500	1400	1560	155 (208)
16LY	RE503836		3—5%	1500	—	1560	153 (205)
16MG	RE503742		3—5%	1800	—	1870	123 (165)
16MH	RE504966	RE504967	3—5%	1800	—	1870	123 (165)
16MH	RE504967		3—5%	1800	—	1870	123 (165)
16MJ	RE503744		3—5%	1800	—	1870	142 (190)
16MK	RE504701	RE504968	3—5%	1800	—	1870	142 (190)
16MK	RE504968		3—5%	1800	—	1870	142 (190)
16ML	RE503746		3—5%	1800	1400	1870	187 (251)
16ML	RE503746		3—5%	1800	1400	1870	187 (251)
16MM	RE504702	RE505049	3—5%	1800	1400	1870	187 (251)
16MM	RE505049		3—5%	1800	1400	1870	187 (251)
16MX	RE503740		3—5%	1500	—	1560	105 (141)
16MY	RE504699	RE505052	3—5%	1500	—	1560	105 (141)
16MY	RE505052		3—5%	1500	—	1560	105 (141)
16NJ	RE505358		3—5%	1800	1150	1870	112 (150)
16PD	RE70938		STD	2100	850	2250	96 (129)
16QV	RE503051		3—5%	1800	1400	1870	166 (223)
16QW	RE503836		3—5%	1800	1400	1870	166 (223)
16RJ	RE506084		3—5%	2100	950	2200	172 (231)
16RK	RE506083		3—5%	2600	850	2700	138 (185)
16RL	RE506085		3—5%	2100	950	2200	197 (264)
16SG	RE506625		3—5%	2100	950	2200	172 (231)
16SH	RE506626		3—5%	2600	850	2700	138 (185)
16SJ	RE506627		3—5%	2100	950	2200	197 (264)
16TM	RE506885		3—5%	1800	—	1870	210 (282)
16TN	RE506886		3—5%	1800	—	1870	210 (282)
16TP	RE506883		3—5%	1500	1150	1560	183 (245)
16TQ	RE506884		3—5%	1500	1150	1560	183 (245)
16TV	RE506398		STD	2400	800	2550	168 (225)
16UG	RE506956	RE504321	STD	2400	925	2600	149(200)

Continued on next page

BL90236.0000002 -19-04SEP15-2/3

Specifications

POWER RATINGS ON DYNAMOMETER FOR OEM ENGINES

Injection Pump Option Code	Original Injection Pump (Part No.)	Replaced By Injection Pump (Part No.)	Governor Regulation	Rated Speed (rpm) At Full Load	Slow Idle (rpm)	No Load Fast Idle (rpm)	Power Rating kW (HP)
16UG	RE504321		STD	2400	925	2600	149 (200)
16YH	RE59969		STD	2400	850	2600	138 (185)
16ZH	RE62366		STD	2400	850	2600	138 (185)
16ZL	RE509424		3—5%	2100	950	2200	172 (231)
16ZM	RE509425		3—5%	2100	950	2200	172 (231)
16ZN	RE509426		STD	2600	850	2800	138 (185)
16ZP	RE509427		STD	2600	850	2800	138 (185)
16ZQ	RE509428		3—5%	2100	950	2200	197 (264)
16ZR	RE509429		3—5%	2100	950	2200	197 (264)

^aIn-line fuel injection pump.

BL90236,000002 -19-04SEP15-3/3

Engine Power Ratings And Fuel Injection Pump Specifications

NOTE: The power specifications shown below apply to Dubuque, Torreon and Saran-built OEM engines. Specifications are subject to change. Refer to factory DTAC for assistance.

Engine speeds listed are as preset to factory specification. In most cases, slow idle speed will be reset depending upon specific vehicle

application requirements. Refer to your machine technical manual for engine speeds that are different from those preset at the factory.

Power ratings specify flywheel power for a bare engine without the drag effect of a cooling fan or other accessories like an air compressor.

POWER RATINGS ON DYNAMOMETER FOR OEM ENGINES

Engine Model	Injection Pump Option Code	Original Injection Pump (Part No.)	Replaced By Injection Pump (Part No.)	Governor Regulation	Rated Speed (rpm) At Full Load	Slow Idle (rpm)	No Load Fast Idle (rpm)	Power Rating kW (HP)
4045DF120	16MR	RE504463		STD	2500	850	2700	63 (85)
	16MS	RE504464		STD	2500	850	2700	63 (85)
	165F	RE503729		3—5%	1500	—	1560	44 (59)
	165G	RE504693		3—5%	1500	—	1560	44 (59)
	16RB	RE503729		3—5%	1500	—	1560	44 (59)
	16RC	RE504693		3—5%	1500	—	1560	44 (59)
	16ZW	RE509527		3—5%	2500	850	2700	63 (85)
	16ZX	RE509528		3—5%	2500	850	2700	63 (85)
	16ZY	RE509529		3—5%	2500	850	2700	63 (85)
4045DF150	1601	RE61649	RE67557	STD	2500	850	2700	60 (80)
	1601	RE67557		STD	2500	850	2700	60 (80)
	1602	RE59809		STD	2500	850	2700	63 (85)
	1603	RE63555	RE67558	3—5%	1800	1150	1870	53 (71)
	1603	RE67558	RE505070	3—5%	1800	1150	1870	53 (71)
	1603	RE505070	RE506132	3—5%	1800	1150	1870	53 (71)
	1603	RE506132		3—5%	1800	1150	1870	53 (71)
	1663	RE71089	RE500949	STD	2500	1600	2700	60 (80)
	1663	RE500949		STD	2500	1600	2700	60 (80)
	1671	RE67559	RE502714	STD	2500	850	2700	60 (80)
	1671	RE502714		STD	2500	850	2700	60 (80)
	1673	RE60085	RE67560	3—5%	1800	1400	1870	53 (71)
	1673	RE67560	RE506130	3—5%	1800	1400	1870	53 (71)
	1673	RE506130		3—5%	1800	1400	1870	53 (71)
	1674	RE60089	RE67561	3—5%	1800	1400	1870	53 (71)
	1674	RE67561	RE506131	3—5%	1800	1400	1870	53 (71)
	1674	RE506131		3—5%	1800	1400	1870	53 (71)
	1691	RE61649	RE500831	STD	2500	850	2700	60 (80)
	1691	RE500831	RE500948	STD	2500	850	2700	60 (80)
	1691	RE500948		STD	2500	850	2700	60 (80)
	16BG	RE69778	RE502712	STD	2500	850	2700	63 (85)
	16BG	RE502712		STD	2500	850	2700	63 (85)
	16BH	RE500873	RE502715	STD	2500	850	2700	63 (85)
	16BH	RE502715		STD	2500	850	2700	63 (85)
	16BJ	RE500589		STD	2250	850	2450	36 (48)
	16CL	RE501364	RE502713	STD	2200	950	2400	58 (78)
	16CL	RE502713		STD	2200	950	2400	58 (78)
	16DL	RE70452		STD	2400	850	2600	61 (82)
	16EN	RE502019		STD	2500	850	2700	60 (80)
	16GB	RE502711		STD	2500	850	2700	60 (80)

Continued on next page

OURGP11.000001D -19-13OCT06-1/7

Specifications

POWER RATINGS ON DYNAMOMETER FOR OEM ENGINES

Engine Model	Injection Pump Option Code	Original Injection Pump (Part No.)	Replaced By Injection Pump (Part No.)	Governor Regulation	Rated Speed (rpm) At Full Load	Slow Idle (rpm)	No Load Fast Idle (rpm)	Power Rating kW (HP)
	16GC	RE502716		STD	2500	850	2700	60 (80)
	16HJ	RE500948		STD	2500	1400	2700	60 (80)
	16HK	RE500949		STD	2500	1600	2700	60 (80)
	16HV	RE503258		STD	2250	850	2450	36 (48)
	16KE	RE503560		STD	2500	850	2700	52 (70)
	16LM	RE502711		STD	2500	850	2700	53 (71)
	16LN	RE67558	RE505070	3—5%	1800	1150	1870	53 (71)
	16LN	RE505070	RE506132	3—5%	1800	1150	1870	53 (71)
	16LN	RE506132		3—5%	1800	1150	1870	53 (71)
	16RB	RE503729		3—5%	1500	1400	1560	44 (59)
	16RC	RE504693		3—5%	1500	1400	1560	44 (59)
	165W	RE500949		STD	2500	1600	2700	60 (80)
4045DF151	1663	RE71089	RE500949	STD	2500	1600	2700	60 (80)
	1663	RE500949		STD	2500	1600	2700	60 (80)
4045DF152	1601	RE67557		STD	2500	850	2700	60 (80)
	16GB	RE502711		STD	2500	850	2700	60 (80)
4045DF154	16AY	RE500505		STD	2400	850	2600	62 (83)
	16JS	RE500505		STD	2400	850	2600	62 (83)
4045HF120	16GR	RE503050	RE506965	3—5%	1500	1400	1560	102 (137)
	16LW	RE503832	RE506966	3—5%	1500	1400	1560	102 (137)
4045HF150	1610	RE68826	RE505928	STD	2400	850	2600	104 (140)
	1611	RE60237		3—5%	1800	1400	1870	95 (127)
	160B	RE68827		3—5%	1800	1400	1870	95 (127)
	160C	RE69588	RE505959	STD	2400	850	2600	104 (140)
	16GR	RE503050		3—5%	1500	1150	1560	100 (134)
	16LW	RE503832		3—5%	1500	1150	1560	100 (134)
	16ME	RE503739		3—5%	1800	—	1870	120 (161)
	16MF	RE504966		3—5%	1800	—	1870	123 (164)
	16QZ	RE503050		3—5%	1800	1400	1870	111 (149)
	16RA	RE503832		3—5%	1800	1400	1870	111 (149)
4045HF152	16RM	RE505959		STD	2400	850	2600	104 (140)
4045HF157	16GR	RE503050			1500	—	1560	102 (137)
	16LW	RE503832			1500	—	1560	102 (137)
4045HF158	16GR	RE503050		3—5%	1500	1150	1560	100 (134)
	16LW	RE503832		3—5%	1500	1150	1560	100 (134)
	16ME	RE503739		3—5%	1800	1400	1870	123 (165)
	16MF	RE504698	RE504966	3—5%	1800	1400	1870	123 (170)
	16MF	RE504966		3—5%	1800	1400	1870	123 (170)
4045HF252		RE522414		3—5%	3000	850	3120	125 (168)
		RE522698		3—5%	3000	850	3120	125 (168)
	169E	RE522414		3—5%	3000	850	3120	152 (204)
	169F	RE522698		3—5%	3000	850	3120	152 (204)
4045TF120	16MT	RE503733	RE505989	3—5%	1500	1400	1560	70 (94)
	16MT	RE506989		3—5%	1500	1400	1560	70 (94)
	16MU	RE505050	RE506990	3—5%	1500	1400	1560	70 (94)
	16MU	RE506990		3—5%	1500	1400	1560	70 (94)
	16ZW	RE509527		3—5%	1500	1400	1560	70 (94)
	16ZX	RE509528		3—5%	1500	1400	1560	70 (94)
	16ZY	RE509529		3—5%	1500	1400	1560	70 (94)

Continued on next page

OURGP11.000001D -19-13OCT06-2/7

Specifications

POWER RATINGS ON DYNAMOMETER FOR OEM ENGINES

Engine Model	Injection Pump Option Code	Original Injection Pump (Part No.)	Replaced By Injection Pump (Part No.)	Governor Regulation	Rated Speed (rpm) At Full Load	Slow Idle (rpm)	No Load Fast Idle (rpm)	Power Rating kW (HP)
	165D	RE506989		3—5%	1500	—	1560	70 (94)
	165E	RE506990		3—5%	1500	—	1560	70 (94)
4045TF150	1605	RE61668	RE69781	STD	2500	850	2700	86 (115)
	1605	RE69781		STD	2500	850	2700	86 (115)
	1606	RE64133	RE505927	STD	2400	850	2600	93 (125)
	1606	RE505927		STD	2400	850	2600	93 (125)
	1656	RE63610	RE67562	3—5%	1800	1150	1870	75 (100)
	1656	RE67562		3—5%	1800	1150	1870	75 (100)
	1675	RE60091	RE69782	STD	2500	850	2700	86 (115)
	1675	RE69782		STD	2500	850	2700	86 (115)
	1676	RE60093	RE61668	STD	2500	850	2700	86 (115)
	1676		RE61668	STD	2500	850	2700	86 (115)
	1677	RE60096	RE67563	3—5%	1800	1150	1870	75 (100)
	1677	RE67563		3—5%	1800	1150	1870	75 (100)
	1692	RE61668	RE500881	STD	2500	1400	2700	86 (115)
	1692	RE500881	RE502416	STD	2500	1400	2700	86 (115)
	1692	RE502416		STD	2500	1400	2700	86 (115)
	1694	RE67863	RE69779	STD	2500	850	2700	75 (100)
	1694	RE69779		STD	2500	850	2700	75 (100)
	1695	RE69739	RE69780	STD	2500	850	2700	75 (100)
	1695	RE69780		STD	2500	850	2700	75 (100)
	16AB	RE69779		STD	2500	850	2700	75 (100)
	16BF	RE500848		STD	2200	950	2400	73 (98)
	16CE	RE501180		STD	2500	850	2700	75 (100)
	16CM	RE501365		STD	2200	950	2400	66.6 (89)
	16GL	RE502706		STD	2300	850	2500	78 (105)
	16LP	RE67562		3—5%	1800	1150	1870	75 (100)
	16LZ	RE503735		3—5%	1800	1400	1870	70 (94)
	16MA	RE504696	RE504931	3—5%	1800	1400	1870	82 (110)
	16MA	RE504931		3—5%	1800	1400	1870	82 (110)
	16MT	RE503733	RE505050	3—5%	1500	1400	1560	70 (94)
	16MT	RE505050		3—5%	1500	1400	1560	70 (94)
	16MU	RE504695	RE505050	3—5%	1500	1400	1560	70 (94)
	16MU	RE505050	RE506990	3—5%	1500	1400	1560	70 (94)
	16MU	RE506990		3—5%	1500	1400	1560	70 (94)
	16TG	RE507941		STD	2000	850	2185	77 (103)
	16YJ	RE508834		STD	2000	850	2185	77 (103)
	16YU	RE508754		3—5%	1800	—	1870	75 (101)
	16ZC	RE518780		STD	2200	950	2400	66 (89)
4045TF151	1677	RE60096	RE67563	3—5%	1800	850	1870	75 (100)
	1677	RE67563		3—5%	1800	850	1870	75 (100)
	16CU	RE501192		STD	2200	850	2400	79.5 (107)
	16NH	RE505411		3—5%	1800	1150	2240	75 (100)
4045TF152	16AX	RE500551		STD	2400	850	2600	76 (102)
4045TF154	1605	RE69781		STD	2500	850	2700	86 (115)
4045TF155	16AX	RE500551		STD	2400	850	2600	76 (102)
	16JT	RE500551		STD	2400	850	2600	76 (102)
4045TF157	16GQ	RE503048		3—5%	1500	—	1560	83 (111)
	16LV	RE503830		3—5%	1500	—	1560	83 (111)

Continued on next page

OURGP11,00001D -19-13OCT06-3/7

Specifications

POWER RATINGS ON DYNAMOMETER FOR OEM ENGINES

Engine Model	Injection Pump Option Code	Original Injection Pump (Part No.)	Replaced By Injection Pump (Part No.)	Governor Regulation	Rated Speed (rpm) At Full Load	Slow Idle (rpm)	No Load Fast Idle (rpm)	Power Rating kW (HP)
4045TF158	16GQ	RE503048		3—5%	1500	—	1560	83 (111)
	16LZ	RE503735		3—5%	1800	—	1870	82 (110)
	16MA	RE504696		3—5%	1800	—	1870	82 (110)
	16MT	RE503733	RE506989	3—5%	1500	—	1560	70 (94)
	16MT	RE506989		3—5%	1500	—	1560	70 (94)
	16MU	RE504695	RE505050	3—5%	1500	—	1560	70 (94)
	16MU	RE505050	RE506990	3—5%	1500	—	1560	70 (94)
	16MU	RE506990		3—5%	1500	—	1560	70 (94)
4045TF161	16PZ	RE500848		STD	2200	850	2400	73 (98)
4045TF162	16GL	RE502706		STD	2300	850	2500	78 (104)
4045TF220	16GQ	RE503048	RE506544	3—5%	1500	1400	1560	83 (111)
	16GQ	RE506544		3—5%	1500	1400	1560	83 (111)
	16LV	RE503830	RE506545	3—5%	1500	1400	1560	83 (111)
	16LV	RE506545		3—5%	1500	1400	1560	83 (111)
	16MT	RE503733		3—5%	1500	1400	1560	70 (94)
	16MV	RE503736		3—5%	1800	1400	1870	100 (134)
	16MW	RE504682		3—5%	1800	1400	1870	100 (134)
	16NT	RE504465		STD	2500	850	2700	86 (115)
	16NU	RE504466		STD	2500	850	2700	86 (115)
	16ZZ	RE508613		STD	2100	850	2200	107 (143)
	161A	RE509525		STD	2100	850	2200	107 (143)
	161B	RE509526		STD	2100	850	2200	107 (143)
	168Q	RE521143		3—5%	1500	—	1560	83 (111)
	168R	RE522388		3—5%	1500	—	1560	83 (111)
4045TF250	1606	RE64133	RE505927	STD	2400	850	2600	93 (125)
	1606	RE505927		STD	2400	850	2600	93 (125)
	1608	RE67564		3—5%	1800	1400	1870	84 (113)
	1667	RE59968		STD	2400	850	2600	93 (125)
	1682	RE67566		3—5%	1800	1400	1870	84 (113)
	1683	RE60124	RE505926	STD	2400	850	2600	93 (125)
	1683	RE505926		STD	2400	850	2600	93 (125)
	160R	RE70941		3—5%	1800	1400	1870	84 (113)
	16CV	RE501346		STD	2200	950	2400	85 (114)
	16GQ	RE503048		3—5%	1500	1150	1560	83 (111)
	16LQ	RE67564		3—5%	1800	1400	1870	84 (113)
	16LV	RE503830		3—5%	1500	1150	1560	83 (111)
	16MB	RE503737		3—5%	1800	1400	1870	91(122)
	16MC	RE504932		3—5%	1800	1400	1870	91 (122)
	161C	RE507525	RE506881	3—5%	1800	1400	1870	100 (134)
	161D	RE507526	RE506882	3—5%	1800	1400	1870	100 (134)
	163Z	RE505927		STD	2400	850	2600	93 (125)
4045TF251	1606	RE64133	RE505927	STD	2400	850	2600	93 (125)
	1606	RE505927		STD	2400	850	2600	93 (125)
4045TF252	169P	RE522714		3—5%	3000	850	3120	119 (160)
	169Q	RE522697		3—5%	3000	850	3120	119 (160)
4045TF253	16TE	RE507257		STD	2400	850	2600	85 (114)
4045TF257	16GQ	RE503048		3—5%	1500	—	1560	83 (111)
	16LV	RE503830		3—5%	1500	—	1560	83 (111)
4045TF258	16GQ	RE503048		3—5%	1500	—	1560	83 (111)

Continued on next page

OURGP11.000001D -19-13OCT06-4/7

Specifications

POWER RATINGS ON DYNAMOMETER FOR OEM ENGINES

Engine Model	Injection Pump Option Code	Original Injection Pump (Part No.)	Replaced By Injection Pump (Part No.)	Governor Regulation	Rated Speed (rpm) At Full Load	Slow Idle (rpm)	No Load Fast Idle (rpm)	Power Rating kW (HP)
	16LV	RE503830		3—5%	1500	—	1560	83 (111)
	16MB	RE503737		3—5%	1800	1400	1870	91 (122)
	16MC	RE504932		3—5%	1800	1400	1870	91 (122)
	16MV	RE503736		3—5%	1800	1400	1870	100 (134)
	16MW	RE504682		3—5%	1800	1400	1870	100 (134)
6068DF150	1613	RE59861		STD	2500	850	2700	93 (125)
	1678	RE60101		STD	2500	850	2700	93 (125)
	16LR	RE59861		STD	2500	850	2700	93 (125)
6068HF120	16GT	RE503051		3—5%	1500	1400	1560	155 (208)
	16LY	RE503834		3—5%	1500	1400	1560	155 (208)
	16RL	RE506085		3—5%	2100	950	2200	197 (264)
	16SJ	RE506627		3—5%	2100	950	2200	197 (264)
	16TP	RE506883		3—5%	1500	1150	1560	183 (245)
	16TQ	RE506884		3—5%	1500	1150	1560	183 (245)
	16ZQ	RE509428		3—5%	2100	950	2200	197 (264)
	16ZR	RE509429		3—5%	2100	950	2200	197 (264)
6068HF150	1621	RE66575	RE505930	STD	2400	850	2600	157 (210)
	1621	RE505930		STD	2400	850	2600	157 (210)
	160D	RE69589	RE505962	STD	2400	850	2600	157 (210)
	160D	RE505962		STD	2400	850	2600	157 (210)
	16CY	RE501345		STD	2200	1350	2400	143 (192)
	16GT	RE503051		3—5%	1500	1400	1560	153 (205)
	16LY	RE503836		3—5%	1500	1400	1560	153 (205)
	16ML	RE503746		3—5%	1800	1400	1870	187 (251)
	16MM	RE504702	RE505049	3—5%	1800	1400	1870	187 (251)
	16MM	RE505049		3—5%	1800	1400	1870	187 (251)
	16QV	RE503051		3—5%	1800	1400	1870	166 (223)
	16QW	RE503836		3—5%	1800	1400	1870	166 (223)
	16TM	RE506885		3—5%	1800	—	1870	210 (282)
	16TN	RE506886		3—5%	1800	—	1870	210 (282)
6068HF157	16GT	RE503051		3—5%	1500	—	1560	155 (208)
	16LY	RE503836		3—5%	1500	—	1560	155 (208)
6068HF158	16GT	RE503051		3—5%	1500	—	1560	155 (208)
	16LY	RE503836		3—5%	1500	—	1560	155 (208)
	16ML	RE503746		3—5%	1800	1400	1870	187 (251)
	16MM	RE504702	RE505049	3—5%	1800	1400	1870	187 (251)
	16MM	RE505049		3—5%	1800	1400	1870	187 (251)
6068HF250	1622	RE59521 ^a		STD	2400	850	2600	168 (225)
	1623	RE66761 ^a		3—5%	1800	—	1870	148 (198)
	16TV	RE506398		STD	2400	800	2550	168 (225)
	16YH	RE59969		STD	2400	850	2600	138 (185)
6068HF252	169A	RE522694		3—5%	3000	850	3120	225 (302)
	168Z	RE522415		3—5%	3000	850	3120	225 (302)
6068HF254				3—5%	2800	850	3000	226 (303)
				3—5%	2800	850	3000	184 (247)
6068HF258	16TM (12V)	RE506885		3—5%	1800	—	1870	210 (282)
	16TN (24V)	RE506886		3—5%	1800	—	1870	210 (282)
	16TP (12V)	RE506883		3—5%	1500	—	1560	183 (245)
	16TQ (24V)	RE506884		3—5%	1500	—	1560	183 (245)

Continued on next page

OURGP11,000001D -19-13OCT06-5/7

Specifications

POWER RATINGS ON DYNAMOMETER FOR OEM ENGINES

Engine Model	Injection Pump Option Code	Original Injection Pump (Part No.)	Replaced By Injection Pump (Part No.)	Governor Regulation	Rated Speed (rpm) At Full Load	Slow Idle (rpm)	No Load Fast Idle (rpm)	Power Rating kW (HP)
6068TF120	16MX	RE503740		3—5%	1500	1400	1560	105 (141)
	16MY	RE505052		3—5%	1500	1400	1560	105 (141)
6068TF150	1614	RE61669	RE69789	STD	2500	850	2700	127 (170)
	1614	RE69789		STD	2500	850	2700	127 (170)
	1680	RE60105	RE69790	STD	2500	850	2700	127 (170)
	1680	RE69790		STD	2500	850	2700	127 (170)
	1681	RE60107	RE67571	3—5%	1800	1150	1870	112 (150)
	1681	RE67571		3—5%	1800	1150	1870	112 (150)
	1688	RE67572		3—5%	1800	1150	1870	112 (150)
	1696	RE67864	RE69787	STD	2500	850	2700	116 (155)
	1696	RE69787		STD	2500	850	2700	116 (155)
	1697	RE68740	RE69788	STD	2500	850	2700	116 (155)
	1697	RE69788		STD	2500	850	2700	116 (155)
	16BE	RE63559	RE501302	STD	2200	950	2400	117 (157)
	16BE	RE501302		STD	2200	950	2400	117 (157)
	16CN	RE501522	RE509681	STD	2100	950	2300	110.5 (148)
16CN	RE509681		STD	2100	950	2300	110.5 (148)	
16CP	RE501523		STD	2200	950	2400	94 (126)	
16DK	RE70938		STD	2100	900	2300	96 (129)	
16DY	RE501758		STD	2500	850	2700	116 (155)	
16GM	RE502693		STD	2300	850	2500	110 (148)	
16GN	RE502704		STD	2400	850	2600	116 (155)	
16LS	RE67572		3—5%	1800	1150	1870	112 (150)	
16MG	RE503742		3—5%	1800	1400	1870	123 (165)	
16MH	RE504967		3—5%	1800	1400	1870	123 (165)	
6068TF151	1681	RE60107	RE67651	3—5%	1800	1150	1870	112 (150)
	1681	RE67651		3—5%	1800	1150	1870	112 (150)
	16NJ	RE505358		3—5%	1800	1150	1870	112 (150)
	1696	RE69787		STD	2500	850	2700	116 (155)
6068TF152	1696	RE69787		STD	2500	850	2700	116 (155)
	16JU	RE69787		STD	2500	850	2700	116 (155)
6068TF157	16GS	RE503049		3—5%	1500	—	1560	121 (162)
	16LX	RE503834		3—5%	1500	—	1560	121 (162)
6068TF158	16GS	RE503049		3—5%	1500	—	1560	121 (162)
	165H	RE503740		3—5%	1500	—	1560	105 (141)
	165J	RE505052		3—5%	1500	—	1560	105 (141)
	16MG	RE503742		3—5%	1800	—	1870	123 (165)
	16MH	RE504966	RE504967	3—5%	1800	—	1870	123 (165)
	16MH	RE504967		3—5%	1800	—	1870	123 (165)
	16MX	RE503740		3—5%	1500	—	1560	105 (141)
	16MY	RE504699	RE505052	3—5%	1500	—	1560	105 (141)
	16MY	RE505052		3—5%	1500	—	1560	105 (141)
6068TF159	16PD	RE70938		STD	2100	850	2250	96 (129)
6068TF220	16GS	RE503049		3—5%	1500	1400	1560	121 (162)
	16KK	RE502694		STD	2500	850	2700	127 (170)
	16LX	RE503836		3—5%	1500	1400	1560	121 (162)
	16RK	RE506083		3—5%	2600	850	2700	138 (185)
	16RJ	RE506084		3—5%	2100	950	2200	172 (231)
	16SG	RE506625		3—5%	2100	950	2200	172 (231)

Continued on next page

OURGP11.000001D -19-13OCT06-6/7

Specifications

POWER RATINGS ON DYNAMOMETER FOR OEM ENGINES

Engine Model	Injection Pump Option Code	Original Injection Pump (Part No.)	Replaced By Injection Pump (Part No.)	Governor Regulation	Rated Speed (rpm) At Full Load	Slow Idle (rpm)	No Load Fast Idle (rpm)	Power Rating kW (HP)
	16SH	RE506626		3—5%	2600	850	2700	138 (185)
	16ZL	RE509424		3—5%	2100	950	2200	172 (231)
	16ZM	RE509425		3—5%	2100	950	2200	172 (231)
	16ZN	RE509426		STD	2600	850	2800	138 (185)
	16ZP	RE509427		STD	2600	850	2800	138 (185)
	165K	RE503049		3—5%	1500	—	1560	120 (161)
	165L	RE503834		3—5%	1500	—	1560	120 (161)
6068TF250	1615	RE62366	RE69791	STD	2400	850	2600	138 (185)
	1615	RE69791		STD	2400	850	2600	138 (185)
	1619	RE67573		3—5%	1800	1150	1870	124 (166)
	1668	RE59969 ^a		STD	2400	850	2600	138 (185)
	1685	RE67574		3—5%	1800	1150	1870	124 (166)
	1686	RE60131	RE69792	STD	2400	850	2600	138 (185)
	1686	RE69792		STD	2400	850	2600	138 (185)
	16CW	RE501344		STD	2200	950	2400	106 (142)
	16CX	RE70390		STD	2300	900	2500	128 (172)
	16GS	RE503049		3—5%	1500	1400	1560	120 (161)
	16LT	RE69791		STD	2400	850	2600	138 (185)
	16LU	RE67573		3—5%	1800	1150	1870	124 (166)
	16LX	RE503834		3—5%	1500	1400	1560	120 (161)
	16MJ	RE503744		3—5%	1800	1400	1870	142 (190)
	16MK	RE504701	RE504968	3—5%	1800	1400	1870	142 (190)
	16MK	RE504968		3—5%	1800	1400	1870	142 (190)
	163D	RE516159		STD	2200	850	2400	125 (168)
	16UG	RE506956	RE504321	STD	2400	925	2600	149(200)
	16UG	RE504321		STD	2400	925	2600	149 (200)
	16YH	RE59969		STD	2400	850	2600	138 (185)
6068TF251	1615	RE62366		STD	2400	850	2600	138 (185)
	16ZH	RE62366		STD	2400	850	2600	138 (185)
6068TF257	16GS	RE503049		3—5%	1500	—	1560	121 (162)
	16LX	RE503834		3—5%	1500	—	1560	155 (208)
6068TF258	16GS	RE503049		3—5%	1500	—	1560	121 (162)
	16LX	RE503834		3—5%	1500	—	1560	155 (208)
	16MJ	RE503744		3—5%	1800	—	1870	142 (190)
	16MK	RE504701	RE504968	3—5%	1800	—	1870	142 (190)
	16MK	RE504968		3—5%	1800	—	1870	142 (190)

^aIn-line fuel injection pump.

OURGP11,00001D -19-13OCT06-7/7

Specifications

Engine Crankcase Oil Fill Quantities

NOTE: Crankcase oil capacity may vary slightly from amount shown. ALWAYS fill crankcase to within crosshatch on dipstick. DO NOT overfill.

To determine the option code for the oil fill quantity of your engine, refer to the engine option code label affixed to

the rocker arm cover. The first two digits of the code (19) identify the oil pan option group. The last two digits of each code identify the specific oil pan on your engine.

The following table lists engine crankcase oil fill quantities for each "19__" option code for these engines.

Engine Model	Oil Pan Option Code(s)	Crankcase Oil Capacity L (qt)
4045	1901	7.5 (8.0)
	1902	8.0 (8.5)
	1903	12.0 (12.7)
	1904	13.5 (14.3)
	1921	16.5 (17.4)
	1922	16.5 (17.4)
	1923	15.0 (15.8)
	1934	12.5 (13.2)
	1936	12.5 (13.2)
	1937	12.5 (13.2)
	1949	12.0 (12.7)
	1962	14.0 (14.8)
	19AE	15.2 (16.1)
6068	1907	19.5 (20.6)
	1908	19.0 (20.1)
	1909	19.0 (20.1)
	1924	24.2 (25.6)
	1944	20.0 (21.1)
	1948	20.0 (21.1)
	1950	20.0 (21.1)
	1956	19.0 (20.1)
	1961	33.0 (34.9)
	1963	21.5 (22.7)
	1968	32.0 (33.8)
19AC	28.0 (29.6)	

OURGP11,000001E -19-20AUG15-1/1

Unified Inch Bolt and Screw Torque Values

TS1671 —UN—01MAY03

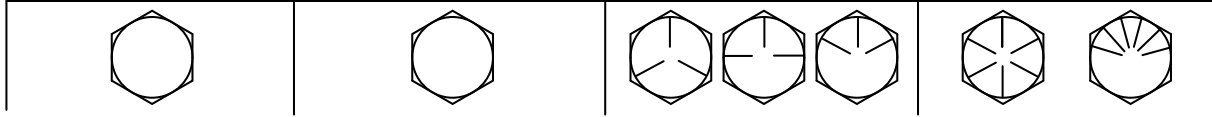

Bolt or Screw Size	SAE Grade 1 ^a				SAE Grade 2 ^b				SAE Grade 5, 5.1 or 5.2				SAE Grade 8 or 8.2			
	Hex Head ^c		Flange Head ^d		Hex Head ^c		Flange Head ^d		Hex Head ^c		Flange Head ^d		Hex Head ^c		Flange Head ^d	
	N·m	lb·in	N·m	lb·in	N·m	lb·in	N·m	lb·in	N·m	lb·in	N·m	lb·in	N·m	lb·in	N·m	lb·in
1/4	3.1	27.3	3.2	28.4	5.1	45.5	5.3	47.3	7.9	70.2	8.3	73.1	11.2	99.2	11.6	103
5/16	6.1	54.1	6.5	57.7	10.2	90.2	10.9	96.2	15.7	139	16.8	149	22.2	16.4	23.7	17.5
3/8	10.5	93.6	11.5	102	17.6	156	19.2	170	27.3	20.1	29.7	21.9	38.5	28.4	41.9	30.9
7/16	16.7	148	18.4	163	27.8	20.5	30.6	22.6	43	31.7	47.3	34.9	60.6	44.7	66.8	49.3
1/2	25.9	19.1	28.2	20.8	43.1	31.8	47	34.7	66.6	49.1	72.8	53.7	94	69.3	103	75.8
9/16	36.7	27.1	40.5	29.9	61.1	45.1	67.5	49.8	94.6	69.8	104	77	134	98.5	148	109
5/8	51	37.6	55.9	41.2	85	62.7	93.1	68.7	131	96.9	144	106	186	137	203	150
3/4	89.5	66	98	72.3	149	110	164	121	230	170	252	186	325	240	357	263
7/8	144	106	157	116	144	106	157	116	370	273	405	299	522	385	572	422
1	216	159	236	174	216	159	236	174	556	410	609	449	785	579	860	634
1-1/8	305	225	335	247	305	225	335	247	685	505	751	554	1110	819	1218	898
1-1/4	427	315	469	346	427	315	469	346	957	706	1051	775	1552	1145	1703	1256
1-3/8	564	416	618	456	564	416	618	456	1264	932	1386	1022	2050	1512	2248	1658
1-1/2	743	548	815	601	743	548	815	601	1665	1228	1826	1347	2699	1991	2962	2185

The nominal torque values listed are for general use only with the assumed wrenching accuracy of 20%, such as a manual torque wrench. DO NOT use these values if a different torque value or tightening procedure is given for a specific application. For lock nuts, for stainless steel fasteners, or for nuts on U-bolts, see the tightening instructions for the specific application.

Replace fasteners with the same or higher property class. If higher property class fasteners are used, tighten these to the strength of the original.

- Make sure that fastener threads are clean.
- Apply a thin coat of Hy-Gard™ or equivalent oil under the head and on the threads of the fastener, as shown in the following image.
- Be conservative with the amount of oil to reduce the potential for hydraulic lockup in blind holes due to excessive oil.
- Properly start thread engagement.

TS1741 —UN—22MAY18

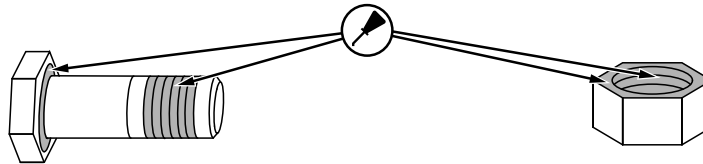

^aGrade 1 applies for hex cap screws over 6 in (152 mm) long, and for all other types of bolts and screws of any length.

^bGrade 2 applies for hex cap screws (not hex bolts) up to 6 in (152 mm) long.

^cHex head column values are valid for ISO 4014 and ISO 4017 hex head, ISO 4162 hex socket head, and ISO 4032 hex nuts.

^dHex flange column values are valid for ASME B18.2.3.9M, ISO 4161, or EN 1665 hex flange products.

Specifications

Metric Bolt and Screw Torque Values

TS1742 —UN—31MAY18

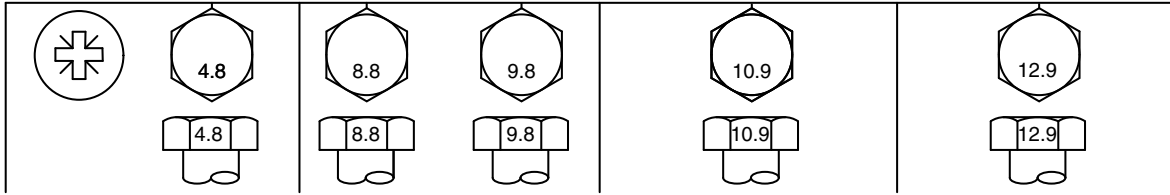

Bolt or Screw Size	Class 4.8				Class 8.8 or 9.8				Class 10.9				Class 12.9			
	Hex Head ^a		Flange Head ^b		Hex Head ^a		Flange Head ^b		Hex Head ^a		Flange Head ^b		Hex Head ^a		Flange Head ^b	
	N·m	lb·in	N·m	lb·in	N·m	lb·in	N·m	lb·in	N·m	lb·in	N·m	lb·in	N·m	lb·in	N·m	lb·in
M6	3.6	31.9	3.9	34.5	6.7	59.3	7.3	64.6	9.8	86.7	10.8	95.6	11.5	102	12.6	112
									N·m	lb·ft	N·m	lb·ft	N·m	lb·ft	N·m	lb·ft
M8	8.6	76.1	9.4	83.2	16.2	143	17.6	156	23.8	17.6	25.9	19.1	27.8	20.5	30.3	22.3
			N·m	lb·ft	N·m	lb·ft	N·m	lb·ft								
M10	16.9	150	18.4	13.6	31.9	23.5	34.7	25.6	46.8	34.5	51	37.6	55	40.6	60	44.3
	N·m	lb·ft														
M12	—	—	—	—	55	40.6	61	45	81	59.7	89	65.6	95	70.1	105	77.4
M14	—	—	—	—	87	64.2	96	70.8	128	94.4	141	104	150	111	165	122
M16	—	—	—	—	135	99.6	149	110	198	146	219	162	232	171	257	190
M18	—	—	—	—	193	142	214	158	275	203	304	224	322	245	356	263
M20	—	—	—	—	272	201	301	222	387	285	428	316	453	334	501	370
M22	—	—	—	—	365	263	405	299	520	384	576	425	608	448	674	497
M24	—	—	—	—	468	345	518	382	666	491	738	544	780	575	864	637
M27	—	—	—	—	683	504	758	559	973	718	1080	797	1139	840	1263	932
M30	—	—	—	—	932	687	1029	759	1327	979	1466	1081	1553	1145	1715	1265
M33	—	—	—	—	1258	928	1398	1031	1788	1319	1986	1465	2092	1543	2324	1714
M36	—	—	—	—	1617	1193	1789	1319	2303	1699	2548	1879	2695	1988	2982	2199

The nominal torque values listed are for general use only with the assumed wrenching accuracy of 20%, such as a manual torque wrench. DO NOT use these values if a different torque value or tightening procedure is given for a specific application. For lock nuts, for stainless steel fasteners, or for nuts on U-bolts, see the tightening instructions for the specific application.

Replace fasteners with the same or higher property class. If higher property class fasteners are used, tighten these to the strength of the original.

- Make sure that fastener threads are clean.
- Apply a thin coat of Hy-Gard™ or equivalent oil under the head and on the threads of the fastener, as shown in the following image.
- Be conservative with the amount of oil to reduce the potential for hydraulic lockup in blind holes due to excessive oil.
- Properly start thread engagement.

TS1741 —UN—22MAY18

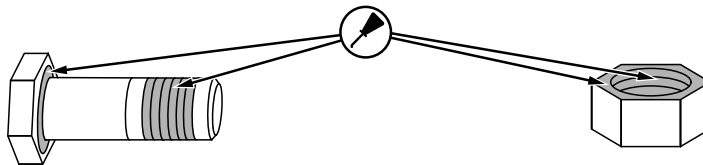

^aHex head column values are valid for ISO 4014 and ISO 4017 hex head, ISO 4162 hex socket head, and ISO 4032 hex nuts.

^bHex flange column values are valid for ASME B18.2.3.9M, ISO 4161, or EN 1665 hex flange products.

DX,TORQ2 -19-30MAY18-1/1

Lubrication and Maintenance Records

Using Lubrication and Maintenance Records

Refer to specific Lubrication and Maintenance Section for detailed service procedures.

1. Keep a record of the number of hours you operate your engine by regular observation of hour meter.
2. Check your record regularly to learn when your engine needs service.
3. DO ALL the services within an interval section. Write the number of hours (from your service records) and

the date in the spaces provided. For a complete listing of all items to be performed and the service intervals required, refer to the quick-reference chart near the front of the Lubrication and Maintenance Section.

IMPORTANT: The service recommendations covered in this manual are for the accessories that are provided by John Deere. Follow manufacturer's service recommendations for servicing engine driven equipment not supplied by Deere.

RG, RG34710, 5620 -19-24AUG10-1/1

Daily (Prestarting) Service

- Check engine oil level.
- Check coolant level.

IMPORTANT: Drain water by rotating drain valve on fuel/water separator bowl counterclockwise. Premature injection pump failure may occur if water is not drained daily.

- Check fuel filter/water separator bowl.
- Check air cleaner dust unloader valve and air restriction indicator, if equipped.
- Visual walkaround inspection.

RG, RG34710, 5621 -19-07JAN02-1/1

250 Hour/6 Month Service

- Change engine oil and filter.¹
- Service fire extinguisher.
- Check engine mounts.
- Service battery.
- Check automatic belt tensioner and belt wear.

Hours									
Date									
Hours									
Date									
Hours									
Date									
Hours									
Date									
Hours									
Date									
Hours									
Date									
Hours									
Date									
Hours									
Date									

¹If John Deere PLUS-50 or ACEA-E4/E5 oil is used along with a John Deere oil filter, the oil and filter change interval may be extended by 50 percent.

OURGP12, 0000043 -19-31OCT06-1/1

500 Hour/12 Month Service

- Clean crankcase vent tube.
- Check air intake hoses, connections, and system.
- Replace single or dual fuel filter elements.
- Check automatic belt tensioner and belt wear.
- Check engine speeds.
- Check engine electrical ground connection.
- Check cooling system.
- Coolant solution analysis – add SCAs as needed.
- Pressure test cooling system.

Hours									
Date									
Hours									
Date									
Hours									
Date									
Hours									
Date									
Hours									
Date									
Hours									
Date									
Hours									
Date									
Hours									
Date									
Hours									
Date									

OURGP12,0000044 -19-07JUL04-1/1

2000 Hour/24 Month Service

- Check crankshaft vibration damper (6-cylinder only).
- Flush cooling system.¹
- Test thermostats.
- Check and adjust valve clearance.

Hours									
Date									
Hours									
Date									
Hours									
Date									
Hours									
Date									
Hours									
Date									
Hours									
Date									
Hours									
Date									
Hours									
Date									

¹If John Deere COOL-GARD is used, the flushing interval may be extended to 3000 hours, or 36 months. If John Deere COOL-GARD is used and the coolant is tested annually AND additives are replenished as needed by adding a supplemental coolant additive, the flushing interval may be extended to 5000 hours or 60 months, whichever occurs first.

RG, RG34710, 5625 -19-20MAY96-1/1

Lubrication and Maintenance Records

Service as Required

- Add coolant
- Service air cleaner.
- Replace poly-vee belts.
- Check fuses
- Check air compressor (if equipped).
- Bleed fuel system

Hours									
Date									
Hours									
Date									
Hours									
Date									
Hours									
Date									
Hours									
Date									
Hours									
Date									
Hours									
Date									
Hours									
Date									

OURGP12.0000045 -19-07.JUL04-1/1

Warranty

John Deere Warranty in OEM Applications

Overview

This section focuses on John Deere engines marketed in products manufactured by companies other than John Deere or its affiliates, and on John Deere repower engines in all applications. Herein appears the original warranty applicable to the engine as delivered to the retail purchaser on or after 1 May 2010. The following is information about the warranty and warranty service.

NOTE: "John Deere" means John Deere Power Systems with respect to users in the United States, John Deere Limited with respect to users in Canada, and Deere & Company or its subsidiary responsible for making John Deere equipment in other countries where the user is located.

Promptly register your engine online at <https://www.johndeere.com/enginewarranty>

When Warranty Service Is Needed

The nearest dealer stands ready with genuine parts and trained and equipped personnel should the need arise. If following the Operator's Manual delivered with the engine/machine are not adequate to correct an engine problem, contact the nearest John Deere service dealer for assistance. Authorized engine service dealers can be found at: <https://www.johndeere.com/> (click on "Dealer Locator").

NOTE: When requesting warranty service, the purchaser must be prepared to provide proof that the engine is within the warranty period.

The following information is always required: Engine serial number, date of delivery, engine owner, name and location of dealer and specific person contacted, date of contact, nature of engine problem, and outcome of the service dealer contact.

Given that normally it is the dealer contacted who in the end will provide the service required, maintaining a purchaser-dealer relationship of mutual respect from the beginning is always helpful.

Privacy Notice

At John Deere your privacy is important to us. We collect, use, and disclose your personal information in accordance with the John Deere privacy statement. For instance, we collect, use, and disclose your personal information to provide you with the products and services that you request; to communicate with you as our customer (examples include warranty and product improvement programs) and to meet safety and legal requirements; and for marketing and promotional purposes. Sometimes, we may ask our John Deere affiliates, dealers, or business partners to do work for us which involves your information. For complete details on your privacy rights and to obtain a copy of the John Deere Privacy Statement, please visit our website at <https://www.johndeere.com/>.

Warranty Duration

Unless otherwise provided in writing by John Deere, John Deere makes the following warranty to the first retail purchaser and each subsequent purchaser (if purchase is made prior to the expiration of applicable warranty) of each John Deere new off-highway engine marketed as part of a product manufactured by a company other than John Deere or its affiliates and on each John Deere engine used in an off-highway repower application:

- 12 months, unlimited hours of use, or
- 24 months and before the accumulation of 2000 hours of use.

NOTE: In the absence of a functional hourmeter, hours of use will be determined on the basis of 12 hours of use per calendar day.

Warranty Coverage

This warranty applies to the engine and to integral components and accessories sold by John Deere, and delivered to the first retail purchaser on or after 1 May 2010.

All John Deere-warranted parts and components of John Deere engines which, as delivered to the purchaser, are defective in materials and/or workmanship will be repaired or replaced, as John Deere elects. Warrantable repairs will be made without charge for parts or engine repair labor, including reasonable labor costs to remove and reinstall non-engine parts or components of the equipment in which the engine is installed. If required, reasonable labor costs for engine removal and reinstallation will also be included. All coverage is based on the defect appearing within the warranty period as measured from the date of delivery to the first retail purchaser.

Obtaining Warranty Service

Warranty service must be requested of the nearest authorized John Deere engine service outlet before the expiration of the warranty. An *authorized* service outlet is a John Deere engine distributor, a John Deere engine service dealer, or a John Deere equipment dealer selling and servicing equipment with an engine of the type covered by this warranty. (See When Warranty Service is Needed above.)

Authorized service outlets will use only new or remanufactured parts or components furnished or approved by John Deere.

NOTE: Authorized engine service locations are listed on the Internet at <https://www.johndeere.com/> (Click on "Dealer Locator").

At the time of requesting warranty service, the purchaser must be prepared to present evidence of the date of delivery of the engine.

John Deere reimburses authorized service outlets for limited travel expenses incurred in making warranty service repairs in non-John Deere applications when travel is actually performed. The limit, as of the date of publication of this booklet, is US\$400.00 (US\$500.00 if engine is marine) or equivalent. **If distances and travel times are greater than reimbursed by John Deere, the service outlet will charge the purchaser for the difference.**

Warranty Exclusions

John Deere's obligations will not apply to components and accessories which are not furnished or installed by John Deere, nor to failures caused by such items, except as required by law.

Purchaser's Responsibilities

The cost of normal maintenance and depreciation.

Periodic cleaning of the diesel particulate filter (DPF).

Consequences of negligence, misuse, or accident involving the product, or improper application, installation, or storage.

Consequences of service performed by someone other than an authorized John Deere engine service outlet.

Consequences of any product modification or alteration not approved by John Deere, including, but not limited to, tampering with engine fuel and air delivery systems.

Consequences of failure of non-product components.

Consequences of fuels, lubricants, or coolants that fail to meet the specifications and requirements listed in the Operator's Manual.

The effects of cooling system neglect as manifested in cylinder liner or cylinder block cavitation ("pitting", "erosion", "electrolysis").

Any premium for overtime labor requested by the purchaser.

Costs of transporting the product or the equipment in which it is installed to and from the location at which the warranty service is performed, if such costs are in excess of the travel reimbursement payable to the dealer had the warranty service been performed at the product's location.

Costs incurred in gaining access; for example, overcoming physical barriers such as walls, fences, floors, decks, or similar structures impeding access to the product, rental of cranes or similar, or construction of ramps or lifts or protective structures for product removal and reinstallation.

Incidental travel costs including meals, lodging, and similar, and any travel time or mileage costs in excess of the maximum allowance.

Service outlet costs incurred in solving or attempting to solve non-warrantable problems.

Services performed by a party other than an authorized John Deere service dealer.

Charges by dealers for initial start-up and inspection deemed unnecessary by John Deere when an Operator's Manual is supplied with the product are followed.

Costs related to interpretation or translation services.

No Representations or Implied Warranty

Where permitted by law, neither John Deere nor any company affiliated with it makes any guaranties, warranties, conditions, representations or promises, express or implied, oral or written, as to the nonoccurrence of any defect or the quality of performance of its engines other than those set forth in this booklet, and DOES NOT MAKE ANY IMPLIED WARRANTY OR CONDITIONS OF MERCHANTABILITY OR FITNESS otherwise provided for in the Uniform Commercial Code or required by any Sale of Goods Act or any other statute. This exclusion includes fundamental terms. In no event will a John Deere engine distributor or engine service dealer, John Deere equipment dealer, or John Deere or any company affiliated with John Deere be liable for incidental or consequential damages or injuries including, but not limited to, loss of profits, loss of crops, rental of substitute equipment or other commercial loss, damage to the equipment in which the engine is installed or for damage suffered by purchaser as a result of fundamental breaches of contract or breach of fundamental terms, unless such damages or injuries are caused by the gross negligence or intentional acts of the foregoing parties.

Remedy Limitation

The remedies set forth in this warranty are the purchaser's exclusive remedies in connection with the performance of, or any breach of guaranty, condition, or warranty in respect of new John Deere engines. In the event the above warranty fails to correct purchaser's performance problems caused by defects in workmanship and/or materials, purchaser's exclusive remedy shall be limited to payment by John Deere of actual damages in an amount not to exceed the cost of the engine.

No Seller's Warranty

No person or entity, other than John Deere, who sells the engine or product in which the engine has been installed makes any guaranty or warranty of its own on any engine warranted by John Deere unless it delivers to the purchaser a separate written guaranty certificate specifically guaranteeing the engine, in which case John Deere shall have no obligation to the purchaser. Neither original equipment manufacturers, engine or equipment distributors, engine or equipment dealers, nor any other person or entity, has any authority to make any representation or promise on behalf of John Deere or to modify the terms or limitations of this warranty in any way.

Replacement Parts Warranty

John Deere and John Deere Reman parts and components (excluding replacement engines) installed during engine warranty service are warranted for the remaining warranty period of the engine or the applicable warranty term for the installed service part, whichever is greater. A new or remanufactured engine replacing a failed engine under warranty is warranted for 90 days or the remaining warranty period of the original engine, whichever is greater.

Warranty Transfer

The remainder of the original engine warranty and the emissions control-related warranty may be transferred to a subsequent owner of the engine. The Engine Warranty Transfer card should be used to report the transfer to John Deere. If a card is not available, contact your Dealer or simply send the following information to JDPS Warranty Administration at Diesel-US@JohnDeere.com.

1. The complete 13-character engine serial number.
2. The name and mailing address of the original purchaser.
3. Delivery date to the original purchaser.
4. Hours at the time of transfer.
5. Date of transfer to the new owner.
6. Name and mailing address of the new owner.
7. How the engine/drivetrain being used, i.e., what equipment it powers, by manufacturer and model.
8. Equipment it powers, by manufacturer and model.

Purchased Extended Warranty

Extended warranty may be purchased on most engines in many areas of the world. John Deere engine distributors and equipment dealers, and dealers of manufacturers using John Deere engines in their products, have details. John Deere may also be contacted at U.S.A. fax number 1-309-749-0816, or in Europe fax number 33.2.38.84.62.66.

Emissions Warranties

Emissions warranties appear in the Operator's Manual furnished with the engine/machine. **(Warning: Statutes providing severe penalties for tampering with emissions controls may apply at the user's location.)** John Deere may also be contacted at U.S.A. fax number 1-309-749-0816; or in Europe fax number 33.2.38.84.62.66.

Local Warranty Requirements

Warranties required by local statutes will be furnished by the seller.

Option Codes (Engine Manufacturing Configuration)

When in need of engine replacement parts, your authorized John Deere service dealer will need to know the corresponding "Option Codes" for your engine. The option code label on the engine rocker arm cover may become damaged over time. By recording the four-digit codes when the engine is new, and storing this manual where it can be found when parts are needed, fast, accurate parts ordering and service will be assured. (See Engine Option Codes in the Record Keeping Section).

Should there be a question about an engine option code, note the engine serial number and call 1-800-JDENGINE from the U.S.A. or Canada, or fax U.S.A. number 1-309-749-0816; or E-mail at diesel-us@johndeere.com, Attention: Warranty Administration; or in Europe fax number 33.2.38.84.62.66, or E-mail at saranservice@johndeere.com.

Registering The Engine For Warranty

Completion and submission of the John Deere Engine Warranty Registration form (cut out sheet found in this manual) is very important. John Deere will not deny warranty service on an engine within its warranty period if the engine has not been registered. However, registering your engine will assure your servicing dealer that the engine is within the warranty period.

The easiest way to register your engine is via the Internet. Go to website <https://www.johndeere.com/enginewarranty> You can use the sheet in this manual to gather the information needed to register the warranty.

NOTE: Information provided on the form must be legible!

Typing is preferred, but legible handwritten reports are acceptable. "Block" numbers and Roman alphabet letters should be used. For example: 1,2,3,4 and A, B, C, D.

All requested information should be given. Much of it contributes to reports, including those required by governments.

The purchaser's telephone number or E-mail address allows John Deere to make contact should there be questions concerning the registration. The purchaser should sign and date the form.

JR74534,0000462 -19-05JUL16-3/3

Emissions Control System Certification Label

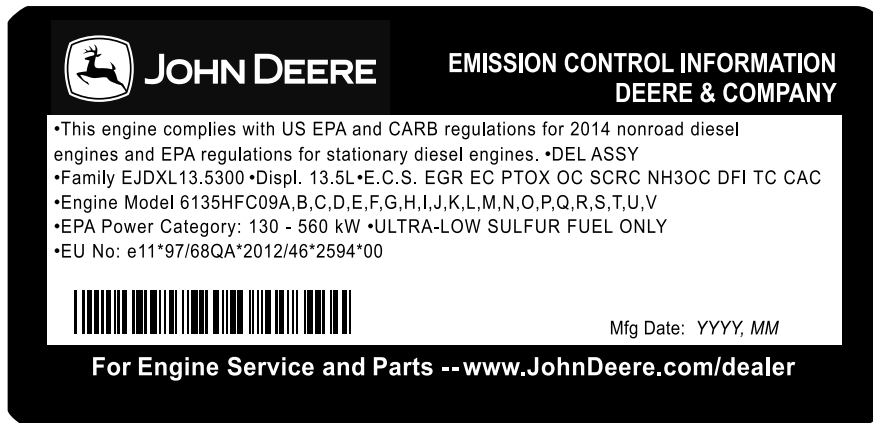

Engine Emissions Label

⚠ CAUTION: Statutes providing severe penalties for tampering with emissions controls may apply to the user or dealer.

The emissions warranty applies to those engines marketed by John Deere that have been certified by the United States Environmental Protection Agency (EPA) and/or California Air Resources Board (CARB); and used in the United States and Canada in Non-road equipment. The presence of an emissions label like the one shown signifies that the engine has been certified with the EPA and/or CARB. The EPA and CARB warranties only apply to new engines having the certification label affixed to the engine and sold as stated above in the geographic areas. The presence of an EU number signifies that the engine has been certified with the European Union countries per Directive 97/68/EC. The EPA and/or CARB emissions warranties do not apply to the EU countries.

The emissions label has applicable US EPA and/or CARB regulatory year. The regulatory year determines which warranty statement is applicable to engine. See "EPA Non-road Emissions Control Warranty Statement—Compression Ignition" and "CARB Non-road Emissions Control Warranty Statement—Compression Ignition". For additional regulatory year warranty statements, see www.JohnDeere.com or contact the nearest John Deere service dealer for assistance.

Emission Control System(s) Laws

The U.S. EPA and California ARB prohibit the removal or rendering inoperative of any device or element of design installed on or in engines/equipment in compliance with applicable emission regulations prior to or after the sale and delivery of the engines/equipment to the ultimate purchaser.

DX,EMISSIONS,LABEL -19-01AUG14-1/1

RG24291 —UN—18SEP13

EPA Non-road Emissions Control Warranty Statement—Compression Ignition

DXLOGOV1 —UN—28APR09



JOHN DEERE

U.S. AND CANADA EMISSION CONTROL WARRANTY STATEMENT YOUR WARRANTY RIGHTS AND OBLIGATIONS

To determine if the John Deere engine qualifies for the additional warranties set forth below, look for the "Emissions Control Information" label located on the engine. If the engine is operated in the United States or Canada and the Emissions Control information label states: "This engine complies with US EPA regulations for nonroad and stationary diesel engines", or "This engine conforms to US EPA nonroad compression-ignition regulations", refer to the "U.S. and Canada Emission Control Warranty Statement." If the engine is operated in California, and the label states: "This engine complies with US EPA and CARB regulations for nonroad diesel engines", or "This engine conforms to US EPA and California nonroad compression-ignition emission regulations", also refer to the "California Emission Control Warranty Statement."

Warranties stated on this certificate refer only to emissions-related parts and components of your engine. The complete engine warranty, less emissions-related parts and components, is provided separately. If you have any questions about your warranty rights and responsibilities, you should contact John Deere at 1-319-292-5400.

JOHN DEERE'S WARRANTY RESPONSIBILITY

John Deere warrants to the ultimate purchaser and each subsequent purchaser that this off-road diesel engine including all parts of its emission-control system was designed, built and equipped so as to conform at the time of the sale with Section 213 of the Clean Air Act and is free from defects in materials and workmanship which would cause the engine to fail to conform with applicable US EPA regulations for a period of five years from the date the engine is placed into service or 3,000 hours of operation, whichever first occurs.

Where a warrantable condition exists, John Deere will repair or replace, as it elects, any part or component with a defect in materials or workmanship that would increase the engine's emissions of any regulated pollutant within the stated warranty period at no cost to you, including expenses related to diagnosing and repairing or replacing emission-related parts. Warranty coverage is subject to the limitations and exclusions set forth herein. Emission-related components include engine parts developed to control emissions related to the following:

Air-Induction System	Aftertreatment Devices
Fuel System	Crankcase Ventilation Valves
Ignition System	Sensors
Exhaust Gas Recirculation Systems	Engine Electronic Control Units

EMISSION WARRANTY EXCLUSIONS

John Deere may deny warranty claims for malfunctions or failures caused by:

- Non-performance of maintenance requirements listed in the Operator's Manual
- The use of the engine/equipment in a manner for which it was not designed
- Abuse, neglect, improper maintenance or unapproved modifications or alterations
- Accidents for which it does not have responsibility or by acts of God

The off-road diesel engine is designed to operate on diesel fuel as specified in the Fuels, Lubricants and Coolants section in the Operators Manual. Use of any other fuel can harm the emissions control system of the engine/equipment and is not approved for use.

To the extent permitted by law John Deere is not liable for damage to other engine components caused by a failure of an emission-related part, unless otherwise covered by standard warranty.

THIS WARRANTY IS EXPRESSLY IN LIEU OF ANY OTHER WARRANTIES, EXPRESS OR IMPLIED, INCLUDING ANY WARRANTY OF MERCHANTABILITY OR FITNESS FOR A PARTICULAR PURPOSE. REMEDIES UNDER THIS WARRANTY ARE LIMITED TO THE PROVISIONS OF MATERIAL AND SERVICES AS SPECIFIED HEREIN. WHERE PERMITTED BY LAW, NEITHER JOHN DEERE NOR ANY AUTHORIZED JOHN DEERE ENGINE DISTRIBUTOR, DEALER, OR REPAIR FACILITY OR ANY COMPANY AFFILIATED WITH JOHN DEERE WILL BE LIABLE FOR INCIDENTAL OR CONSEQUENTIAL DAMAGES.

Emission_CI_EPA (18Dec09)

Continued on next page

DX,EMISSIONS,EPA -19-12DEC12-1/2



JOHN DEERE

**U.S. AND CANADA EMISSION CONTROL WARRANTY STATEMENT
YOUR WARRANTY RIGHTS AND OBLIGATIONS**

To determine if the John Deere engine qualifies for the additional warranties set forth below, look for the "Emissions Control Information" label located on the engine. If the engine is operated in the United States or Canada and the Emissions Control information label states: "This engine complies with US EPA regulations for nonroad and stationary diesel engines", or "This engine conforms to US EPA nonroad compression-ignition regulations", refer to the "U.S. and Canada Emission Control Warranty Statement." If the engine is operated in California, and the label states: "This engine complies with US EPA and CARB regulations for nonroad diesel engines", or "This engine conforms to US EPA and California nonroad compression-ignition emission regulations", also refer to the "California Emission Control Warranty Statement."

Warranties stated on this certificate refer only to emissions-related parts and components of your engine. The complete engine warranty, less emissions-related parts and components, is provided separately. If you have any questions about your warranty rights and responsibilities, you should contact John Deere at 1-319-292-5400.

JOHN DEERE'S WARRANTY RESPONSIBILITY

John Deere warrants to the ultimate purchaser and each subsequent purchaser that this off-road diesel engine including all parts of its emission-control system was designed, built and equipped so as to conform at the time of the sale with Section 213 of the Clean Air Act and is free from defects in materials and workmanship which would cause the engine to fail to conform with applicable US EPA regulations for a period of five years from the date the engine is placed into service or 3,000 hours of operation, whichever first occurs.

Where a warrantable condition exists, John Deere will repair or replace, as it elects, any part or component with a defect in materials or workmanship that would increase the engine's emissions of any regulated pollutant within the stated warranty period at no cost to you, including expenses related to diagnosing and repairing or replacing emission-related parts. Warranty coverage is subject to the limitations and exclusions set forth herein. Emission-related components include engine parts developed to control emissions related to the following:

- | | |
|-----------------------------------|---------------------------------|
| Air-Induction System | Aftertreatment Devices |
| Fuel System | Crankcase Ventilation Valves |
| Ignition System | Sensors |
| Exhaust Gas Recirculation Systems | Engine Electronic Control Units |

EMISSION WARRANTY EXCLUSIONS

John Deere may deny warranty claims for malfunctions or failures caused by:

- Non-performance of maintenance requirements listed in the Operator's Manual
- The use of the engine/equipment in a manner for which it was not designed
- Abuse, neglect, improper maintenance or unapproved modifications or alterations
- Accidents for which it does not have responsibility or by acts of God

The off-road diesel engine is designed to operate on diesel fuel as specified in the Fuels, Lubricants and Coolants section in the Operators Manual. Use of any other fuel can harm the emissions control system of the engine/equipment and is not approved for use.

To the extent permitted by law John Deere is not liable for damage to other engine components caused by a failure of an emission-related part, unless otherwise covered by standard warranty.

THIS WARRANTY IS EXPRESSLY IN LIEU OF ANY OTHER WARRANTIES, EXPRESS OR IMPLIED, INCLUDING ANY WARRANTY OF MERCHANTABILITY OR FITNESS FOR A PARTICULAR PURPOSE. REMEDIES UNDER THIS WARRANTY ARE LIMITED TO THE PROVISIONS OF MATERIAL AND SERVICES AS SPECIFIED HEREIN. WHERE PERMITTED BY LAW, NEITHER JOHN DEERE NOR ANY AUTHORIZED JOHN DEERE ENGINE DISTRIBUTOR, DEALER, OR REPAIR FACILITY OR ANY COMPANY AFFILIATED WITH JOHN DEERE WILL BE LIABLE FOR INCIDENTAL OR CONSEQUENTIAL DAMAGES.

Emission_CI_EPA (18Dec09)

DX,EMISSIONS,EPA -19-12DEC12-2/2

TS1721—UN—15JUL13

CARB Non-road Emissions Control Warranty Statement—Compression Ignition

Emissions Control Warranty Statement 2016 through 2018

DXLOGOV1 —UN—28APR09



JOHN DEERE

CALIFORNIA EMISSIONS CONTROL WARRANTY STATEMENT YOUR WARRANTY RIGHTS AND OBLIGATIONS

To determine if the John Deere engine qualifies for the additional warranties set forth below, look for the "Emission Control Information" label located on the engine. If the engine is operated in the United States or Canada and the engine label states: "This engine complies with US EPA regulations for nonroad and stationary diesel engines", or "This engine complies with US EPA regulations for stationary emergency diesel engines", refer to the "U.S. and Canada Emission Control Warranty Statement." If the engine is operated in California, and the engine label states: "This engine complies with US EPA and CARB regulations for nonroad diesel engines" also refer to the "California Emissions Control Warranty Statement."

Warranties stated on this certificate refer only to emissions-related parts and components of your engine. The complete engine warranty, less emission-related parts and components, is provided separately. If you have any questions about your warranty rights and responsibilities, you should contact John Deere at 1-319-292-5400.

CALIFORNIA EMISSIONS CONTROL WARRANTY STATEMENT:

The California Air Resources Board (CARB) is pleased to explain the emission-control system warranty on 2016 through 2018 off-road diesel engines. In California, new off-road engines must be designed, built and equipped to meet the State's stringent anti-smog standards. John Deere must warrant the emission control system on your engine for the periods of time listed below provided there has been no abuse, neglect or improper maintenance of your engine.

Your emission control system may include parts such as the fuel injection system and the air induction system. Also included may be hoses, belts, connectors and other emission-related assemblies.

John Deere warrants to the ultimate purchaser and each subsequent purchaser that this off-road diesel engine was designed, built, and equipped so as to conform at the time of sale with all applicable regulations adopted by CARB and is free from defects in materials and workmanship which would cause the failure of a warranted part to be identical in all material respects to the part as described in John Deere's application for certification for a period of five years from the date the engine is delivered to an ultimate purchaser or 3,000 hours of operation, whichever occurs first for all engines rated at 19 kW and greater. In the absence of a device to measure hours of use, the engine shall be warranted for a period of five years.

EMISSIONS WARRANTY EXCLUSIONS:

John Deere may deny warranty claims for failures caused by the use of an add-on or modified part which has not been exempted by the CARB. A modified part is an aftermarket part intended to replace an original emission-related part which is not functionally identical in all respects and which in any way affects emissions. An add-on part is any aftermarket part which is not a modified part or a replacement part.

In no event will John Deere, any authorized engine distributor, dealer, or repair facility, or any company affiliated with John Deere be liable for incidental or consequential damage.

Continued on next page

DX,EMISSIONS,CARB -19-03FEB17-1/8

Warranty

JOHN DEERE'S WARRANTY RESPONSIBILITY:

Where a warrantable condition exists, John Deere will repair or replace, as it elects, your off-road diesel engine at no cost to you, including diagnosis, parts or labor. Warranty coverage is subject to the limitations and exclusions set forth herein. The off-road diesel engine is warranted for a period of five years from the date the engine is delivered to an ultimate purchaser or 3,000 hours of operation, whichever occurs first. The following are emissions-related parts:

Air Induction System

- Intake manifold
- Turbocharger
- Charge air cooler

Fuel Metering system

- Fuel injection system

Exhaust Gas Recirculation

- EGR valve

Catalyst or Thermal Reactor Systems

- Catalytic converter
- Exhaust manifold

Emission control labels

Particulate Controls

- Any device used to capture particulate emissions
- Any device used in the regeneration of the capturing system
- Enclosures and manifolding
- Smoke Puff Limiters

Positive Crankcase Ventilation (PCV) System

- PCV valve
- Oil filler cap

Advanced Oxides of Nitrogen (NOx) Controls

- NOx absorbers and catalysts

SCR systems and urea containers/dispensing systems

Miscellaneous Items used in Above Systems

- Electronic control units, sensors, actuators, wiring harnesses, hoses, connectors, clamps, fittings, gasket, mounting hardware

Any warranted emissions-related part scheduled for replacement as required maintenance is warranted by John Deere for the period of time prior to the first scheduled replacement point for the part. Any warranted emissions-related part not scheduled for replacement as required maintenance or scheduled only for regular inspection is warranted by John Deere for the stated warranty period.

OWNER'S WARRANTY RESPONSIBILITIES:

As the off-road diesel engine owner you are responsible for the performance of the required maintenance listed in your Operator's Manual. John Deere recommends that the owner retain all receipts covering maintenance on the off-road diesel engine, but John Deere cannot deny warranty solely for the lack of receipts or for the owner's failure to ensure the performance of all scheduled maintenance. However, as the off-road diesel engine owner, you should be aware that John Deere may deny you warranty coverage if your off-road diesel engine or a part has failed due to abuse, neglect, improper maintenance or unapproved modifications.

The off-road diesel engine is designed to operate on diesel fuel as specified in the Fuels, Lubricants and Coolants section in the Operators Manual. Use of any other fuel may result in the engine no longer operating in compliance with applicable emissions requirements.

The owner is responsible for initiating the warranty process, and should present the machine to the nearest authorized John Deere dealer as soon as a problem is suspected. The warranty repairs should be completed by the authorized John Deere dealer as quickly as possible.

Emissions regulations require the customer to bring the unit to an authorized servicing dealer when warranty service is required. As a result, John Deere is NOT liable for travel or mileage on emissions warranty service calls.

Emission_CI_CARB (13Jun14)

Continued on next page

DX,EMISSIONS,CARB -19-03FEB17-2/8

Emissions Control Warranty Statement 2016 through 2018

DXLOGOV1 —UN—28APR09



JOHN DEERE

CALIFORNIA EMISSIONS CONTROL WARRANTY STATEMENT YOUR WARRANTY RIGHTS AND OBLIGATIONS

To determine if the John Deere engine qualifies for the additional warranties set forth below, look for the "Emission Control Information" label located on the engine. If the engine is operated in the United States or Canada and the engine label states: "This engine complies with US EPA regulations for nonroad and stationary diesel engines", or "This engine complies with US EPA regulations for stationary emergency diesel engines", refer to the "U.S. and Canada Emission Control Warranty Statement." If the engine is operated in California, and the engine label states: "This engine complies with US EPA and CARB regulations for nonroad diesel engines" also refer to the "California Emissions Control Warranty Statement."

Warranties stated on this certificate refer only to emissions-related parts and components of your engine. The complete engine warranty, less emission-related parts and components, is provided separately. If you have any questions about your warranty rights and responsibilities, you should contact John Deere at 1-319-292-5400.

CALIFORNIA EMISSIONS CONTROL WARRANTY STATEMENT:

The California Air Resources Board (CARB) is pleased to explain the emission-control system warranty on 2016 through 2018 off-road diesel engines. In California, new off-road engines must be designed, built and equipped to meet the State's stringent anti-smog standards. John Deere must warrant the emission control system on your engine for the periods of time listed below provided there has been no abuse, neglect or improper maintenance of your engine.

Your emission control system may include parts such as the fuel injection system and the air induction system. Also included may be hoses, belts, connectors and other emission-related assemblies.

John Deere warrants to the ultimate purchaser and each subsequent purchaser that this off-road diesel engine was designed, built, and equipped so as to conform at the time of sale with all applicable regulations adopted by CARB and is free from defects in materials and workmanship which would cause the failure of a warranted part to be identical in all material respects to the part as described in John Deere's application for certification for a period of five years from the date the engine is delivered to an ultimate purchaser or 3,000 hours of operation, whichever occurs first for all engines rated at 19 kW and greater. In the absence of a device to measure hours of use, the engine shall be warranted for a period of five years.

EMISSIONS WARRANTY EXCLUSIONS:

John Deere may deny warranty claims for failures caused by the use of an add-on or modified part which has not been exempted by the CARB. A modified part is an aftermarket part intended to replace an original emission-related part which is not functionally identical in all respects and which in any way affects emissions. An add-on part is any aftermarket part which is not a modified part or a replacement part.

In no event will John Deere, any authorized engine distributor, dealer, or repair facility, or any company affiliated with John Deere be liable for incidental or consequential damage.

Continued on next page

DX,EMISSIONS,CARB -19-03FEB17-3/8

RG26035 —UN—24JUN14

Warranty

JOHN DEERE'S WARRANTY RESPONSIBILITY:

Where a warrantable condition exists, John Deere will repair or replace, as it elects, your off-road diesel engine at no cost to you, including diagnosis, parts or labor. Warranty coverage is subject to the limitations and exclusions set forth herein. The off-road diesel engine is warranted for a period of five years from the date the engine is delivered to an ultimate purchaser or 3,000 hours of operation, whichever occurs first. The following are emissions-related parts:

Air Induction System

- Intake manifold
- Turbocharger
- Charge air cooler

Fuel Metering system

- Fuel injection system

Exhaust Gas Recirculation

- EGR valve

Catalyst or Thermal Reactor Systems

- Catalytic converter
- Exhaust manifold

Emission control labels

Particulate Controls

- Any device used to capture particulate emissions
- Any device used in the regeneration of the capturing system
- Enclosures and manifolding
- Smoke Puff Limiters

Positive Crankcase Ventilation (PCV) System

- PCV valve
- Oil filler cap

Advanced Oxides of Nitrogen (NOx) Controls

- NOx absorbers and catalysts

SCR systems and urea containers/dispensing systems

Miscellaneous Items used in Above Systems

- Electronic control units, sensors, actuators, wiring harnesses, hoses, connectors, clamps, fittings, gasket, mounting hardware

Any warranted emissions-related part scheduled for replacement as required maintenance is warranted by John Deere for the period of time prior to the first scheduled replacement point for the part. Any warranted emissions-related part not scheduled for replacement as required maintenance or scheduled only for regular inspection is warranted by John Deere for the stated warranty period.

OWNER'S WARRANTY RESPONSIBILITIES:

As the off-road diesel engine owner you are responsible for the performance of the required maintenance listed in your Operator's Manual. John Deere recommends that the owner retain all receipts covering maintenance on the off-road diesel engine, but John Deere cannot deny warranty solely for the lack of receipts or for the owner's failure to ensure the performance of all scheduled maintenance. However, as the off-road diesel engine owner, you should be aware that John Deere may deny you warranty coverage if your off-road diesel engine or a part has failed due to abuse, neglect, improper maintenance or unapproved modifications.

The off-road diesel engine is designed to operate on diesel fuel as specified in the Fuels, Lubricants and Coolants section in the Operators Manual. Use of any other fuel may result in the engine no longer operating in compliance with applicable emissions requirements.

The owner is responsible for initiating the warranty process, and should present the machine to the nearest authorized John Deere dealer as soon as a problem is suspected. The warranty repairs should be completed by the authorized John Deere dealer as quickly as possible.

Emissions regulations require the customer to bring the unit to an authorized servicing dealer when warranty service is required. As a result, John Deere is NOT liable for travel or mileage on emissions warranty service calls.

Emission_CI_CARB (13Jun14)

Continued on next page

DX,EMISSIONS,CARB -19-03FEB17-4/8

RG26036—UN—24JUN14

Emissions Control Warranty Statement 2019 through 2021

DXLOGOV1 —UN—28APR09



JOHN DEERE

CALIFORNIA EMISSIONS CONTROL WARRANTY STATEMENT YOUR WARRANTY RIGHTS AND OBLIGATIONS

To determine if the John Deere engine qualifies for the additional warranties set forth below, look for the "Emission Control Information" label located on the engine. If the engine is operated in the United States or Canada and the engine label states: "This engine complies with US EPA regulations for nonroad and stationary diesel engines", or "This engine complies with US EPA regulations for stationary emergency diesel engines", refer to the "U.S. and Canada Emission Control Warranty Statement." If the engine is operated in California, and the engine label states: "This engine complies with US EPA and CARB regulations for nonroad diesel engines" also refer to the "California Emissions Control Warranty Statement."

Warranties stated on this certificate refer only to emissions-related parts and components of your engine. The complete engine warranty, less emission-related parts and components, is provided separately. If you have any questions about your warranty rights and responsibilities, you should contact John Deere at 1-319-292-5400.

CALIFORNIA EMISSIONS CONTROL WARRANTY STATEMENT:

The California Air Resources Board (CARB) is pleased to explain the emission-control system warranty on 2019 through 2021 off-road diesel engines. In California, new off-road engines must be designed, built and equipped to meet the State's stringent anti-smog standards. John Deere must warrant the emission control system on your engine for the periods of time listed below provided there has been no abuse, neglect or improper maintenance of your engine.

Your emission control system may include parts such as the fuel injection system and the air induction system. Also included may be hoses, belts, connectors and other emission-related assemblies.

John Deere warrants to the ultimate purchaser and each subsequent purchaser that this off-road diesel engine was designed, built, and equipped so as to conform at the time of sale with all applicable regulations adopted by CARB and is free from defects in materials and workmanship which would cause the failure of a warranted part to be identical in all material respects to the part as described in John Deere's application for certification for a period of five years from the date the engine is delivered to an ultimate purchaser or 3,000 hours of operation, whichever occurs first for all engines rated at 19 kW and greater. In the absence of a device to measure hours of use, the engine shall be warranted for a period of five years.

EMISSIONS WARRANTY EXCLUSIONS:

John Deere may deny warranty claims for failures caused by the use of an add-on or modified part which has not been exempted by the CARB. A modified part is an aftermarket part intended to replace an original emission-related part which is not functionally identical in all respects and which in any way affects emissions. An add-on part is any aftermarket part which is not a modified part or a replacement part.

In no event will John Deere, any authorized engine distributor, dealer, or repair facility, or any company affiliated with John Deere be liable for incidental or consequential damage.

Continued on next page

DX,EMISSIONS,CARB -19-03FEB17-5/8

Warranty

JOHN DEERE'S WARRANTY RESPONSIBILITY:

Where a warrantable condition exists, John Deere will repair or replace, as it elects, your off-road diesel engine at no cost to you, including diagnosis, parts or labor. Warranty coverage is subject to the limitations and exclusions set forth herein. The off-road diesel engine is warranted for a period of five years from the date the engine is delivered to an ultimate purchaser or 3,000 hours of operation, whichever occurs first. The following are emissions-related parts:

Air Induction System

- Intake manifold
- Turbocharger
- Charge air cooler

Fuel Metering system

- Fuel injection system

Exhaust Gas Recirculation

- EGR valve

Catalyst or Thermal Reactor Systems

- Catalytic converter
- Exhaust manifold

Emission control labels

Particulate Controls

- Any device used to capture particulate emissions
- Any device used in the regeneration of the capturing system
- Enclosures and manifolding
- Smoke Puff Limiters

Positive Crankcase Ventilation (PCV) System

- PCV valve
- Oil filler cap

Advanced Oxides of Nitrogen (NOx) Controls

- NOx absorbers and catalysts

SCR systems and urea containers/dispensing systems

Miscellaneous Items used in Above Systems

- Electronic control units, sensors, actuators, wiring harnesses, hoses, connectors, clamps, fittings, gasket, mounting hardware

Any warranted emissions-related part scheduled for replacement as required maintenance is warranted by John Deere for the period of time prior to the first scheduled replacement point for the part. Any warranted emissions-related part not scheduled for replacement as required maintenance or scheduled only for regular inspection is warranted by John Deere for the stated warranty period.

OWNER'S WARRANTY RESPONSIBILITIES:

As the off-road diesel engine owner you are responsible for the performance of the required maintenance listed in your Operator's Manual. John Deere recommends that the owner retain all receipts covering maintenance on the off-road diesel engine, but John Deere cannot deny warranty solely for the lack of receipts or for the owner's failure to ensure the performance of all scheduled maintenance. However, as the off-road diesel engine owner, you should be aware that John Deere may deny you warranty coverage if your off-road diesel engine or a part has failed due to abuse, neglect, improper maintenance or unapproved modifications.

The off-road diesel engine is designed to operate on diesel fuel as specified in the Fuels, Lubricants and Coolants section in the Operators Manual. Use of any other fuel may result in the engine no longer operating in compliance with applicable emissions requirements.

The owner is responsible for initiating the warranty process, and should present the machine to the nearest authorized John Deere dealer as soon as a problem is suspected. The warranty repairs should be completed by the authorized John Deere dealer as quickly as possible.

Emissions regulations require the customer to bring the unit to an authorized servicing dealer when warranty service is required. As a result, John Deere is NOT liable for travel or mileage on emissions warranty service calls.

Emission_CI_CARB (01Feb17)

Continued on next page

DX,EMISSIONS,CARB -19-03FEB17-6/8

Emissions Control Warranty Statement 2019 through 2021

DXLOGOV1 —UN—28APR09



JOHN DEERE

**CALIFORNIA EMISSIONS CONTROL WARRANTY STATEMENT
YOUR WARRANTY RIGHTS AND OBLIGATIONS**

To determine if the John Deere engine qualifies for the additional warranties set forth below, look for the "Emission Control Information" label located on the engine. If the engine is operated in the United States or Canada and the engine label states: "This engine complies with US EPA regulations for nonroad and stationary diesel engines", or "This engine complies with US EPA regulations for stationary emergency diesel engines", refer to the "U.S. and Canada Emission Control Warranty Statement." If the engine is operated in California, and the engine label states: "This engine complies with US EPA and CARB regulations for nonroad diesel engines" also refer to the "California Emissions Control Warranty Statement."

Warranties stated on this certificate refer only to emissions-related parts and components of your engine. The complete engine warranty, less emission-related parts and components, is provided separately. If you have any questions about your warranty rights and responsibilities, you should contact John Deere at 1-319-292-5400.

CALIFORNIA EMISSIONS CONTROL WARRANTY STATEMENT:

The California Air Resources Board (CARB) is pleased to explain the emission-control system warranty on 2019 through 2021 off-road diesel engines. In California, new off-road engines must be designed, built and equipped to meet the State's stringent anti-smog standards. John Deere must warrant the emission control system on your engine for the periods of time listed below provided there has been no abuse, neglect or improper maintenance of your engine.

Your emission control system may include parts such as the fuel injection system and the air induction system. Also included may be hoses, belts, connectors and other emission-related assemblies.

John Deere warrants to the ultimate purchaser and each subsequent purchaser that this off-road diesel engine was designed, built, and equipped so as to conform at the time of sale with all applicable regulations adopted by CARB and is free from defects in materials and workmanship which would cause the failure of a warranted part to be identical in all material respects to the part as described in John Deere's application for certification for a period of five years from the date the engine is delivered to an ultimate purchaser or 3,000 hours of operation, whichever occurs first for all engines rated at 19 kW and greater. In the absence of a device to measure hours of use, the engine shall be warranted for a period of five years.

EMISSIONS WARRANTY EXCLUSIONS:

John Deere may deny warranty claims for failures caused by the use of an add-on or modified part which has not been exempted by the CARB. A modified part is an aftermarket part intended to replace an original emission-related part which is not functionally identical in all respects and which in any way affects emissions. An add-on part is any aftermarket part which is not a modified part or a replacement part.

In no event will John Deere, any authorized engine distributor, dealer, or repair facility, or any company affiliated with John Deere be liable for incidental or consequential damage.

Continued on next page

DX,EMISSIONS,CARB -19-03FEB17-7/8

RG29280 —UN—02FEB17

Warranty

JOHN DEERE'S WARRANTY RESPONSIBILITY:

Where a warrantable condition exists, John Deere will repair or replace, as it elects, your off-road diesel engine at no cost to you, including diagnosis, parts or labor. Warranty coverage is subject to the limitations and exclusions set forth herein. The off-road diesel engine is warranted for a period of five years from the date the engine is delivered to an ultimate purchaser or 3,000 hours of operation, whichever occurs first. The following are emissions-related parts:

Air Induction System

- Intake manifold
- Turbocharger
- Charge air cooler

Fuel Metering system

- Fuel injection system

Exhaust Gas Recirculation

- EGR valve

Catalyst or Thermal Reactor Systems

- Catalytic converter
- Exhaust manifold

Emission control labels

Particulate Controls

- Any device used to capture particulate emissions
- Any device used in the regeneration of the capturing system
- Enclosures and manifolding
- Smoke Puff Limiters

Positive Crankcase Ventilation (PCV) System

- PCV valve
- Oil filler cap

Advanced Oxides of Nitrogen (NOx) Controls

- NOx absorbers and catalysts

SCR systems and urea containers/dispensing systems

Miscellaneous Items used in Above Systems

- Electronic control units, sensors, actuators, wiring harnesses, hoses, connectors, clamps, fittings, gasket, mounting hardware

Any warranted emissions-related part scheduled for replacement as required maintenance is warranted by John Deere for the period of time prior to the first scheduled replacement point for the part. Any warranted emissions-related part not scheduled for replacement as required maintenance or scheduled only for regular inspection is warranted by John Deere for the stated warranty period.

OWNER'S WARRANTY RESPONSIBILITIES:

As the off-road diesel engine owner you are responsible for the performance of the required maintenance listed in your Operator's Manual. John Deere recommends that the owner retain all receipts covering maintenance on the off-road diesel engine, but John Deere cannot deny warranty solely for the lack of receipts or for the owner's failure to ensure the performance of all scheduled maintenance. However, as the off-road diesel engine owner, you should be aware that John Deere may deny you warranty coverage if your off-road diesel engine or a part has failed due to abuse, neglect, improper maintenance or unapproved modifications.

The off-road diesel engine is designed to operate on diesel fuel as specified in the Fuels, Lubricants and Coolants section in the Operators Manual. Use of any other fuel may result in the engine no longer operating in compliance with applicable emissions requirements.

The owner is responsible for initiating the warranty process, and should present the machine to the nearest authorized John Deere dealer as soon as a problem is suspected. The warranty repairs should be completed by the authorized John Deere dealer as quickly as possible.

Emissions regulations require the customer to bring the unit to an authorized servicing dealer when warranty service is required. As a result, John Deere is NOT liable for travel or mileage on emissions warranty service calls.

Emission_CI_CARB (01Feb17)

DX,EMISSIONS,CARB -19-03FEB17-8/8

RG29281 —UN—27FEB17

John Deere Service Literature Available

Technical Information

Technical information can be purchased from John Deere. Publications are available in print or CD-ROM format.

Orders can be made using one of the following:

- John Deere Technical Information Store:
www.JohnDeere.com/TechInfoStore
- Call 1-800-522-7448
- Contact your John Deere dealer

Available information includes:

PARTS CATALOGS list service parts available for your machine with exploded view illustrations to help you identify the correct parts. It is also useful in assembling and disassembling.



TS189 —UN—17JAN89

DX.SERVLIT -19-07DEC16-1/4

OPERATOR'S MANUALS providing safety, operating, maintenance, and service information.



TS191 —UN—02DEC88

DX.SERVLIT -19-07DEC16-2/4

TECHNICAL MANUALS outlining service information for your machine. Included are specifications, illustrated assembly and disassembly procedures, hydraulic oil flow diagrams, and wiring diagrams. Some products have separate manuals for repair and diagnostic information. Some components, such as engines, are available in a separate component technical manual.



TS224 —UN—17JAN89

Continued on next page

DX.SERVLIT -19-07DEC16-3/4

EDUCATIONAL CURRICULUM including five comprehensive series of books detailing basic information regardless of manufacturer:

- Agricultural Primer series covers technology in farming and ranching.
- Farm Business Management series examines “real-world” problems and offers practical solutions in the areas of marketing, financing, equipment selection, and compliance.
- Fundamentals of Services manuals show you how to repair and maintain off-road equipment.
- Fundamentals of Machine Operation manuals explain machine capacities and adjustments, how to improve machine performance, and how to eliminate unnecessary field operations.
- Fundamentals of Compact Equipment manuals provide instruction in servicing and maintaining equipment up to 40 PTO horsepower.



TS1663—UN—10OCT97

DX.SERVLIT -19-07DEC16-4/4

	Page		Page
Extended service intervals	10-9		
Engine speed, changing	15-10		
F		L	
Fan belts	45-7	Long-term storage	
Filter, Air, Replacement	45-6	Preparing engine	55-1
Filter, replace		Lubricant	
Fuel	35-2	Mixing	10-9
Oil	30-1	Lubricant Storage	
Fire extinguisher, service	30-1	Storage, Lubricant	10-10
Fuel		Lubricants, safety	10-9
Aviation	10-4	Lubrication and maintenance	
Biodiesel	10-3	As required	
Burner	10-4	Pre-start cleaning guide	45-3
Diesel	10-1	Lubrication and Maintenance	
Handling and storing	10-2	Service Interval Chart	20-2
Jet	10-4	Lubrication and Maintenance Records	65-1
Kerosene	10-4	Lubricity of diesel fuel	10-2
Lubricity	10-2	M	
Fuel filter		Maintenance Records	65-1
Checking	25-1	Manual belt tensioner	30-5
Draining water	25-1	Manual belt tensioner - using belt tension tool	30-6
Replace	35-2	Metric bolt and screw torque values	60-18
Fuel Filters		Mixing lubricants	10-9
Filters, Fuel	10-5	Mounts, engine	
Fuel injection pump model number	01-4	Checking	30-3
Fuel system		O	
Bleeding	45-9	Oil	
Fuses, checking	45-8	Dipstick	25-1
G		Engine	
Gauge panel	15-2, 15-3	Non-Emissions certified and certified	
Gauges	15-2, 15-3, 15-8	tier 1 and stage I	10-8
H		Fill quantity	60-16
Hand throttle	15-2, 15-3	Filler locations	25-1
Hardware torque values		Oil filter, change	30-1
Metric	60-18	Oil filters	10-10
Unified inch	60-17	Oil pressure gauge	15-2, 15-3
I		Operating engine	
Idling engine	15-10	Break-in	15-4
Instrument panels	15-2, 15-3	Cold weather	15-9
J		Normal operation	15-8
Jet fuels	10-4	P	
K		Poly-vee belts	
Key switch	15-2, 15-3	Replace	45-7
		Power ratings	60-9
		4.5 L	60-2
		6.8 L	60-6
		Pre start cleaning	
		Guide	45-3
		Proposition 65	05-2

Continued on next page

	Page		Page
R		Removing from.....	55-2
Radiator cap testing.....	35-9	Storing fuel	10-2
Recordkeeping		Supplemental coolant additives	
Engine serial number.....	01-1	Replenishing	35-7
Injection pump model number.....	01-4	T	
Refueling, avoid static electricity risk.....	05-6	Temperature gauge (coolant)	15-2, 15-3
Registration	-3	Tensioner, belt	
S		Automatic.....	35-4
Safety		Manual	30-5
Protect against noise	05-7	Testing diesel fuel	10-4
Safe maintenance, practice	05-9	Thermostat	
Safety, Avoid High-Pressure Fluids		Install.....	40-6
Avoid High-Pressure Fluids	05-10	Remove.....	40-6
Safety, Handle Fuel Safely, Avoid Fires		Test opening temperature	40-6
Avoid Fires, Handle Fuel Safely.....	05-4	Torque charts	
Safety, lubricants	10-9	Metric	60-18
Serial number		Unified inch	60-17
Engine.....	01-1	Trademarks	-7
Fuel injection pump.....	01-4	Troubleshooting	
Service		General, engine	50-6
As required		U	
Pre-start cleaning guide	45-3	Unified inch bolt and screw torque values	60-17
Battery.....	30-3	V	
Fire extinguisher	30-1	Valves	
Service intervals		Clearance, check and adjust.....	40-9
Extended diesel engine oil		Vibration damper	40-3
Non-Emissions certified and certified		W	
tier 1 and stage I.....	10-9	Warming engine	15-8
Signal words, understand	05-1	Warranty	
Specifications		Non-road emissions control warranty	
4.5 L.....	60-1	statement--compression ignition	
6.8 L.....	60-1	CARB	70-7
Battery capabilities.....	30-3	EPA	70-5
Belt tensioner	35-4	OEM applications.....	70-1
Damper	40-3	Wiring diagram	
Engine crankcase oil fill	60-16	Except North America	50-4
Fuel injection pump.....	60-9	North America	50-2
4.5 L	60-2		
6.8 L	60-6		
Standby power units	15-6		
Starting engine	15-6		
Stopping engine.....	15-11		
Storage			
Guidelines	55-1		

